

* ALSO SUPPLIED IN 4204 DIFFERENTIAL CASE ASSEMBLY

1963 / REAR AXLE (DAPCO NO-SPIN DIFFERENTIAL) (FORD - 8 CYLINDER 427 SPECIAL)

REAR AXLE (6 3/4", 7" & 7 1/4" RING GEAR)-TYPICAL INTEGRAL CARRIER
1960/ FALCON

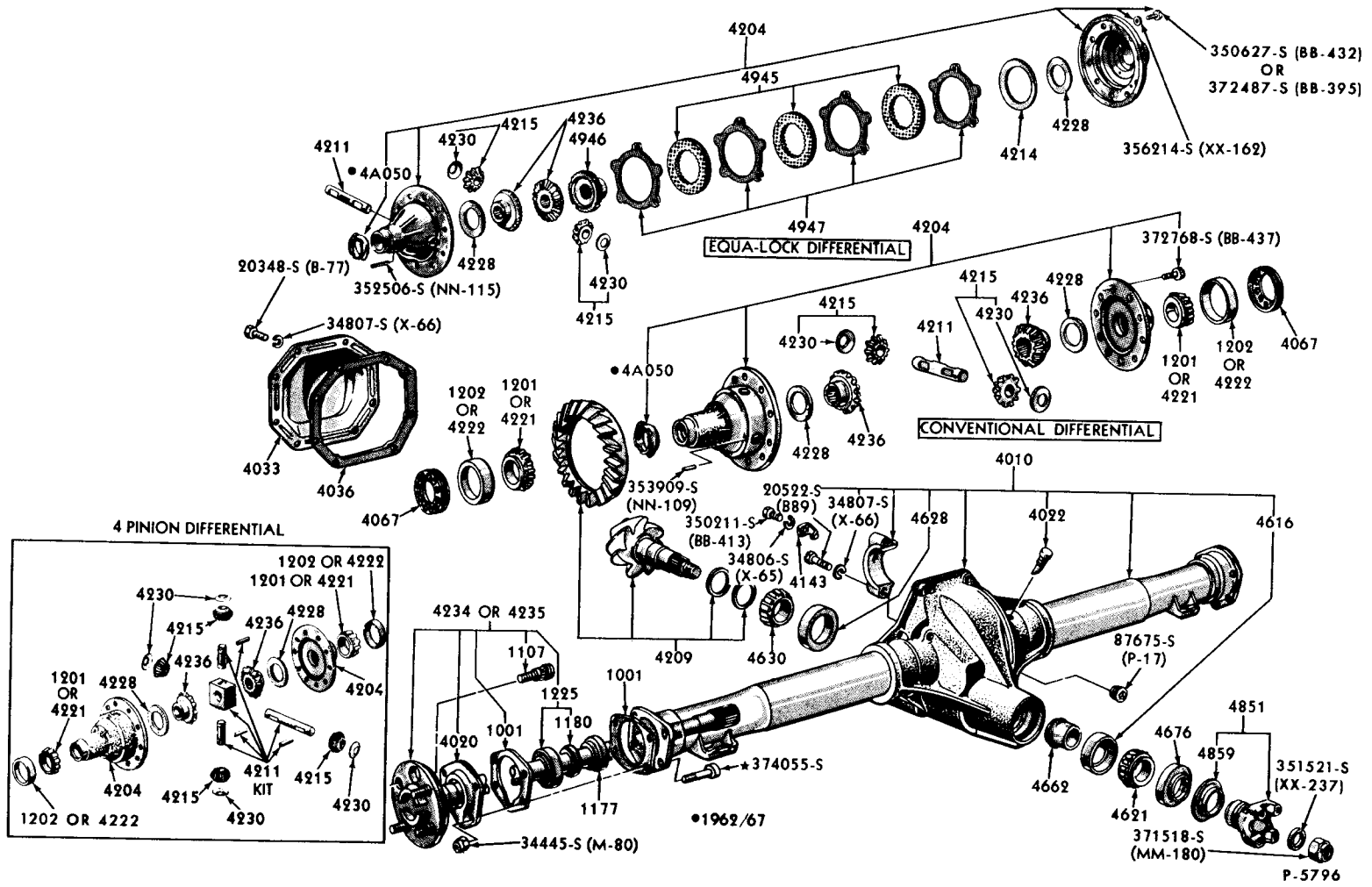

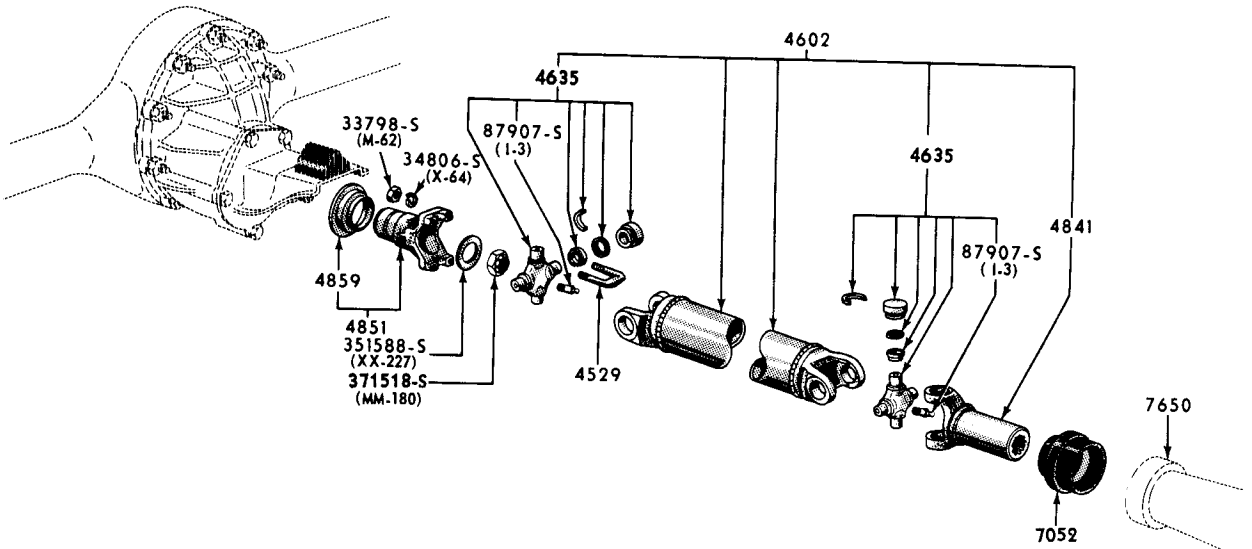

P-2995

1960/ DRIVE SHAFT & RELATED PARTS (FORD, FAIRLANE)- TYPICAL
1960/ DRIVE SHAFT & RELATED PARTS (THUNDERBIRD TWO-DOOR)- TYPICAL

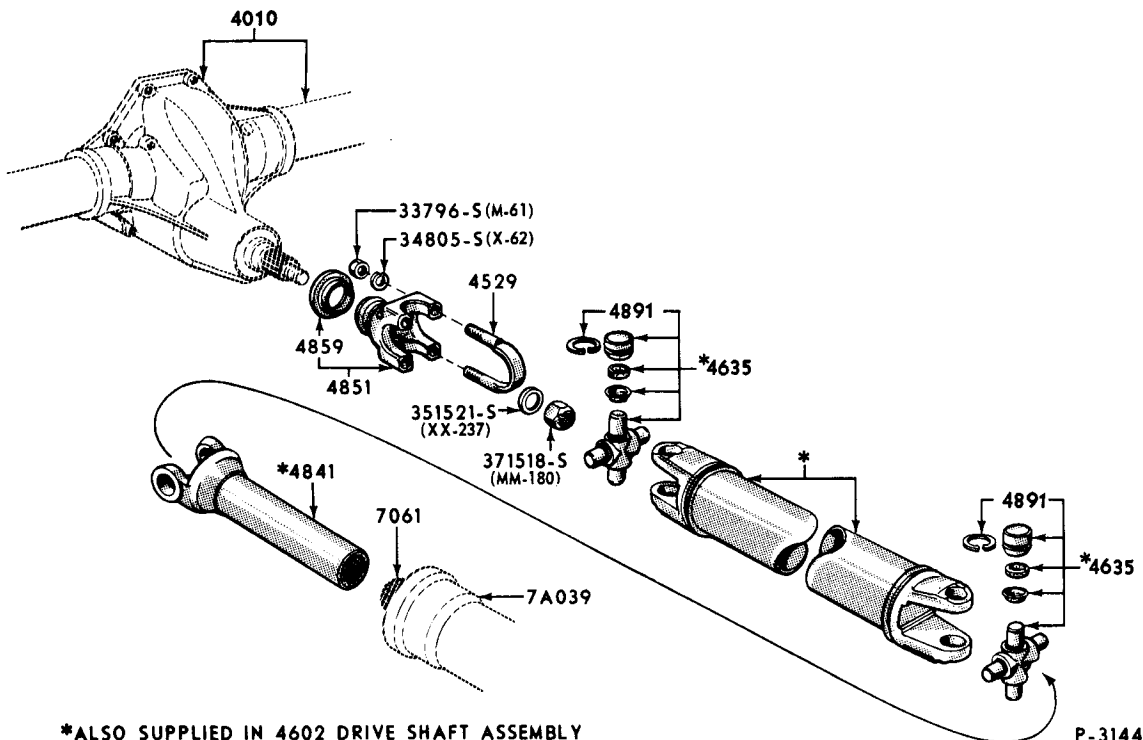

*ALSO SUPPLIED IN 4602 DRIVE SHAFT ASSEMBLY

P-3144

1960/ DRIVE SHAFT & RELATED PARTS (FALCON)- TYPICAL