

Pivot Arms for Squarebird Booster Offset Bracket ver. 1a -06

Drn. by: H. Prout

Rev. date: 2012 03 04 -06

Scale: Full Size

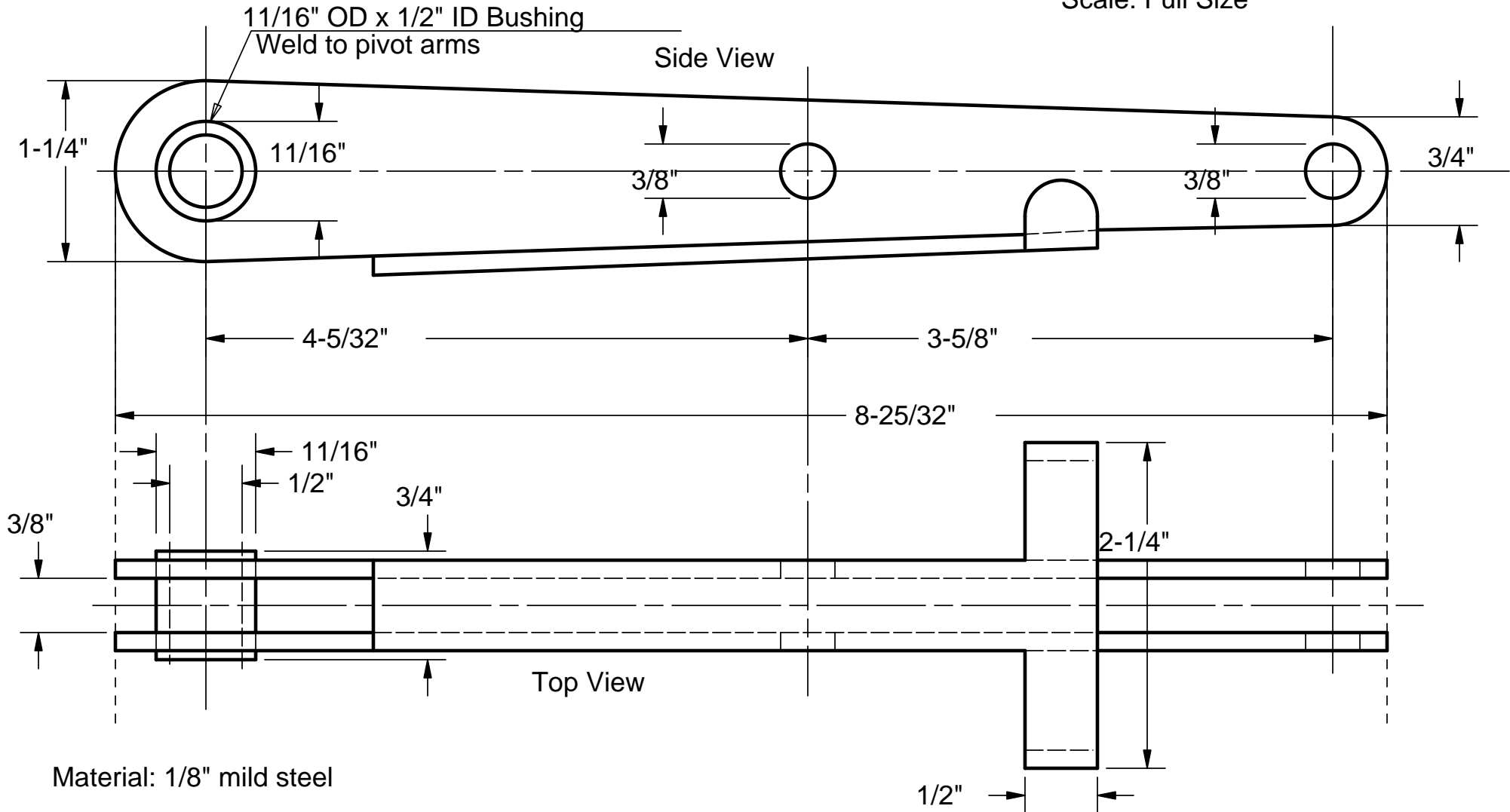

Material: $1/8''$ mild steel

Two arm pieces required per assembly

One brace/centering arm required per assembly - weld to pivot arms