

INDEX

SECTIONS 30 THRU 46 - FRONT SUSPENSION, STEERING SYSTEM AND REAR AXLE

PART NAME	GROUP NUMBER	PART NAME	GROUP NUMBER
Actuator (power steering valve)	3812	Clamp (ball return guide)	3544
Adaptor & gusset ass'y. (front suspension lower arm)	3A031-2	Clamp (column to instrument panel)	3668
Adaptor ass'y. (p/s oil reservoir inlet tube)	3B726	Clamp (power steering cylinder piston rod boot)	3C755
Adaptor (power steering pump to reservoir)	3670	Clamp (power steering hose)	3C750
Adjuster ass'y. (steering worm thrust bearing)	3A670		3A762
Adjuster (p/s control valve sleeve lock nut)	3821	Clamp (power steering hydraulic control)	3A728
Adjuster (p/s control valve spool)	3B700	Clamp (steering column)	3506
Arm & bushing ass'y. (steering idler)	3A734	Clamp (steering column shroud)	3D670
Arm ass'y. (lower)	3078-9	Clamp (steering spindle)	3287
Arm (idler)	3355	Cover ass'y. (steering idler arm bearing)	3B042
Arm (sector shaft)	3590	Cover (column opening or neutral switch)	3A673
Arm (upper)	3082-3	Cover (moveable steering column opening)	3C525
Ball & cage (worm thrust bearing)	3571		3B674
Bearing ass'y. (p/s control valve sleeve)	3B673	Cover (power steering linkage dust)	3A729
Bearing (column release cam)	3D581	Cover (power steering oil reservoir)	3A582
Bearing (column)-upper	3517	Cover (power steering pump housing)	3A698
Bearing (moveable steering column to track lower bracket)	3C728	Cover (sector shaft housing)	3580
Bearing (sector shaft)	3576	Cover (steering wheel hub)-lower	3491
Bearing (steering column pilot)	3B648	Cup (worm bearing)	3552-3
Body ass'y. (power steering oil reservoir)	3A699	Cylinder ass'y. (power steering)	3A540
Bolt (lower arm mounting)	3057	Element (power steering oil reservoir filter)	3-3538
Bolt (power steering control valve spool)	3-3698	Emblem (horn button)	3524
Bolt (p/s oil filter element support or cover retaining)	3601	Emblem (steering wheel hub)	3649
Bolt (steering column tube flange to tube)	3641	End (spindle rod)	3289
Boot (p/s cylinder)	3C528	Extension (column tube flange)	3790
Brace (moveable steering column track)	3C557	Flange & insulator ass'y. (flexible joint)-steering	3A525
Brace (moveable steering column track inner)	3C762	Flange & pin (column tube)	3511
Bracket ass'y. (moveable strg. column to track)	3B659	Gasket (power steering control valve body)	3A740
Bracket (bumper)	3382-3	Gasket (power steering oil reservoir cover)	3A642
Bracket (column to instrument panel)	3676-8	Gasket (power steering oil reservoir filler cap)	3C675
Bracket (front radius arm)	3B095	Gasket (power steering oil reservoir filter)	3C719
Bracket (front suspension lower arm mtg.)	3A031-2	Gasket (sector housing or housing cover)	3581
Bracket (frt. suspension lwr. arm mtg.) rear	3A134	Gear (less arm, wheel & tube)	3504
Bracket (frt. suspension lower arm strut mtg.)	3416	Grommet (column to dash)	3512
	3486-7	Guide ass'y. (front suspension spring)	3A197
Bracket (idler arm mounting)	3350-1	Guide (ball return)	3523
Bracket (moveable steering column locking actuator)	3B649	Guide (moveable column opening cover)	3C571
Bracket (moveable steering column track stop)	3B666	Hose ass'y. (p/s control valve to cylinder)	3A714
Bracket (moveable strg. column track support)	3C574	Hose (column release supply)	3D585
Bracket (power steering cylinder mounting)	3A652	Hose (power steering pressure line)	3A719
Bracket (power steering hose insulator)	3A611	Hose (power steering reservoir to pump)	3691
Bracket (power steering hose spring)	7542	Hose (power steering return line)	3A005
Bracket (power steering pump adjusting)	3A732		3A713
Bracket (power steering pump support)	3562	Housing ass'y. (front suspension mtg.) on body	3443-4
Bracket (steering column & instrument panel cover pivot)	3D626	Housing ass'y. (steering gear)	3548
Bracket (steering column lower track support strut)	3C570	Housing (power steering pump)	3A643
Bumper (front suspension)	3019-20	Insert (steering wheel hub cap retainer)	3660
Bumper (moveable steering column locking lever)	3B151	Insert (steering wheel trim)	3C680
Bumper (moveable strg. column track stop bracket)	3C726	Insulator ass'y. (steering gear)	3C716
Bushing ass'y. (front suspension upper arm) inner	3062	Insulator (horn button)	3672
Bushing (column)-upper	3517	Insulator (horn ring)	3673
Bushing (idler arm)	3350-8	Insulator (moveable steering column pivot)	3B653
Bushing (lower arm mounting bolt)	3069	Insulator (power steering control valve linkage stop)	3C562
Bushing (moveable strg. column locking lever pivot)	3B642	Insulator (power steering hose)	3A609
Bushing (moveable steering column pivot)	3B654	Insulator (power steering pump)	3-3640
Bushing (p/s control valve spool)	3A518-9	Insulator (steering column lower flange)	3B564
Bushing (steering column opening cover pivot)	3D502		3674
Bushing (steering shaft)	3C773	Joint ass'y. (frt. suspension lower arm ball) L. H.	3A106
Bushing (upper arm inner shaft)	3068	Joint ass'y. (front suspension upper arm ball)	3049
Button (moveable steering column to track)	3B644	Joint ass'y. (front suspension upper arm ball) L. H.	3A227
Cap ass'y. (steering wheel hub)	3623	Joint ass'y. (lower arm ball)	3395
Cap (P/S control valve spool adjuster)	3708	Joint ass'y. (upper arm ball)	3263
Cap (P/S control valve spool centering spring)	3C705	Keys (ignition & door)	3685
	3-3705	Kit (drag link adjusting sleeve)	3310
Cap (power steering cylinder)	3A745	Kit (drag link ball stud repair)	3A533
Cap (power steering oil reservoir filler)	3A006	Kit (exhaust air supply)-P/S adapter	3A635
		Kit (frt. suspension lwr. arm strut bushing & washer)	3A187
		Kit (front suspension lower ball joint dust seal repair)	3B035

INDEX

SECTIONS 30 THRU 46 - FRONT SUSPENSION, STEERING SYSTEM AND REAR AXLE - continued

PART NAME	GROUP NUMBER	PART NAME	GROUP NUMBER
Kit (idler arm & bushings)	3352	Ring (power steering pump valve fitting)	3-3618
Kit (idler arm mounting bracket)	3350	Ring (power steering reservoir orifice)	3-3547
Kit (lower shaft or control arm mounting)	3048	Rod (arm to idler arm)	3304-05
Kit (lower spindle support)	3050	Rod (moveable steering column locking)	3B123
Kit (power steering control valve ball stud repair)	3A533	Rod or End (spindle connecting)	3A130-1
Kit (power steering control valve centering spring)	3A675	Rod (power steering piston)	3A545
Kit (power steering control valve repair)	3A650	Screw (sector shaft adjusting)	3577
Kit (P/S control valve spool centering spring cap)	3C705	Seal (front suspension arm ball joint dust)	3A105
Kit (p/s cylinder end mounting bushing)	3C589	Seal (power steering control valve spool adjuster)	3B699
Kit (power steering cylinder seal)	3A764	Seal (power steering control valve spool spring cap)	3C706
Kit (power steering piston boot & insulator)	3C651	Seal (power steering cylinder stud)	3C636
Kit (power steering piston rod end bushing)	3C590	Seal (power steering pump rotor shaft oil)	3B592
Kit (power steering pump impeller repair)	3A711	Seal (shaft oil)	3738
Kit (power steering pump seal & gasket)	3B584	Seal (steering & front suspension)	3332
Kit (P/S sleeve, shaft & torsion bar ass'y.)	3B671	Seal (steering idler arm)	3359
Kit (P/S valve spool retaining ring)	3757	Seal (weather)	3513
Kit (seal & gasket) integral p/s gear	3C538	Seal & bushing (frt. susp. upper arm spring)	3388
Kit (sector shaft adjusting shim)	3A657	Seal (power steering filter element spring)	3B754
Kit (steering gear ball return guide & clamp)	3523	Shaft & bearing ass'y. (moveable steering column)-flexible	3558
Kit (torsion bar ass'y. & sleeve bearing)	3B669	Shaft & flange ass'y. (steering)	3460
Kit (upper shaft)	3047	Shaft & flange (steering)	3524
Kit (upper spindle support)	3049	Shaft & torsion bar (p/s gear input)	3B669
Kit (worm ball)	3647	Shaft (front suspension lower arm) inner	3057
Lever ass'y. (moveable steering column locking)	3B661	Shaft (power steering pump rotor)	3B559
Link (power steering sector shaft arm to spindle connecting rod)	3B163	Shaft (steering gear sector)	3575
Locator (moveable column track)	3C734	Shaft (upper arm)-inner	3056
Lock cylinder & keys (glove compartment, etc.)	3689	Shim (lower arm front mounting bolt to frame)	3054
Moulding (horn blowing ring spoke)	3602	Shim (upper arm mounting)	3043
Nut (front suspension upper arm mounting bolt)	3B023	Shroud (steering column) -L. H.	3533
Nut (worm thrust bearing)	3707	Sleeve (column upper bearing)	3518
Oil seal (sector shaft housing)	3591	Sleeve (drag link adjusting)	3310
Orifice (power steering tube seat)	3A700	Socket (power steering control valve stud)	3A754
Pad (moveable steering column locking bracket)	3D560	Spacer (front suspension lower arm front)	3099
Pin (moveable steering column to track lower bracket)	3C727	Spacer (housing seal)	3C703
Pin (power steering pump rotor shaft)	3-3633	Spacer (power steering control valve spool)	3A658
Pin (steering column release cable)	3E683	Spacer (power steering cylinder mounting bracket)	3C626
Pivot ass'y. (moveable steering column)	3B650	Spacer (P/S pump adjusting bracket)	3D600
Plate (horn ring contact)	3630	Spacer (steering column upper bearing spring)	3B703
Plate (moveable steering column locking)	3B658	Spacer (steering shaft coupling)	3C760
Plate (moveable strg. column shroud cover retaining)	3C533	Spindle ass'y.	3102-8
Plate (power steering control valve)	3-3712	Spring (column position)	3D655
Plate (steering column opening cover)	3B633-4	Spring (column upper bearing)	3520
Plug (housing oil filler)	3538	Spring (moveable steering column to track lower brkt.)	3C730
Plug (power steering connecting link ball stud seat)	3B740	Spring (moveable steering column track locking)	3B664
Plug (power steering gear)	3B730	Spring (p/s control valve reaction limiting)	3C563
Plug (power steering reaction control spring)	3A512-3	Spring (power steering filter element retaining)	3B688
Pulley (power steering pump)	3A733	Spring (power steering hose)	3C697
Pump & pulley ass'y. (power steering)	3A696	Spring (power steering lower shaft)	3A594
Pump (power steering)	3A674	Spring (power steering pump flow control valve)	3A570
Pump, reservoir & pulley (power steering)	3A691	Spring (steering column instru. panel opening cover)	3D514
Race (steering worm outer)	3614	Stop (p/s control valve spool travel regulator)	3C560
Rack & worm (steering gear)	3524	Stop (steering arm)	3A706-7
Reinforcement (flexible coupling steering)	3B629	Strut (front suspension lower arm)	3468
Reinforcement (frt. suspension mounting housing spring seat on body)	3A072	Strut (lower track support)	3C575
Reinforcement (power steering reservoir orifice)	3B563	Stud (drag link to selector arm ball)	3311
Reinforcement (steering column support bracket)	3B743	Support ass'y. (steering column)	3B718
Reservoir ass'y. (power steering oil)	3A697	Support (front suspension bumper bracket)	3B170-1
Retainer & bearing ass'y. (steering column)-upper	3839	Support (power steering pump)	3C511
Retainer (horn ring)	3629	Support (p/s reservoir filter element)	3C677
Retainer (moveable strg. column locking lever spring)	3C733	Track ass'y. (moveable steering column)	3C571
Retainer (moveable steering column track bearing)	3D561	Trim (steering column opening cover)	3B760
Retainer (power steering cylinder stud seal)	3D507	Tube ass'y. (p/s control valve to cyl.-rod end)	3A717
Retainer (power steering hose insulator)	3A610	Tube ass'y. (power steering pressure hose to pump)	3836
Retainer (power steering pump relief valve)	3-3627	Tube ass'y. (p/s return line hose to steering gear)	3B721
	3C742	Tube (column)	3509
Retainer (steering column upper bearing)	3B610		3514
Retainer (steering wheel hub cap)	3657	Tube (column release valve)	3E558
Ring (power steering cylinder cap retaining)	3A746	Tube (p/s pressure line to valve)	3494

INDEX

SECTIONS 30 THRU 46 - FRONT SUSPENSION, STEERING SYSTEM AND REAR AXLE - continued

PART NAME	GROUP NUMBER	PART NAME	GROUP NUMBER
Tube (p/s return line hose to control valve)	3A575	Hub (differential gear clutch)	4946
Valve housing & spool (P/S)	3B731	Kit (differential gear & pinion)	4209
Valve (power steering hydraulic control)	3A730	Kit (differential-less driven gear)	4953
Valve (power steering pump)	3A561	Kit (differential pinion shaft)	4211
Washer (front suspension lower arm front shaft)	3B147	Kit (differential shaft pinion)	4215
Washer (power steering pump adjusting bracket)	3-3638	Kit (differential side gear)	4236-7
Washer (steering column socket-thrust)	3C708	Kit (locking differential)	4880
Washer (steering shaft coupling bolt)	3C660	Kit (universal joint)	4635
Wheel ass'y. (steering)	3600	Knuckle & plug ass'y. (universal joint)	4841
Wire & terminal (shaft ground)	3B710	Lock (differential bearing adjusting nut)	4143
Bearing assy. (driving pinion pilot)	4625	Lubricator (differential)	4159
Bolt (differential carrier to rear axle housing)	4347	Nut or shim (differential bearing adjusting)	4067
Bolt (differential gear to case)	4216	"O" ring (driving pinion bearing retainer)	4669
Bracket (driving pinion bearing retainer)	4298	Packing (universal joint)	4706
Bracket (rear axle bumper)	4731	Plate assy. (differential clutch)	4945
Bumper (rear axle)	4730	Plate (differential gear clutch)	4947
Carrier assy. (differential)	4141	Reinforcement assy. (rear axle bumper mounting)	4A182-3
Case ass'y. (differential gear)	4204-5	Retainer & bearing cups assy. (driving pinion brg.)	4614
Cone & roller (differential bearing)	4221	Retainer (driving pinion pilot bearing)	4627
Cone & roller (pinion bearing)	4621	Retainer (rear wheel bearing)-outer	4020
Cone & roller (pinion bearing)-rear	4630	Scoop (differential case oil)	4A050
Cover (housing)	4033	Screw (cover to housing)	4346
Cup (differential bearing)	4222	Seal (pinion oil)	4676
Cup (pinion bearing)	4616	Shaft & bearing ass'y. (rear axle)	4234-5
Cup (pinion bearing)-rear	4628	Shaft (differential pinion)	4211
Deflector (universal joint oil seal dust)	4859	Shim (pinion bearing)	4663
Drive shaft & related parts	4602	Slinger (pinion shaft oil)	4670
Flange ass'y. (universal joint) axle end	4851	Snap ring (U joint spider bearing)	4891
Gasket (carrier or cover)	4035	Spacer (pinion bearing)	4662
Gear (differential side)	4236	Spring (differential clutch)	4214
Hose assy. (rear axle vent)	4A058	Tube (rear axle housing-vent)	4A001
Hose (power brake booster and air compressor)	4090	"U" bolt (universal joint)	4529
Hose (rear axle housing-vent)	4A049	Vent (rear brake line connection)	4022
Housing ass'y.	4010	Washer (differential pinion shaft thrust)	4230
		Washer (differential side gear thrust)	4228

YEAR	MODEL	DESCRIPTION	QTY.	PART NUMBER
3A005 HOSE - POWER STEERING RETURN LINE - Refer to Group 3A719				
3A006 CAP ASSY. - POWER STEERING OIL RESERVOIR FILLER				
60/64	A, B	Dip stick approx. 3" long	1	C1AA 3A006-A
63/64	X (8 cyl.)-without A/C	Pump mounted reservoir	1	
60	S (with A/C)		1	
61/	S (without A/C)		1	
62/	S (Sports Roadster)	Chrome	1	C2SZ 3A006-A
63/	X(Sprint Models 63C & 76B)	Without A/C	1	
63	X(6 cyl.)	Dip stick approx. 1 1/2" long	1	C3DZ 3A006-A
60	S (with A/C)		1	
3019-20 BUMPER ASSY. - FRONT SUSPENSION				
60/63	A	Upper arm-3/8"-24 x 3/4" bolt thread	2	C0AZ 3020-A
60	S		2	
60/63	A	Lower arm-3/8"-24 x 3/4" bolt thread	2	B8A 3019-A
60	S		2	
63/64	A	Upper arm-3/8"-16 x 11/16" bolt thread	2	C3AZ 3020-B
63/64	A	Lower arm-3/8"-16 x 1/2" bolt thread	2	C3AZ 3020-A
61/	S		2	C1SZ 3020-A
60/62	X		2	C0DZ 3020-A
63/	X (6 cyl.)		2	C3DZ 3020-A
63/64	X (8 cyl.)		2	C3DZ 3020-B
60/	B, X	Nut (bumper to underbody)-5/16"-24	2	33798-S7-8(M62)
		Lockwasher-5/16"		34806-S7(X64)
		Nut- (upper arm)-3/8"-24		33800-S8(M63)
		Lockwasher-3/8"		34847-S8(X74)
60/63	A, S	Locknut (lower arm bumper to arm)-3/8"-24	2	34370-S8(M99)
64/	A	Locknut (lower arm bumper to arm)-3/8"-16	2	33799-S7(M52)

YEAR	MODEL	DESCRIPTION	QTY.	PART NUMBER
3B023 NUT - FRONT SUSPENSION UPPER ARM MOUNTING BOLT				
62/64	B	5/8"-18	4	C2OZ 3B023-A
3A031-2 ADAPTOR and GUSSET ASSY. - FRONT SUSPENSION LOWER ARM				
62/64	B	At end of arm	2	C2OZ 3A031-C
62/	B	R. H. - On body	1	C2OZ 3A031-B
		L. H.	1	C2OZ 3A032-A
		Bolt (bracket to body)-7/16"-14 x 1 1/8"	8	20410-S8(B103)
		Lockwasher-7/16"		34808-S8(X67)
60/63	X	R. H.	1	C5DZ 3A031-A
		L. H.	1	C0DB 3A032-B
64/	X	R. H.	1	C5DZ 3A031-A
		L. H.	1	C5DZ 3A032-A
3B035 KIT - FRONT SUSPENSION LOWER BALL JOINT DUST SEAL REPAIR				
62	X	Consists of - Not replaced 1-C2OA 3A027-D Retainer 3-34781-S 1/washer 1-C2DZ 3A105-B Seal 1-72053-S Cotter pin 3-33798-S Nut 3-376323-S Bolt	1	★C2DZ 3B035-A
3B042 COVER ASSY. - STEERING IDLER ARM BEARING				
63/	X		2	C3DZ 3B042-A
3043 SHIM - FRONT SUSPENSION UPPER ARM MOUNTING				
60/64	A, X	.113"/.123" thick-1.04" wide	AR	C0AA 3043-A
60	S		AR	
60/64	A, X	.027"/.033" thick-1.04" wide	AR	C0AA 3043-B
60	S		AR	
61/64	A	.013"/.017" thick-1.04" wide	AR	C1AA 3043-A
60/64	X		AR	
3047 KIT - FRONT SUSPENSION UPPER SHAFT				
60/64	A	Consists of 1-C0AA 3056-A Shaft 2-379329-S2 Bolt 2-C1AA 3068-A Bushing 2-370367-S100 Seal 2-352596-S7 Nut 2-34784-S7 L/washer 2-87924-S7-8 Fitting	2	C0AZ 3047-A
62/	B	Consists of 2-C5OZ 3B023-B Nut 2-87924-S7-8 Fitting 1-C3OA 3056-B Shaft 2-370367-S100 Ring 2-C70A 3068-A Bushing 2-377261-S8 Bolt 2-376539-S7 Washer	2	C3OZ 3047-B
60	S	Consists of 1-AJ 3056-A Shaft 2-357625-S7-8 L/washer 2-AJ 3068-A Bushing 2-379329-S2 Bolt 2-20431-S8 Bolt 2-AJ 33042-B Washers 2-352596-S7 Nuts 2-34784-S7 Lockwashers	2	B7A 3047-A
61/	S	Consists of 1-C3SA 3056-A Shaft 2-373518-S2 Bolt 2-C2SZ 3068-A Bushing 2-374268-S L/washer 2-55752-S7 Nut 2-374269-S Seal 2-87921-S Fitting	2	C3SZ 3047-A
60	X	Consists of 1-C0DD 3056-A Shaft 2-20411-S8 Bolt 2-C0DD 3068-A Bushing 2-379329-S2 Bolt 2-AJ 33042-B Seal 2-34783-S7 L/washer	2	C0DZ 3047-A
61/	X	Consists of 1-C3DA 3056-A Shaft 2-87924-S7-8 Fitting 2-C70A 3068-A Bushing 2-370367-S100 Ring	2	C3DZ 3047-A
3048 KIT - FRONT SUSPENSION LOWER SHAFT or CONTROL ARM MOUNTING				
60/61	A (with link-less type suspension)	Control arm mounting-consists of	2	C0AZ 3048-A
60	S	1-AJ 3055-A Bolt 1-AJ 33042-B Washer 1-C1AA 3057-B Bolt 1-MG 33042-A Washer 1-C0AA 3069-A Bushing 1-20451-S8 Bolt 1-C1AA 3069-A Bushing 1-34783-S7 Lockwasher 1-55701-S8 Locknut	2	

YEAR	MODEL	DESCRIPTION	QTY.	PART NUMBER
3048 KIT - FRONT SUSPENSION LOWER SHAFT or CONTROL ARM MOUNTING - continued				
61/62	A (with link type suspension)	Control arm mounting - consists of 1-AJ 3055-A Bolt 1-AJ 33042-B Washer 1-C1AA 3057-A Bolt 1-MG 33042-A Washer 1-C0AA 3069-A Bushing 1-20451-S8 Bolt 1-C1AA 3069-A Bushing 1-34783-S7 Lockwasher 1-55701-S8 Locknut	2	C1AZ 3048-A
63/64	A (except 8 cyl. 427)	Lower arm shaft mounting - consists of 1-C1MM 3055-B Bolt 1-C3AZ 3069-C Bushing 1-C3AZ 3057-A Shaft 1-C3AZ 3B147-A Washer 1-C3AZ 3069-A or 2-55701-S8 Nut C3AZ 3069-H Bushing 2-374952-S Washer 1-C3AZ 3069-D or 2-374953-S Washer C3AZ 3069-G Bushing 2-376882-S Washer	2	C3AZ 3048-B
63/	A, A (Taxicab & P/I)-H/D-8 cyl. 427	Control arm mounting - consists of 1-C1MM 3055-B Bolt 2-C4AA 3B172-A Adapter 1-C4AA 3057-A Bolt 1-C4AA 3B173-A Adapter 1-C3AZ 3069-E BUSHING 1-C4AA 3B174-A Adapter 1-C3AZ 3069-F BUSHING 1-55701-S8 Nut 1-MG 33042-A WASHER 1-376882-S Washer	2	C4AZ 3048-A
3049 KIT - FRONT SUSPENSION UPPER SPINDLE SUPPORT				
60/64	A		2	C1AZ 3049-A
60	S		2	
	Consists of 1-C4AA 3623-A Ball joint 1-72035-S7-8 Cotter pin 2-34782-S Lockwasher 2-20389-S8 Bolt 2-33800-S8 Nut			
61/62	S	R. H.	1	C2SZ 3049-A
	Consists of 1-C1SS 3A108-B Seal 1-C1SS 3266-B Stud 1-34033-S8 Nut 1-C1SS 3A111-E Seal 1-C2SA 3A273-A Gasket 1-72035-S Cotter pin 1-C1SS 3A236-A Cover 1-C1SS 3394-E Bearing 1-87921-S8 Fitting 1-C2SA 3264-B Socket 6-33798-S Nut 3-304721-S Bolt			
61/62	S	L. H.	1	C2SZ 3049-B
	Consists of 1-C2SA 3A102-B Socket 1-C1SS 3266-B Stud 1-34033-S8 Nut 1-C1SS 3A108-B Seal 1-C2SA 3A273-A Gasket 1-72035-S Cotter pin 1-C1SS 3A111-E Seal 1-C1SS 3394-E Bearing 1-87921-S8 Fitting 1-C1SS 3A236-A Cover 6-33798-S Nut 3-304721-S Bolt			
60/62	X		2	C1DZ 3049-A
	Consists of 1-C1DD 3A105-A Seal 3-33798-S8 Nut 1-72025-S Cotter pin 1-C1DD 3263-A Ball joint 3-34781-S7 Lockwasher 1-373132-S8 Nut 3-20367-S8 Bolt			
3049 JOINT ASSY. - FRONT SUSPENSION UPPER ARM BALL				
62/	B	R. H.	1	C2OZ 3049-C
		L. H.	1	C2OZ 3049-D
63/	S	Includes 72035-S Cotter pin	2	C3SZ 3049-A
63/	X	Includes 72035-S Cotter pin	2	C7OZ 3049-A
62/	B	Bolt (joint to arm)-5/16"-24 x 1 1/32" serrated Nut-5/16"-24	8	376323-S(BB390R) 33798-S8(M62)
		Lockwasher-5/16"		34806-S7(X64)
3050 KIT - FRONT SUSPENSION LOWER SPINDLE SUPPORT				
60/64	A		2	C1AZ 3050-B
60	S		2	
	Consists of 1-C4AA 3395-A Ball joint 2-33800-S8 Nut 2-34782-S Lockwasher 2-20389-S8 Bolt 1-72035-S Cotter pin			
61/	S	R. H.	1	C3SZ 3050-A
	Consists of 1-C3SA 3A027-A Retainer 1-34033-S8 Nut 3-34806-S7 Lockwasher 1-C3SA 3A105-B Seal 1-72035-S7-8 Cotter pin 3-378064-S8 Screw 1-C4SA 3395-A Ball joint 3-351089-S8 Nut			
61/	S	L. H.	1	C3SZ 3050-B
	Consists of 1-C3SA 3A027-A Retainer 1-34033-S8 Nut 3-351089-S8 Nut 1-C3SA 3A105-B Seal 3-34806-S7 Lockwasher 3-378064-S8 Screw 1-C4SA 3A106-A Ball joint 1-72035-S7-8 Cotter pin			

YEAR	MODEL	DESCRIPTION	QTY.	PART NUMBER
3054 SHIM - FRONT SUSPENSION LOWER ARM FRONT MOUNTING BOLT TO FRAME				
60/62	A	.060" thick	AR	MK 3054-A
63/	A(H/D suspension)		AR	
63/	A	.113"/.123" thick-1 35/64" I.D. -2 21/64" O.D.	AR	C3AZ 3054-A
63/	A	.027"/.033" thick-1 35/64" I.D. -2 21/64" O.D.	AR	C3AZ 3054-B
61/	S	3 3/4" x 2 1/2"-.113"/.127" thick	AR	C1SS 3054-C
61/	S	3 3/4" x 2 1/2"-.023"/.027" thick	AR	C1SS 3054-D
60	S	1/16" thick	AR	B5A 3054-A
60/	X(54, 58, 62, 64, 76)	1/16" thick	2	LA 3054-A
3055 BOLT - FRONT SUSPENSION LOWER ARM MOUNTING - Supplied in 3048 Kits				
3056 SHAFT - FRONT SUSPENSION UPPER ARM - INNER				
		OVERALL LENGTH	HOLE CENTER	THREAD
60/64	A	10 5/8"	5 1/2"	3/4"-11
62/63	B	9 1/4"	4 1/4"	3/4"-11
64/	B	9 3/8"	4 1/4"	3/4"-11
63/	X	8 23/32"	3 3/4"	3/4"-8
60	S	10 1/2"	6"	ends tapped
61	S	10 11/32"	5 1/2"	7/8"-8
62	S	10 19/32"	5 1/2"	7/8"-8
63/	S	10 19/32"	5 1/2"	7/8"-8
60	X	8 7/16"	3 3/4"	ends tapped
61/63	X	8 19/32"	3 3/4"	3/4"-11
60/	S, X	Bolt (shaft to upper arm)-7/16"-20 x 1 1/8"	4	20411-S7(B184)
		Lockwasher-7/16"	2	34808-S8(X67)
60/	A, B, X	Seal (shaft)-.736" I.D.	4	370367-S100(KK49)
63/	S	Seal (shaft)-.859" I.D. -.189" wide-Rubber	4	374269-S(KK49B)
3057 SHAFT - FRONT SUSPENSION LOWER ARM - INNER - Supplied in 3048 Kits				
3062 BUSHING ASSY. - FRONT SUSPENSION UPPER ARM - INNER - Refer to Group 3068				
3068 BUSHING - FRONT SUSPENSION UPPER ARM INNER SHAFT - Supplied in 3047 Kit if not listed below				
62/	A (P/I & Taxicab only)	Heavy duty suspension	4	C2AZ 3068-A
62	B (P/I & Taxicab only)	Heavy duty suspension	4	
61/62	S	No lube fitting hole	4	C1SS 3062-B
62/	S	1/4"-28 lube fitting hole	4	C2SZ 3068-A
3069 BUSHING - FRONT SUSPENSION LOWER ARM MOUNTING BOLT				
60	A	Front-5/8" I.D.	2	C0AA 3069-B
61/62	A	Front-5/8" I.D.	2	C1AA 3069-A
63/64	A	Front-3/4" I.D. x 2 3/4" long	2	C3AZ 3069-H
63/64	A	Rear-7/8" I.D. -2 9/16" long	2	C3AZ 3069-G
63/	A	Shaft mounting-4 19/64" long	2	C3AZ 3069-C
63/64	A(P/I & Taxicab)	Front-7/8" I.D.	2	C3AZ 3069-E
63/64	A(P/I & Taxicab)	Rear-5/8" I.D.	2	C3AZ 3069-F
62/	B	1/2" I.D. -2 13/16" long	2	C2OZ 3069-B
60	S	7/8" I.D.	4	C0AA 3069-A
60/62	A	Rear	2	
61/	S	1/2" I.D.	2	C1SS 3069-C
63/	A	Seal (bushing)-15/16" I.D. -3/16" thick-rubber	2	376883-S(KK49A)
3A072 REINFORCEMENT - FRONT SUSPENSION MOUNTING HOUSING SPRING SEAT				
60/	X	On body	2	C4DZ 3A072-B
3078-9 ARM ASSY. - FRONT SUSPENSION LOWER				
60/62	A	R. H. -includes joint	1	C2AZ 3078-B
60	S	L. H. -includes joint	1	C2AZ 3079-B
63/64	A(except P/I & Taxicab)	R. H. -includes joint	1	C3AZ 3078-D
		L. H. -includes joint	1	C3AZ 3079-D
63/64	A(P/I & Taxicab)	H/D-R. H. -includes joint	1	C3AZ 3078-E
		H/D-L. H. -includes joint	1	C3AZ 3079-E
62/	B	R. H. -includes joint	1	C4OZ 3078-A
		L. H. -includes joint	1	C4OZ 3079-A
61/64	S	R. H. -includes joint	1	C3SZ 3078-B
		L. H. -includes joint	1	C3SZ 3079-B

* Supplied in 3047 kits

YEAR	MODEL	DESCRIPTION	QTY.	PART NUMBER
3078-9 ARM ASSY. - FRONT SUSPENSION LOWER - continued				
60/62	X	"Before 10/15/61" Includes joint	2	C1DZ 3078-B
62/	X	"From 10/15/61" Includes joint	2	C4DZ 3078-A
60/	S	Tee nut-5/16"-24	4	*34552-S
60/	S	Bolt (arm to underbody)-7/16"-20 x 1 1/2"	4	20471-S7(B188)
62/	B	Bolt (arm to bracket)-1/2"-13 x 3 61/64"	2	C1VE 6345-A
61/	S	Screw (arm to reinforcement)-5/16"-24 x 1"	6	378064-S7-8 (BB638D)
3082-3 ARM ASSY. - FRONT SUSPENSION - UPPER				
60/64	A	R. H.	1	C3AZ 3082-A
		L. H.	1	C3AZ 3083-A
62/	B	R. H. -includes shaft & joint	1	C3OZ 3082-A
		L. H.	1	C3OZ 3083-A
63/	X	Includes shaft & joint	2	C4DZ 3082-B
60	S	R. H.	1	B8S 3082-A
		L. H.	1	B8S 3083-A
61/62	S	R. H. -includes joint	1	C2SZ 3082-A
		L. H.	1	C2SZ 3083-A
63/	S	R. H. -includes joint	1	C3SZ 3082-B
		L. H.	1	C3SZ 3083-A
60/62	X	Includes shaft & joint	2	C1DZ 3082-B
60/64	A	Bolt (arm to frame)-1/2"-20 x 2 25/64"-serrated	4	379329-S(BB390Y)
60	S		4	
60/	X	Bolt (arm to underbody)	4	
		Nut-1/2"-20		33846-S8(M69)
		Lockwasher-1/2"		34809-S8(X68)
61/	S	Bolt (arm to underbody)-1/2"-13 x 2 1/4"serrated	4	373518-S2(BB390E)
62/64	B	Bolt (arm to underbody)-5/8"-18 x 2 31/64"	4	376537-S7-8 (BB259N)
62/	B (P/I & Taxicab)	Fitting-lubricator (arm) - 1/4"-28-90°	4	87924-S8(I-9)
61/	S	Fitting-lubricator (spring pivot bushing)	4	374281-S8(II-207)
		Nut-1/2"-13		380952-S2(MM11B)
3099 SPACER - FRONT SUSPENSION LOWER ARM FRONT				
61/ 62	A (use with C1MM 5019-B crossmember)	With link type suspension-5/8" I.D. -1 13/32" O. D. - 5/8" long	2	C1AA 3099-A
61/ 62	A (use with C1MM 5019-B crossmember)	With linkless type suspension	4	
63	A		4	
3102-6 SPINDLE ASSY.				
60/64	A Special (8 cylinder 352, 390, 406, 427)- For Special Duty Performance	R. H.	1	C0AZ 3102-A
		L. H.	1	C0AZ 3103-A
60/64	A	R. H.	1	C2AZ 3105-A
		L. H.	1	C2AZ 3106-A
62/63	B	R. H.	1	C3OZ 3105-A
		L. H.	1	C3OZ 3106-A
64/	B	R. H.	1	C4OZ 3105-A
		L. H.	1	C4OZ 3106-A
60	S	R. H.	1	C0SS 3105-A
		L. H.	1	C0SS 3106-A
61/62	S	R. H.	1	C2SZ 3105-A
		L. H.	1	C2SZ 3106-A
63/64	S	R. H.	1	C3SZ 3105-B
		L. H.	1	C3SZ 3106-B
60/62	X	"Before 10/15/61" R. H.	1	C1DD 3107-A
		"Before 10/15/61" L. H.	1	C1DD 3108-A
62	X	"From 10/15/61" R. H.	1	C2DZ 3105-B
		"From 10/15/61" L. H.	1	C2DZ 3106-B
63/	X (6 cyl.)	R. H. -includes 1-374502-S nut	1	C3DZ 3105-A
		L. H. -includes 1-374502-S nut	1	C3DZ 3106-A
63/64	X (8 cyl.)	R. H. -includes 1-374504-S nut	1	C3DZ 3105-B
		L. H. -includes 1-374504-S nut	1	C3DZ 3106-B
60/61	A	Nut-castle (spindle)-3/4"-16	2	354573-S(MM64)
60	S		2	
		Cotter pin-5/32" x 1 1/4"		72054-S(N61)

YEAR	MODEL	DESCRIPTION	QTY.	PART NUMBER						
3102-6 SPINDLE ASSY. - continued										
61/	S	Nut (spindle)-3/4"-16	2	374504-S(MM38C)						
62/	A, B		2							
63/	X (8 cyl.)-H/D		2							
60/	A	Nut-castle (upper ball joint to spindle)-9/16"-18	2	34033-S18(M11)						
60	S		2							
61/	B, S, X	Upper & lower	4							
62/	A, B, X	Nut retainer (lock)-3/4" I.D. -8 slots	2	374536-S						
61/	S		2	(MM304A)						
60/	A	Nut-castle (lower ball joint to spindle)-5/8"-18	2	34034-S18(M12)						
60	S		2							
60/61	X	Nut-slotted (spindle)-5/8"-18	2	33987-S18(M17)						
		Cotter pin-5/32" x 1 1/4"		72054-S(N61)						
62/	X	Nut (spindle)-5/8"-18	2	374502-S(MM38A)						
3A105 SEAL ASSY. - FRONT SUSPENSION ARM BALL JOINT DUST										
62/	B	Upper arm	2	C2OZ 3A105-B						
63/	X		2							
62/	B	Lower arm	2	C2OZ 3A105-C						
63/	X		2							
63/	S	Upper Arm	2	C3SZ 3A105-A						
60/62	X	"Before 10/15/61" Upper & lower arm	4	C1DD 3A105-A						
62	X	"From 10/15/61" Upper arm	2							
62	X	"From 10/15/61" Lower arm	2	C2DZ 3A105-B						
62	X	Bolt (seal to arm)-5/16"-24 x 1 1/32"-serrated	6	376323-S(BB390R)						
		Nut-5/16"-24	6	33798-S8(M62)						
		Lockwasher-5/16"	6	34806-S7(X64)						
3A106 JOINT ASSY. - FRONT SUSPENSION LOWER ARM BALL - L.H. - Supplied in 3050 Kit										
3107-8 SPINDLE ASSY. - Refer to Group 3102-6										
3B123 ROD - MOVEABLE STEERING COLUMN LOCKING										
63	A(8 cyl. 260, 289)-with F/M/2		1	C3AZ 3B123-C						
63	A (8 cyl. 352, 390)-with C/M		1	C3AZ 3B123-A						
63	A (8 cyl. 260, 289)-with C/M		1	C3AZ 3B123-D						
63	A(8 cyl.)	Washer-spring (rod to transmission)-5/16"	1	351341-S7(XX326)						
63	A(8 cyl.)-with F/M/2	Washer-flat (rod to transmission)-25/64"	3	356403-S8(XX126)						
63	A(8 cyl.)-with C/M	Washer-flat (rod to transmission)-3/8"	3	372285-S(XX165)						
3A130-1 ROD or END - SPINDLE CONNECTING										
YEAR	MODEL & DESCRIPTION	MANUAL STEERING				POWER STEERING				PART NUMBER
		RIGHT HAND		LEFT HAND		RIGHT HAND		LEFT HAND		
		END	ROD	ROD	END	END	ROD	ROD	END	
- A -										
60	A	1		1	1			1		C0AZ 3A131-A
			1	1			1	1		C0AA 3280-A
61							1		1	C1AZ 3A130-B
61/62	A		1	1						C1AA 3280-B
							1	1		C2AA 3280-A
62/64	A	1			1				1	C3AZ 3A130-A
			1	1						C3AZ 3280-A
							1	1		C3AZ 3280-B
60/	A (Special duty performance)	1			1				1	C1AA 3289-D
			1	1			1	1		C0AA 3280-C
- B -										
62/	B	1			1					C3OZ 3A130-A
			1	1						C3OZ 3280-A
							1			C3OZ 3A130-B
							1	1		C3OZ 3280-B
									1	C3OZ 3A131-A

3A130-1 ROD or END - SPINDLE CONNECTING - continued

YEAR	MODEL & DESCRIPTION	MANUAL STEERING				POWER STEERING				PART NUMBER
		RIGHT HAND		LEFT HAND		RIGHT HAND		LEFT HAND		
		END	ROD	ROD	END	END	ROD	ROD	END	
- S -										
60	S	1			1	1			1	B6SZ 3A130-A
			1				1			B9AA 3280-A
				1				1		B9AA 3281-A
61/62	S					1				C2SZ 3A130-A
							1	1		C2SZ 3280-A
									1	C2SZ 3A131-A
63/64	S					1				C3SZ 3A130-A
							1	1		C3SZ 3280-A
									1	C3SZ 3A131-A

- X -										
60/	X-6 cyl.	1			1					C3DZ 3A130-K
			1	1						C3DZ 3A130-L
63	X-8 cyl.				1				1	C3DZ 3A130-J
63/64	X-8 cyl.	1				1				C3DZ 3A130-G
			1	1			1			C3DZ 3A130-H
								1		C3DZ 3A131-F
64	X-8 cyl.				1					C3DZ 3A130-G
									1	C3DZ 3A130-J
64/	X-6 cyl.					1				C4DZ 3A130-C
							1			C4DZ 3A130-D
								1		C4DZ 3A131-C
									1	C4DZ 3A131-D

YEAR	MODEL	DESCRIPTION	QTY.	PART NUMBER
60/	A, S	Nut-castle-1/2"-20	2	351059-S(MM66)
		Cotter pin-1/8" x 1"		72035-S7-8(N51)
60/	A, S	Fitting-lubricator-1/4"-28-90°	2	87924-S8(I-9)
60/	X	Nut-castle-3/8"-24	2	*34030-S8
		Cotter pin-3/32 x 3/4"		72016-S8(N44)

3A134 BRACKET ASSY. - FRONT SUSPENSION LOWER ARM MOUNTING - REAR

61/	S		2	C1SZ 3A134-A
61/	S	Bolt (bracket to underbody)-5/8"-11 x 2 9/16"-serrated	2	376270-S7-8 (BB390P)
		Nut-5/8"-11		356085-S8(MM14)
61/63	S	Bolt (bracket to arm)-1/2"-13 x 3 7/8"	2	373522-S7-8 (BB199B)
64/	S	Bolt (bracket to arm)-1/2"-13 x 3 61/64"	2	C1VE 6345-A
		Nut-1/2"-13		33845-S8(M57)

3B147 WASHER - FRONT SUSPENSION LOWER ARM FRONT SHAFT

63/	A	3/4" I.D. - 1 5/8" O.D. -serrated	2	C3AZ 3B147-A
-----	---	-----------------------------------	---	--------------

3B151 BUMPER - MOVEABLE STEERING COLUMN LOCKING LEVER

63/	A		1	C3AZ 3B151-A
64/	S		1	

3B163 LINK - POWER STEERING SECTOR SHAFT ARM TO SPINDLE CONNECTING ROD

63/	X (6 & 8 cyl.)		1	C3DZ 3B163-B
63	X(6 & 8 cyl.)	Bolt (link to idler arm rod)-3/8"-24 x 1 7/8"	2	378039-S7-8 (BB222A)
63/	X (6 & 8 cyl.)	Bolt (link to idler arm rod)-3/8"-24 x 2 1/2"	2	351816-S(BB224)
		Locknut-3/8"-24		373173-S8 (MM169C)
		Locknut-3/8"-16		376575-S7-8 (MM173H)

3B170-1 SUPPORT - FRONT SUSPENSION BUMPER BRACKET

63	X (8 cyl.)	R. H.	1	C3DZ 3B170-A
		L. H.	1	C3DZ 3B171-A

YEAR	MODEL	DESCRIPTION	QTY.	PART NUMBER
3A187 KIT - FRONT SUSPENSION LOWER ARM STRUT BUSHING & WASHER - Also refer to Group 3468				
62/	B		2	C2OZ 3A187-A
Consists of				
	1-C4DA 3A140-B Bushing	1-C2OA 3A142-D Washer	1-72035-S7-8	Cotter pin
	1-C2OA 3A141-C Washer	1-34033-S18 Nut	1-C4DA 3A225-B	Bushing
61	S		2	CISZ 3A187-B
Consists of				
	1-C1SS 3A140-E Bushing	1-C1SS 3A142-D Washer	1-33987-S8	Nut
	1-C1SS 3A141-D Washer	1-C1SS 3A225-C Bushing	1-44745-S	Washer
		1-72071-S		Cotter pin
62/	S		2	C2SZ 3A187-A
Consists of				
	1-C2SA 3A183-B Bushing	1-C1VV 3433-B Spacer	1-45301-S8	Nut
	1-C2SA 3A184-B Bushing	2-C1VV 3434-B Washer	1-72071-S	Cotter pin
60	X		2	CODZ 3468-B
Consists of				
	2-C0DD 3470-B Insulator	2-34783-S7 Washer	2-376076-S42	Washer
	1-C0DD 3473-B Spacer	2-55676-S8 Nut	2-373143-S	Nut
		2-378499-S8 Bolt		
61/62	X	Use with 5/8"-18 threaded strut	2	C1DZ 3468-B
Consists of				
	2-C1DD 3470-B Insulator	2-34783-S7 Washer	2-373143-S	Nut
	1-C1DD 3473-B Spacer	2-55676-S8 Nut	2-378499-S8	Bolt
		2-374790-S Washer		
62/63	X	Use with 11/16"-18 threaded strut	2	C2DZ 3A187-A
Consists of				
	2-C2DA 3470-B Insulator	1-C2DA 3473-A Spacer	2-376074-S or	
		2-376076-S Washer	376680-S8	Nut
64/	X		2	C4DZ 3A187-A
Consists of				
	1-C5DA 3A141-A Washer	1-C4DA 3A140-B Bushing	1-34426-S8	Nut
	1-C5DA 3A142-A Washer		1-C4DA 3A225-B	Bushing
3A197 GUIDE ASSY. - FRONT SUSPENSION SPRING				
63/	S		2	C3SZ 3A197-A
3A227 JOINT ASSY. - FRONT SUSPENSION UPPER ARM BALL - L. H. - Supplied in 3049 kit				
3263 JOINT ASSY. - FRONT SUSPENSION UPPER ARM BALL - Supplied in 3049 Kits				
60/	X	Fitting (ball joint lubricator)-1/4"-straight	4	87907-S8(I-3)
60/	A, S	Fitting (lower ball joint lubricator)	2	
60/	A, S	Fitting (upper ball joint lubricator)-1/4"-90°	2	87924-S8(I-9)
60/	X	Bolt (joint to arm)-5/16"-24 x 1"	6	20387-S8(B157)
		Nut-5/16"-24		33798-S8(M62)
		Lockwasher-5/16"		34806-S7(X64)
60/	A	Bolt (joint to arm)-3/8"-24 x 1"	4	20389-S8(B171)
		Nut-3/8"-24		33800-S8(M63)
		Lockwasher-3/8"		34807-S8(X66)
61/	A, B	Plug (joint)-1/4"-28-tapered	1	374714-S7-8
63/	X		2	(PP35A)
63/	S	Nut (joint to arm)-5/8"-18	2	350983-S(MM38B)
63/	X	Screw (joint)-5/16"-24 x 1"	4	378268-S2(BB817)
63/	B		8	
3280-1 ROD ASSY. - SPINDLE CONNECTING - Refer to Group 3A130-1				
3287 CLAMP - STEERING				
60/64	A	Spindle connecting rod end	4	B7A 3287-A
60/61	S		4	
62/	B (except P/S)	Spindle connecting rod end	4	C2OZ 3287-A
62/	B (P/S)		4	C1MM 3287-A
61/62	A (P/S)	"From 12/1/60"	4	
62/64	S		4	
64/	X(6 cyl.)-with P/S		4	
63/	X(8 cyl.)-with P/S		4	

YEAR	MODEL	DESCRIPTION	QTY.	PART NUMBER
3287 CLAMP - STEERING - continued				
60/	X(6 cyl.)-without P/S	Includes 4 each C3DA 3287-A Clamp, 358655-S Bolt & 377703-S Nut	1	C3DZ 3287-A
63/	X(8 cyl.)-without P/S		1	
60/62	X	Bolt (clamp)-5/16"-24 x 1 1/4"	4	20427-S7(B158)
60/	A,B	Bolt (clamp)-5/16"-24 x 1 1/2"	4	*355236-S2
60/61	S		4	
60/	ASpecial(8 cyl. 352, 390, 406, 427)	Bolt (clamp)-3/8"-24 x 1 3/4"	4	*20507-S
62/	S		4	
63/	X		4	
62/	B (with P/S)		4	
61/62	A (P/S)		4	
		Locknut-3/8"-24		34445-S7(M80)
63/	A, B, S, X (with P/S)	Locknut-3/8"-24	AR	372755-S(MM140C)
3289 END - SPINDLE CONNECTING ROD - Refer to Group 3A130-1				
3304-05 ROD ASSY. - STEERING ARM TO IDLER ARM				
- A -				
60	A (without P/S)		1	C0AA 3305-D
60	A (with P/S)		1	C0AZ 3304-A
60/	A Special (8 cvl. 352, 390, 406, 427)- For Special Duty Performance		1	C0AA 3304-D
61/62	A (without P/S)		1	C1AA 3304-F
61/62	A (with P/S)		1	C1AA 3304-G
63/64	A (with P/S)		1	C3AZ 3304-A
63/64	A (without P/S)		1	C3AZ 3304-C
- B -				
62	B (with P/S)		1	C2OZ 3304-B
63/	B (with P/S)		1	C3OZ 3304-A
62/64	B (without P/S) "Before 3/2/64"		1	C3OZ 3304-B
64/	B (without P/S) "From 3/2/64"		1	C4OZ 3304-A
- S -				
60	S (without P/S)		1	B9SS 3305-B
60	S (with P/S)		1	B9SS 3304-A
61/62	S		1	C1SZ 3304-A
63/64	S		1	C3SZ 3304-C
- X -				
60/62	X		1	C0DD 3304-C
63/	X(6 cyl.)-without P/S		1	C3DZ 3304-L
64/	X(6 cyl.)-with P/S		1	C4DZ 3304-B
63/	X(8 cyl.)-without P/S	With 1" sector shaft	1	C3DZ 3304-B
63/64	X(8 cyl.)-without P/S	With 1 1/8" sector shaft	1	C3DZ 3304-J
63/64	X(8 cyl.)-with P/S		1	C3DZ 3304-K
60/	A, S (with Power Steering)	Locknut (rod to P/S cylinder)-1/2"-20	1	34424-S(M84)
60/	A, B, S (with Power Steering)	Pin (rod to hydraulic control valve)-1/8" x 7/8"	1	352146-S(NN99)
60/	A, S	Nut-castle-1/2"-20	2	351059-S(MM66)
63/	B, X(8 cyl.)		2	
		Cotter pin-1/8" x 1"	1	72035-S7-8(N51)
62/63	B	Bolt (rod to P/S control valve)-3/8"-24 x 1 1/2"	1	20469-S8(B174)
62	A		1	
		Nut-3/8"-24		33800-S8(M63)
		Lockwasher-3/8"		34807-S8(X66)
60/	X	Nut-castle (rod to idler arm)-3/8"-24	1	*34030-S8
62	A, B	Plug (rod)-1/4"-28 tapered	1	374714-S7-8
63/	X		2	(PP35A)
		Locknut-3/8"-24		34370-S8(M99)
		Cotter pin-3/32" x 3/4"		72016-S8(N44)
63/	A, X	Bolt (rod to P/S control valve)-3/8"-24 x 1 1/4"	1	20429-S8(B172)
64	B		1	
63/	B	Nut-slotted (arm to spindle connecting rod)- 7/16"-20	2	353583-S(MM55)
63/	B	Nut-slotted (arm to sector shaft arm)	1	
64	B	Locknut (rod to sector shaft arm)-5/16"-24	4	34443-S7-8(M79)

YEAR	MODEL	DESCRIPTION	QTY.	PART NUMBER
3310 SLEEVE - DRAG LINK ADJUSTING				
60/64	A Special (8 cyl. 352, 390, 406, 427)- For Special Duty Performance	Includes turn buckle	2	AG 3310-A
60/64	A(except Special)	11/16"-18 x 4 1/2"	2	C2AA 3310-B
62/	B (with P/S)		2	
63/	X(8 cyl.)		2	
60/	S		2	
62/	B(without P/S)	5/8"-18 x 4 17/64"	2	C2OZ 3310-A
3310 KIT - DRAG LINK ADJUSTING SLEEVE				
60/	X (6 cyl.)	1/2"-20 x 6 1/2" sleeve-Consists of 2-C3DA 3287-A Clamp 2-358655-S Bolt 1-C0DD 3314-B Sleeve 2-377703-S Nut	2	C3DZ 3310-A
3311 STUD - DRAG LINK TO SELECTOR ARM BALL - Supplied in 3A533 Kit				
3332 SEAL - STEERING and FRONT SUSPENSION - Also refer to Group 3C636				
60	A, S	Steering link ball stud	4	8M 3332
60	A, S	Drag link to sector arm ball stud	1	B2A 3332-A
61/64	A	Spindle arm connecting rod end dust	4	C1AA 3332-C
62/	B	Spindle connecting rod end dust to spindle- 1 7/32" high	2	C2OZ 3332-B
62/	B	Spindle connecting rod to idler arm dust- 15/16" high	2	C2OZ 3332-C
62/	B	P/S cylinder stud-13/16" high	1	C2OZ 3332-A
63/	S	Spindle connecting rod end dust-1.9" maximum O. D. -1" high	4	C3SZ 3332-A
63	X (8 cyl.) -with m/s		4	
60/62	X	Spindle arm connecting rod end dust	6	C0DD 3332-A
63	X (except 8 cyl. with m/s)	Spindle connecting rod end dust-1.6" maximum O. D. -1" high	4	C3DZ 3332-A
64/	X		4	
3350 KIT - STEERING IDLER ARM MOUNTING BRACKET				
60/63	X(6 cyl.) "Before 2/8/63"	Consists of 1-C3DZ 3351-A Bracket 1-C3DZ 3352-D Arm 1-33985-S43 Nut 1-72035-S Cotter Pin 1-378583-S Washer	1	C0DZ 3350-B
3350-1 BRACKET - STEERING IDLER ARM MOUNTING				
60	A, S (except P/S)		1	B8A 3351-A
60	A (with P/S)		1	C0AA 3350-C
60/64	A Special (8 cyl. 352, 390, 406, 427) For Special Duty Performance		1	C0AA 3351-A
61/62	A	Includes bushing	1	C1AA 3350-C
63/64	A	Includes bushing	1	C3AZ 3350-A
62/64	B(with or without P/S) "Before 3/2/64"	Includes bushing	1	C2OA 3350-A
64/	B(with P/S) "From 3/2/64"		1	
64/	B(without P/S) "From 3/2/64"	Includes bushing	1	C4OZ 3350-A
60	S (with Power Steering)		1	B8S 3351-A
61/62	S "Before 3/15/62"	With 5/8" stud	1	C2SZ 3351-A
62/63	S "From 3/15/62"	Also use 1-C3SZ 3356-A bushing	1	C3SZ 3351-A
64/	S		1	C4SZ 3351-A
63/64	X (6 cyl.) "From 2/8/63"		1	C3DZ 3351-A
63/64	X (8 cyl.)		1	C3DZ 3351-B
61/	A (with P/S)	Bolt (bracket to frame)-3/8"-24 x 4 1/4"-shoulder	1	373835-S(BB496C)
62/64	B	Bolt (bracket to underbody)-3/8"-24 x 3 1/2"	2	45549-S(B179)
		Nut-3/8"-24		33800-S8(M63)
		Nut-3/8"-16		33799-S7(M52)
		Lockwasher-3/8"		34847-S8(X74)
		Washer-flat-3/8"		352981-S(XX143)
60/	S (with Power Steering)	Bolt (bracket to frame)-3/8"-24 x 1 1/2"	1	20469-S8(B174)
		Nut-3/8"-24		351633-S8(MM119)
60/	A, S (with Power Steering)	Lockwasher-3/8"		357629-S7(XX303)
		Washer-flat-3/8"		353992-S(XX127)
60/	A, S (with Power Steering)	Nut-castle (arm to rod)-1/2"-20	2	34032-S7(M9)
		Washer-flat - 33/64"		351810-S8(XX185)
		Washer-flat-17/32"		356606-S8(XX184)
		Cotter pin - 1/8" x 1"		72035-S7-8(N51)
60/	A (with P/S)	Bolt (bracket to frame)-3/8"-16 x 1 1/2"	2	20468-S8(B85)
		Nut-3/8"-16-rivet type-knurled		372093-S8(MM121)

FORD CAR PARTS

SECTION 30

YEAR	MODEL	DESCRIPTION	QTY.	PART NUMBER
3352 KIT - STEERING IDLER ARM and BUSHINGS				
60	A (without P/S)	Consists of 1-C0AZ 3355-B Arm 2-8M 3359 Seal 2-MB 3356-A Bushing 2-87914-S Fittings	1	C0AZ 3352-A
60	A (with P/S)	Consists of 1-C0AZ 3355-C Arm 2-72035-S7-8 Cotter pin 1-MA 3356-B Bushing 2-351810-S8 Washer 1-MA 3358-A Bushing 2-33983-S8 Nuts	1	C0AZ 3352-B
61/62	A(with M/S)	Consists of 1-C2AA 3355-A Arm 2-72026-S Cotter pin 1-C1AA 3356-A Bushing 2-351059-S8 Nut 1-C3AZ 3358-A Bushing 2-356606-S8 Washer	1	C2AZ 3352-A
61/62	A(with P/S)	Consists of 1-C2AA 3355-B Arm 2-72026-S Cotter pin 1-C1AA 3356-A Bushing 2-351059-S8 Nut 1-C3AZ 3358-A Bushing 2-356606-S8 Washer	1	C2AZ 3352-B
63/64	A(with M/S)	Consists of 1-C3AA 3355-B Arm 2-72026-S Cotter pin 1-C3AZ 3356-A Bushing 2-351059-S8 Nut 1-C3AZ 3358-A Bushing 2-356606-S8 Washer	1	C3AZ 3352-B
63/64	A (with P/S)	Consists of 1-C3AA 3355-A Arm 2-72026-S Cotter pin 1-C3AZ 3356-A Bushing 2-351059-S8 Nut 1-C3AZ 3358-A Bushing 2-356606-S8 Washer	1	C3AZ 3352-A
62/64	B(with M/S)	"Before 3/2/64" Consists of 1-C3OA 3B152-A or 2-72026-S Cotter pin C2OA 3355-C Arm 1-C1AA 3356-A Bushing 2-351059-S8 Nut 1-C3AZ 3358-A Bushing 2-375569-S8 Washer	1	C2OZ 3352-A
64/	B(with M/S)	"From 3/2/64" Consists of 1-C4OA 3355-A Arm 2-72026-S Cotter pin 1-C5ZZ 3356-A Bushing 2-351059-S8 Nut 1-C4OZ 3358-A Bushing 2-375569-S8 Washer	1	C4OZ 3352-A
62/	B (with P/S)	Consists of 1-C3OA 3355-A Arm 2-72026-S Cotter pin 1-C1AA 3356-A Bushing 2-351059-S8 Nut 1-C3AZ 3358-A Bushing 2-375569-S8 Washer	1	C2OZ 3352-B
60	S (with P/S)	Consists of 1-C0AZ 3355-A Arm 1-MA 3356-B Bushing 1-MA 3358-A Bushing 2-72035-S7-8 Cotter pin 2-351810-S8 Washer 2-33983-S8 Nuts	1	B4A 3352-B
60	S(with M/S)	Consists of 1-AN 3355-B Arm 2-8M 3359 Seal 2-MB 3356-A Bushing 2-87918-S8 Fittings	1	B8S 3352-A
60/63	X(6 cyl.-with M/S)	"Before 1/7/63" Consists of 1-C0DZ 3355-A Arm 1-33985-S Nut 1-72035-S7-8 Cotter pin 1-373307-S Washer	1	C0DZ 3352-B
63/64	X(8 cyl.-with M/S)	Includes 1 each 72026-S Cotter pin & 351059-S8 Nut	1	C3DZ 3352-J
63/64	X(8 cyl.)-with P/S	Includes 1 each 72026-S Cotter pin & 351059-S8 Nut	1	C3DZ 3352-K
63/	X(6 cyl.-with M/S)	"From 1/7/63" Includes 1 each 33985-S8 or S43 Nut, 72035-S Cotter pin and 378583-S Washer	1	C3DZ 3352-L
64/	X(6 cyl.)-with P/S	Includes 1 each 72026-S Cotter pin & 351059-S8 Nut	1	C4DZ 3352-B
3355 ARM - STEERING IDLER - Supplied in 3352 kits except as listed below				
60/	A Special (8 cyl. 352, 390, 406, 427)-for special duty performance		1	C0AA 3355-A
61/62	S "Before 3/15/62"	Includes bushing & 375908-S washer	1	C1SS 3A734-C
62/63	S "From 3/15/62"	Includes bushing & 44744-S washer	1	C3SZ 3A734-A
64	S	Includes bushing & 378539-S washer	1	C3SZ 3A734-B
61/62	S "Before 3/15/62"	Washer-flat (arm to bracket)-7/16" x 9/16"	1	375908-S(XX331A)
62/63	S "From 3/15/62"	Washer-flat (to bracket)-5/8"	1	44744-S8(X44)

YEAR	MODEL	DESCRIPTION	QTY.	PART NUMBER
3355 ARM - STEERING IDLER - continued				
63	X (6 cyl.)	Washer-flat (arm to bracket)-1/2"	1	378404-S(XX340E)
63/ 64/	X (8 cyl.) S	Washer-flat (arm to bracket)-5/8" x 3/4"	1	378539-S(XX340H)
63/	X (8 cyl.)	Washer-flat (arm to bracket)-25/32"	1	354448-S(XX239)
63/	X (6 cyl.)	Washer-flat (arm to bracket)-7/16"	1	378583 S(XX340G)
60/63	X	"Before 2/7/63" Bolt (arm to body)-3/8"-24 x 3 1/4"	2	351695-S8(BB226)
63/	X	"From 2/7/63" Bolt (arm to underbody)-3/8"-24 x 3 1/2"	2or3	378405-S (BB226A)
60/	X	Locknut-3/8"-24		34370-S8 (M99)
		Washer-flat-3/8"		44727-S8 (X24)
64/	X	Nut-castle (arm to bracket)-9/16"-18	1	34033-S18(M11)
		Cotter pin-1/8"-1"		72035-S7-8(N51)
64/ 64/	B X	Nut-castle (arm to bracket)-1/2"-20	2	351059-S(MM66)
64/	X (8 cyl.), S	Nut-castle (to bracket)-3/4"-16	1	351125-S(MM62)
60/63	X(6 cyl.)-without P/S	Washer-flat (to bracket)-7/16"	1	373307-S(XX340J)
3356-8 BUSHING - STEERING IDLER ARM				
60	A, S(with m/s)		2	MB 3356-A
60	A, S (with P/S)	Upper	1	MA 3356-B
60	A, S (with P/S)	Lower-1.5" long-.63" I.D.	1	MA 3358-A
60/	A, S	Fitting (bushing lubricator)-85°	2	358032-S8(II-205)
60/64	A Special (8 cyl. 352, 390, 406, 427)- for special duty performance		2	LF 3357-A
61/64	A	Lower-1 3/4" long-5/8" I.D. -1 9/32" O.D.	1	C3AZ 3358-A
62/64	B(with or without P/S)	"Before 3/2/64"	1	
64/	B(with P/S)	"From 3/2/64"	1	
61/64	A	Upper-2 7/16" long-5/8" I.D. -1 9/32" O.D.	1	C3AZ 3356-A
62/64	B(with or without P/S)	"Before 3/2/64"	1	
64	B(with P/S)	"From 3/2/64"	1	
61/62	S	"From 4/4/61 to 3/15/62"	1	
64/	B(without P/S)	"From 3/2/64"	1	
64/	B(without P/S)	"From 3/2/64"	1	C4OZ 3358-A
64/	X(6 cyl.)-without P/S	"From 2/3/64"	1	C5ZZ 3356-A
62/63	S	"From 3/15/62"	1	
60/63	X	"Before 1/7/63"	1	C3SZ 3356-A
61	S	"Before 4/4/61"	1	C0DD 3356-A
63/64	X(6 cyl.)-with or without P/S	Upper-.630" I.D. -1.60" O.D.	1	C3DZ 3356-A
		"From 1/7/63 to 2/3/64"		
64/	X(6 cyl.)-with P/S	"From 2/3/64"	1	
63/	X (8 cyl.)-without P/S	Upper-.884" I.D. -1.442" O.D.	1	C3DZ 3356-C
64/	S		1	
63/	X (8 cyl.)-with P/S	Upper-.884" I.D. -1.670" O.D.	1	C3DZ 3356-D
3359 SEAL - STEERING IDLER ARM				
60	A, S (except Power Steering)		2	8M 3359
3382-3 BRACKET ASSY. - FRONT SUSPENSION BUMPER				
60/	A		2	C0AZ 3382-A
62/	B	R.H.	1	C2OZ 3382-B
		L.H.	1	C2OZ 3383-B
61/	S		2	C1SS 3382-D
60/	X	R.H.	1	C3DZ 3382-B
		L.H.	1	C3DZ 3383-B
60/	X	Screw (bracket attaching) -5/16"-24x1 1/8"	12	353483-S2(BB588)
62/63	B	Screw (bracket to fender apron)	14	
		Locknut-5/16" - 24		34393-S7(M98)
61/	S	Bolt (bracket to underbody)-5/16"-18 x 1"	8	20386-S8(B53)
63	X (6 cyl.)	Washer-flat (bracket to apron & side member)- 5/16"	4	44725-S8(X22)
64	B	Bolt (bracket to apron & side member)- 5/16"-24 x 1"	14	20387-S8(B157)
		Lockwasher-5/16"		34906-S8(X98)

YEAR	MODEL	DESCRIPTION	QTY.	PART NUMBER
3388 SEAT and BUSHING ASSY. - FRONT SUSPENSION UPPER ARM SPRING				
60/62	X		2	C1DD 3388-B
63	X		2	C3DZ 3388-A
64/	X		2	C4DZ 3388-A
60/62	X	Fitting (Lubricator) - 1/4" straight	2	87907-S8(I-3)
63/	X	Locknut (seat to arm)-3/8"-24	4	34370-S8(M99)
63/	X	Plug (seat)-1/4"-28	2	374714-S7-8 (PP35A)
63	X	Ring (bushing retaining)-3/4"	4	372876-S(QQ38A)
3395 JOINT ASSY. - FRONT SUSPENSION LOWER ARM BALL - Supplied in 3050 kits or 3078 arm assy.				
61/	A, B	Plug (joint)-1/4"-28-tapered	1	374714-S7-8 (PP35A)
63/	X		2	
60/	A	Bolt (joint to arm)-3/8"-24 x 1"	4	20389-S8(B171)
62/	B	Bolt (joint to arm)-5/16"-24 x 1"	6	20387-S8(B157)
		Nut-5/16"-24		33798-S8(M62)
		Nut-3/8"-24		33800-S8(M63)
		Lockwasher-5/16"		34806-S7(X64)
		Lockwasher - 3/8"		34807-S8(X66)
61/	S	Fitting (lubricator)-1/4"-28-45°	2	87922-S8(I-7)
3416 BRACKET - FRONT SUSPENSION LOWER ARM STRUT MOUNTING BOLT				
62/	B		2	C2OZ 3416-A
63/	S		2	C4SZ 3416-A
61	S		2	
62/	B	Bolt (bracket to body)-7/16"-14 x 1 1/4"	8	20430-S8(B104)
		Lockwasher-7/16"		34808-S8(X67)
3443-4 HOUSING ASSY. - FRONT SUSPENSION MOUNTING - ON BODY				
63/	S	R. H.	1	C3SZ 3443-B
63/	S	L. H.	1	C6SZ 3444-A
3460 SHAFT & FLANGE ASSY. - STEERING - Refer to 3524 Steering Shaft Group				
3468 STRUT - FRONT SUSPENSION LOWER ARM - Also refer to Group 3A187				
62/	B (except H/D)		2	C2OZ 3468-A
62/64	B(H/D)		2	C2OZ 3468-B
62/	S		2	C2SZ 3468-A
61	S		2	C1SS 3468-D
60/62	X	5/8" -18 x 3 3/4" thread	2	C0DD 3468-F
62/63	X (6 cyl.)	11/16"-18 x 4 3/8" thread	2	C2DZ 3468-A
63	X (8 cyl.)		1	C3DZ 3468-A
64	X (8 cyl.)		2	C4DZ 3468-A
64	X (6 cyl.)		2	C4DZ 3468-B
62/	B	Bolt (strut to arm)-1/2"-20 x 1 5/8"-serrated	4	376250-S7-8 (BB390V)
		Nut-1/2"-20		33882-S8(M24)
		Lockwasher-1/2"		34809-S8(X68)
62/64	B	Nut-slotted (strut to bracket)-9/16"-18	2	34033-S18(M11)
		Cotter pin-1/8" x 1"		72035-S7-8(N51)
61/63	S	Bolt (strut to arm)-5/8"-11 x 2 3/32"-square head	4	376269-S7-8(BB842)
64	S	Bolt (to arm)-5/8"-18 x 2 3/32"-square head	4	378984-S2(BB836D)
		Nut-5/8"-11		356085-S8(MM14)
		Lockwasher-5/8"		34811-S2(X71)
		Locknut-5/8"-18		371171-S(MM161)
60/61	X	Bolt (strut to arm)-7/16"-20 x 1 5/16"	4	373862-S(BB231A)
62/	X (6 cyl.)	Bolt (strut to arm)-7/16"-20 x 1 1/2"	4	352621-S(BB234)
63/	X	Locknut(strut to underbody)-11/16"-18	4	376680-S7-8 (MM179F)
64/	X	Locknut (strut to bracket)-9/16"-18	2	34426-S7(M86)

YEAR	MODEL	DESCRIPTION	QTY.	PART NUMBER
3486-7 BRACKET ASSY. - FRONT SUSPENSION LOWER ARM STRUT MOUNTING				
62/	B	R. H.	1	C2OZ 3486-A
		L. H.	1	C2OZ 3487-A
60/62	X	"Before 10/15/61" R. H.	1	C1DZ 3486-A
		"Before 10/15/61" L. H.	1	C1DZ 3487-A
62/	X	"From 10/15/61" R. H.	1	C3DZ 3486-B
62/63	X	"From 10/15/61" L. H.	1	C3DZ 3487-A
64/	X	L. H.	1	C3DZ 3487-B
3491 COVER - STEERING WHEEL HUB - LOWER				
64	S(63B)	Light Beige Mist	1	C4SZ 3491-A
64	S(63B)	Medium Palomino	1	C4SZ 3491-B
64	S(63B)	Light Aztec Gold	1	C4SZ 3491-C
64	S(63B)	Light Silver Mink	1	C4SZ 3491-D
64	S(63B)	Light Blue	1	C4SZ 3491-E
64	S(63B)	Black	1	C4SZ 3491-F
64	S(63B)	Red	1	C4SZ 3491-G
64	S(63B)	Light Rose Beige	1	C4SZ 3491-H
64	S(63B)	Light Turquoise	1	C4SZ 3491-J
64	S(63B)	White	1	C4SZ 3491-K
3494 TUBE ASSY. - POWER STEERING PRESSURE LINE TO VALVE - Refer to Group 3A719				
3D502 BUSHING - STEERING COLUMN OPENING COVER PIVOT				
64/	S	15/64" I. D. -5/16" O. D.	2	C4SZ 3D502-A
3504 GEAR ASSY. - STEERING				

STEERING GEAR IDENTIFICATION TAG

To facilitate the identification of Ford designed steering gear parts, beginning with the 1964 models a metal identification tag is attached to the steering gear housing as shown in the illustration below.

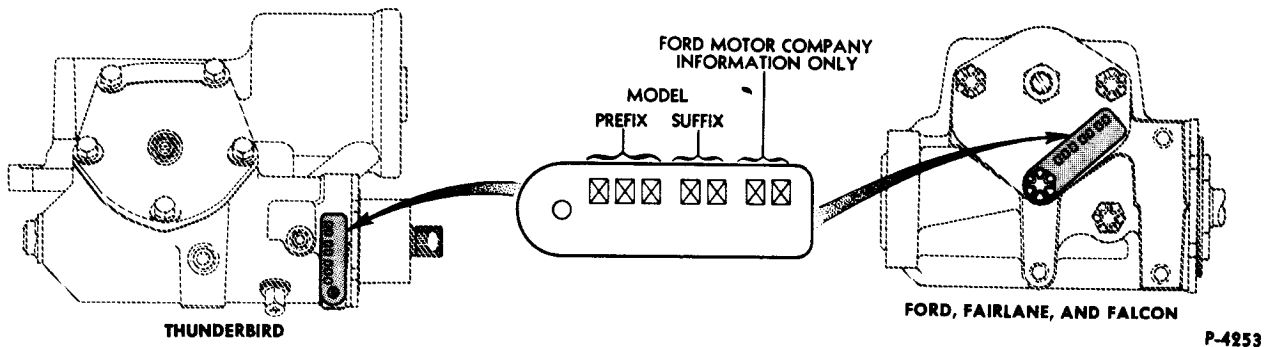

P-4253

YEAR	MODEL	DESCRIPTION	QTY.	PART NUMBER
- A -				
60	A(M/S)	#HCA-G, H, K, L-Ford built	AR	Service details
61	A(M/S)	#HCA-AH-Saginaw built	AR	Service details
	A(P/S)	#HCA-AJ-Saginaw built	AR	Service details
61/62	A(M/S)	#HCA-Z, AE, AN-Ford built, 40" long input shaft	1	C2AZ 3504-A
	A(M/S)	#HCA-BN, BW-Ford built, 40" long input shaft	1	C1AZ 3504-A
	A(P/S)	#HCA-BP-Ford built, 7 3/16" long input shaft	AR	Service details
	A(P/S)	#HCA-AB, AF, AP-Ford built, 7 3/16" long input shaft	1	C2AZ 3504-B
63/64	A	#HCA-AX, AY, BL-BX Ford built, 7 3/16" long input shaft	1	C3AZ 3504-B

Identification marking

YEAR	MODEL	DESCRIPTION	QTY.	PART NUMBER
3504 GEAR ASSY. - STEERING - continued				
- B -				
62/63	B(M/S)	#HCA-AV-7 3/16" long input shaft	1	C7OZ 3504-A
62/64	B(P/S)	#HCA-AW, SMA-F-7 3/16" long input shaft	1	C7OZ 3504-A
64/	B(M/S)	#HCA-BU-39 1/2" long input shaft	1	C4OZ 3504-A
- S -				
60	S(M/S)	#HCA-J	AR	Service details
61/62	S(P/S)	#HAA-AY, BJ-pin lock type coupling	1	C1SZ 3504-A
62	S(P/S)	#HAA-BD-rubber insulated type coupling- with offset mount flange	1	C2SZ 3504-L
63/64	S(P/S)	#HAA-BF, BG	1	C4VY 3504-A
- X -				
60/63	X-6 cyl.(M/S)	#HCC-B, C, K, M, S, T, W, X-40" long input & 1" dia. sector shaft	1	C3DZ 3504-D
63	X-8 cyl.(M/S)	#HCC-AF, AS-40" long input shaft & 1" dia. sector shaft	1	C3DZ 3504-G
63	X(P/S)	#HCC-AJ, AK, BA-40" long input shaft & 1" dia. sector shaft	1	◇C3DZ 3504-H
		#HCC-AG-40" long input shaft & 1 1/8" dia. sector shaft	1	C3DZ 3504-E
64	X(P/S)	#HCC-AN, AN1-39" long input shaft & 1" dia. sector shaft	1	C4DZ 3504-A
64/	X-6 cyl.(M/S)	#HCC-AM, AM1-39" long input shaft & 1" dia. sector shaft	1	C4DZ 3504-A
64/	X-8 cyl.(M/S)	#HCC-AP, AP1-39" long input shaft & 1 1/8" dia. sector shaft	1	C4DZ 3504-B
60	X	Bolt (housing to underbody) -3/8"-16 x 3"	3	45534-S8(B95)
61/62	X	Bolt (housing to underbody) -3/8"-16 x 3 1/4"	3	354580-S(BB167)
63/	B, X	Bolt (housing to underbody) -7/16"-14 x 3 1/4"	3	C1AE 6A527-C
60/62	X	Washer-Flat-3/8"	3	373308-S(XX336)
		Lockwasher-3/8"	3	34847-S8(X74)
63/	X, S	Washer-flat-39/64"	3	359820-S8(XX203)
60	A	Bolt (housing to frame)-lower-7/16"-14x3 3/4"	3	351988-S8(BB187)
60/62	S		3	
62/	B	Bolt (housing to underbody)	3	
62/	B	Washer-flat-7/16"	3	351428-S7(XX166)
63/64	S	Bolt (housing to underbody) -7/16"-14 x 3 3/32"	3	C1DZ 6065-B
61/64	A	Bolt (housing to frame) -7/16"-14 x 4 21/64"	3	B6AZ 6065-A
60/	A, B, S, X	Lockwasher-7/16"		34808-S8(X67)
3506 CLAMP ASSY. - STEERING COLUMN				
60	A		1	C1TT 3287-C
62/	B		1	C2OZ 3506-B
63	A (fixed column)		1	
64	S(63A, 76)		1	C4SZ 3506-D
64	S(63B)		1	C4SZ 3506-C
60	A	Bolt (clamp) -7/16"-20 x 2 1/2"	1	*23548-S7-8
		Locknut -7/16"-20		34447-S2(M83)
62	B	"Before 6/4/62" Bolt (clamp) -5/16"-24 x 2 1/2"	2	45521-S7-8(B164A)
62/	B	"From 6/4/62" Stud (clamp to brkt.) -5/16"-18 & 5/16"-24 x 3 3/4"	2	354527-S(WW15)
63	A (fixed column)		2	
3D507 RETAINER - POWER STEERING CYLINDER STUD SEAL				
63/	X	1 15/16" I.D.	1	C3DZ 3D507-A
64/	B		1	
3509 TUBE ASSY. - STEERING COLUMN - PRIME - Also refer to Group 3514				
60	A (with S/T & O/D)	"Before 1/15/60"	1	C0AA 3509-CP
60	X (with S/T)	Flange & bearing	1	C0DF 3509-AP
60	X (with F/M/2)	Flange & bearing	1	C0DF 3509-CP
61/62	X (with S/T)	Flange & bearing	1	C1DD 3509-AP
61/62	X (with F/M/2)	Flange & bearing	1	C1DD 3509-BP
62	X (4 speed trans.)	Includes flange -N/R (1-69)	1	*C2DZ 3509-A
63	X (4 speed trans.)	Includes flange	1	C3DZ 3509-C
64	X (4 speed trans.)	Includes flange	1	C4DZ 3509-B

* Identification Marking

◇ Preload must be set to 3-4 inch/lbs. and mesh load to 8-9 inch/lbs.

YEAR	MODEL	DESCRIPTION	QTY.	PART NUMBER
3511 FLANGE and PIN ASSY. - STEERING COLUMN TUBE				
- A -				
60/62	A(column shift with A/T)		1	B8A 3511-A
62	A(floor shift with A/T)		1	C2AZ 3511-A
63	A(column shift with M/T)	Consists of 1 each C5AZ 3511-A flange, C4AZ 7335-B bushing & C4AZ 7D460-A washer	1	C3AZ 3511-C
64	A(all transmissions)-floor shift		1	
64	A(column shift with M/T)		1	C5AZ 3511-A
63/64	A(column shift with A/T)		1	C5AZ 3511-B
- B -				
62/	B(column shift with A/T)		1	C5OZ 3511-B
63	B(floor shift)	Consists of 1 ea. C5AZ 3511-A flange, C4AZ 7335-B bushing & C4AZ 7D460-A washer	1	C3AZ 3511-C
64	B(floor shift)		1	C5AZ 3511-A
62/	B(column shift with M/T)		1	C5OZ 3511-A
- S -				
60	S		1	B8S 3511-B
61/63	S		1	C2SZ 3511-A
64	S		1	C5AZ 3511-B
- X -				
60/62	X(with M/T)		1	CIDD 3511-AP
60/62	X(with A/T)		1	CIDD 3511-BP
63/	X(with M/T)		1	C5DZ 3511-A
63/	X(with A/T)	1963/64 also use 1-C5TZ 7A216-A	1	C5DZ 3511-B
63	A, B(with column shift - M/T)	Washer-flat (flange to gear shift lever socket)-1 7/16"	1	376103-S(XX281C)
63	A(column shift - A/T)	Washer-spring (flange to trans. control lever socket)-1"	1	370948-S(XX365)
64/	S		1	
3C511 SUPPORT - POWER STEERING PUMP - Also refer to Group 3A732				
60/62	A (8 cyl. 292)		1	B8AZ 3C511-A
60/	A (8 cyl. 332, 352, 390)	Adjusting bracket-air conditioning	1	B8AZ 3C511-B
60	S (8 cyl. 352)		1	
60/	A (8 cyl. 332, 352, 390)-with A/C	Bracket	1	B8AZ 3C511-C
60	S (8 cyl. 352)-with A/C		1	
62	B (8 cyl.)		1	C2OZ 3C511-B
63/64	B(6 cyl. 170)-with A/C		1	C3OZ 3C511-A
62	B(6 cyl. 170 with F/M/2)		1	
63/64	X (6 cyl.)	"Before 3/2/64"	1	
64	X (6 cyl.)	"From 3/2/64"	1	C4DZ 3C511-A
60/	A(8 cyl.)	Bolt (support to water pump)-5/8"-18 x 1 1/8"	1	370851-S8(BB268)
60/62	A (8 cyl. 292)	Bolt (support to water pump)-5/16"-18x4 5/8"	1	352435-S(BB147)
62/	B(8 cyl.)	Bolt (support to cylinder head)-3/8"-16 x 1 1/4"	1	359266-S8(BB157)
63	A(8 cyl. 260)		1	
		Washer-flat-3/8"	2	351385-S7(XX158)
		Lockwasher-3/8"	1	34807-S8(X66)
62	A (8 cyl. 292)	Bolt (support to cyl. head)-3/8"-16 x 1 1/4"	1	20428-S7-8(BB82)
3512 GROMMET - STEERING COLUMN TO DASH				
64	A(fixed column)		1	C4AZ 3512-A
60	S		1	B9S 3512-A
62	A (65B, 76B)		1	
63	A(fixed column)		1	
60/	X		1	B5S 3512-A
3A512-3 PLUG - POWER STEERING REACTION CONTROL SPRING				
61/	A, B, X	Spindle end	1	B9M 3A512-A
61/	A, B, X	Cap end	1	B9M 3A513-A
3513 SEAL - STEERING COLUMN WEATHER				
63	A(with Moveable Column)		1	C3AZ 3513-A
64	A(with Moveable Column)		1	C4AZ 3513-A
62/	B		1	C2OZ 3513-A
61/64	S (moveable column)		1	C1SS 3513-D
61/63	X (with S/T)		1	C1DD 3513-A
61/63	X (with F/M/2)		1	C1DD 3513-B
64/	X	Cut hole for S/T shift lever	1	C4DZ 3513-B
62/	B	Screw (attaching)-No. 14-10 x 1"-tapping	5	42154-S7-8(U256)

YEAR	MODEL	DESCRIPTION	QTY.	PART NUMBER
3514 TUBE ASSY. - STEERING COLUMN - PRIME - Also refer to Group 3509				
- A -				
61/62	A 8 cyl. (with C/M)		1	C2AZ 3514-CP
61/62	A (with S/T or O/D)		1	C2AZ 3514-DP
63	A(with S/T & O/D)	With fixed column	1	C3AZ 3514-A
63	A(with F/M/2 & C/M) -except 65B & 76B	With fixed column	1	C3AZ 3514-B
63	A(65B, 76B with F/M/2 & C/M)-exc.console shift	With fixed column	1	
63	A(65B, 76B)-with 4 speed S/T-console shift	With fixed column	1	C3AZ 3514-E
63	A(except 65B & 76B)-with F/M/2 & C/M	With moveable column	1	C3AZ 3514-J
63	A(65B, 76B)-with F/M/2 & C/M - "Before 2/25/63"	With moveable column	1	C3AZ 3514-F
64	A (8 cyl.)	With fixed column & C4 or CM	1	C4AZ 3514-J
64	A(except 57C, 63C, 76B)	With fixed column & S/T	1	C4AZ 3514-C
64	A(57C, 63C, 76B)-8 cyl.	With floor shift & all trans.	1	C4AZ 3514-D
64	A	With moveable column & C/M	1	C4AZ 3514-H
- B -				
62/63	B(automatic transmission)		1	C3OZ 3514-D
64/	B(C4)		1	C5OZ 3514-A
62/	B(S/T or O/D)		1	C5OZ 3514-B
63/	B(8 cyl. 289)-4 speed S/T		1	C5OZ 3514-C
- S -				
61	S(fixed column)	N/R (1-69)	1	★C1SZ 3514-B
63	S		1	C3SZ 3514-A
64	S		1	C4SZ 3514-C
- X -				
60/61	X (with S/T)	"Before 11/10/60"	1	C0DF 3514-AP
61	X	"From 11/10/60"	1	★C1DD 3514-AP
62	X(with S/T)	N/R (1-69)	1	★C2DZ 3514-A
63	X(with S/T)-except 4 speed		1	C3DZ 3514-A
63/64	X(with F/M/2)		1	C3GY 3514-A
64	X(3 speed S/T)		1	C4DZ 3514-A
64	X(C4)		1	C4DZ 3514-B
64	A	Set screw (to lock or unlock trans. control selector on track)-No. 10-32 x 1 7/16"	1	378561-S2(UU26B)
		Nut-No. 10-32		34079-S7(M163)
63/	A	"From 12/17/62"	2	377944-S2 (BB445N)
61/	S (moveable column)	Bumper (tube) -Rubber	2	373628-S(CC-28)
3D514 SPRING - STEERING COLUMN INSTRUMENT PANEL OPENING COVER				
64	S		2	C4SZ 3D514-A
3517 BUSHING OR BEARING ASSY. - STEERING COLUMN - UPPER and LOWER				
64/	A, S	Bearing-upper-1 3/16" O.D.	1	C5SZ 3517-A
61/63	A, S	Bearing-upper-1 3/16" O.D.	1	C3AZ 3517-A
62/63	B		1	
61	X		1	
64/	B(P/S)		1	
64/	B(without P/S)	Bearing-upper-1 21/64" O.D.	1	C4OZ 3517-A
61/62	S (moveable column)	"Before 4/13/62"	1	C1SZ 3517-A
62/	X		1	
60	A, S, X	Bearing-upper-1.44" O.D.	1	C3DZ 3517-A
61/	A		1	
61/	S	Ring (bearing retaining)-upper-3/4"	1	372876-S(QQ38A)
63	B		1	
64/	B(P/S)		1	
61/	A		1	
61/	S	Ring (bearing retaining)-lower-3/4"	1	372875-S(QQ88)
63	B		1	
64/	B(P/S)		1	

YEAR	MODEL	DESCRIPTION	QTY.	PART NUMBER
3518 SLEEVE - STEERING COLUMN UPPER BEARING				
60	A, S	.75" I.D. -.98" O.D.	1	B1AZ 3518-A
60/	X		1	
60/	B(without P/S)		1	
62	A (65B, 76B)	1.04" I.D. -.352" thick	1	C1SZ 3518-B
61/64	S		1	
62/63	B		1	
64/	B(P/S)		1	
63/	A		1	
3A519 BUSHING - POWER STEERING CONTROL VALVE SPOOL				
61/64	A	Cap end-.9/16" I.D. -.51/64" O.D.	1	C2AZ 3A519-A
62/	B, X	Cap end-1/2" I.D. -.51/64" O.D.	AR	C2OZ 3A519-B
61/64	A	Sleeve end	1	
3520 SPRING - STEERING COLUMN UPPER BEARING				
60	A	.78" I.D. -1.38" long	1	B8A 3520-A
64/	A		1	C4AZ 3520-A
63/	X		1	C3DZ 3520-A
64	S		1	C4VY 3520-A
60/62	X		1	C0DF 3520-A
60	A	Washer-flat (spring seat)-3/4"	1	351811-S8(X232)
60	S		1	
3523 GUIDE - STEERING GEAR BALL RETURN				
61/	A(without P/S)		4	C5AZ 3523-B
61/64	S		4	WAN 3523-A
60/	X		4	C0DR 3523-A
60/64	A, B	Consists of (4) C7OZ 3523-A guides and (1) C7OZ 3544-A clamp	1	C7OZ 3523-B
60	S	Saginaw steering gear	1	
60	X		1	
3524 INPUT SHAFT - STEERING GEAR RACK and WORM				
60	A(M/S)	39 3/4" long	1	C0AZ 3524-B
61	A(M/S)	Use w/ Saginaw gear	1	C1AZ 3524-C
61	A(P/S)	Use w/ Saginaw gear	1	C5TZ 3524-B
61/64	A(M/S)	Use w/ Ford gear-approx. 40" long	1	
61/64	A(P/S)	Use w/ Ford gear-7 3/16" long	1	C3AZ 3524-B
62/64	B	7 3/16" long	1	C3AZ 3524-B
64/	B	39 1/2" long	1	C4OZ 3524-A
60	S(M/S)		1	B8S 3524-A
61/64	S(P/S)		1	C0LR 3524-A
60/63	X	40" long	1	C0DZ 3524-A
64/	X(M/S)	39" long	1	C4DZ 3524-A
64	X(P/S)		1	
3524 STEERING SHAFT ASSY. - STEERING COLUMN				
61/62	A(column shift)	32 3/16" long	1	C1AZ 3460-A
62	A(floor shift)	31" long -Not replaced	1	★C1MM 3460-A
63	A(fixed column)	W/flange	1	C3AZ 3460-A
63	A(moveable column)	W/o flange	1	C3AZ 3524-A
64	A(fixed column)	W/flange	1	◇C4AZ 3460-A
64	A(moveable column)	W/o flange	1	◇C4AZ 3524-A
62/64	B		1	C2OZ 3460-A
60/	X	Part of steering gear, see basic 3524 input shafts		

◇ Includes 3517 bearing, retainer ring, nut & washer

FORD CAR PARTS

YEAR	MODEL	DESCRIPTION	QTY.	PART NUMBER
3A525 FLANGE and INSULATOR COUPLING - STEERING GEAR INPUT SHAFT TO STEERING COLUMN SHAFT				
61/62	A(M/S)		1	C2AZ 3A525-A
63/64	A(M/S)-fixed column		1	C3AZ 3A525-B
61/62	A(P/S)		1	C2AZ 3A525-B
63/64	A(P/S)-fixed column		1	C3AZ 3A525-A
63/64	A-moveable column		1	C3AZ 3A525-C
62/64	B(M/S)		1	C2AZ 3A525-A
62/64	B(P/S)		1	C2AZ 3A525-B
61	S		1	C1SS 3A525-C
62	S	"Before 4/13/62" (2) holes splined	1	C3SZ 3A525-B
62/64	S	"From 4/13/62" (1) hole splined	1	C4SZ 3A525-A
61/	A, B, S, X	Bolt-3/8"-24 x 1 1/4" (to retain coupling)	AR	358794-S(BB815AB)
63/	A	Bolt-5/16"-24 x 1" (to retain coupling)	AR	377937-S(BB210B)
61/	A, B, S, X	Nut-5/16"-24 (coupling studs to shaft flange)	2	34443-S(M79)
		Lockwasher-5/16"	2	34906-S8(X98)
3C525 COVER ASSY. - MOVEABLE STEERING COLUMN OPENING				
61/62	S	Black	1	C2SZ 3C525-S
63	S	Black	1	C3SZ 3C525-A
		Light Blue	1	C3SZ 3C525-B
		Light Beige	1	C3SZ 3C525-C
		Light Green	1	C3SZ 3C525-D
		Red	1	C3SZ 3C525-E
		Light Turquoise	1	C3SZ 3C525-F
		Chestnut	1	C3SZ 3C525-G
		Light Silver Blue	1	C3SZ 3C525-H
		Gold	1	C3SZ 3C525-J
		Rose Beige	1	C3SZ 3C525-K
64	S(63A, 76)		1	C4SZ 3C525-E
64	S(63B)		1	C4SZ 3C525-F
64	S	Washer-flat (cover to body structure)-No. 10	3	378431-S(XX55B)
64	S	Washer-flat (lever to shroud)	3	
64	S	Washer-flat (lever to cover)	8	
64/	S	Washer-spring (shroud to cover)-3/16"	AR	378733-S(XX360)
64/	S	Washer-spring (lever to cover)	AR	
64/	S	Spring nut (lever to cover)-3/16"	4	372927-S2(MM260)
64/	S	Pin (lever to cover)-3/16" x 5/8"	4	378873-S(NN63B)
64/	S	Pin (lever to shroud)	AR	
3C528 BOOT - POWER STEERING CYLINDER - Supplied in 3C651 kits				
3530 SHROUD - STEERING COLUMN				
63	S(except 63B)	R. H.	1	C3SZ 3530-A
61/62	S (moveable column)	R. H.	1	
63	S	L. H.	1	C3SZ 3530-B
63	S(63B)	Wood Grain-R. H. -Beige	1	C3SZ 3530-F
		-Black	1	C3SZ 3530-D
		-Blue (light)	1	C3SZ 3530-E
		-Chestnut	1	C3SZ 3530-J
		-Gold (light)	1	C3SZ 3530-L
		-Red	1	C3SZ 3530-G
		-Rose (light)	1	C3SZ 3530-M
		-Silver Blue (light)	1	C3SZ 3530-K
		-Turquoise (light)	1	C3SZ 3530-H
63	S(63B)-Monaco Special	White-R. H.	1	C3SZ 3530-N
		White-L. H.	1	C3SZ 3530-R
61/	S (moveable column)	Bumper (rubber)	1	373628-S(CC28)

YEAR	MODEL	DESCRIPTION	QTY.	PART NUMBER
3A533 KIT - DRAG LINK BALL STUD REPAIR				
60	A, S (without Power Steering)		1	B2AZ 3A533-A
Consists of				
	1-AB 3311-C Stud	1-72089-S Cotter pin	1-B2A 3333-A Dust cover	2-AB 3327-B Springs
	1-B2A 3332-A Seal	1-351059-S Nut	1-AB 3328-B Plug	2-B2A 3326-A Bumpers
	1-72035-S7-8 Cotter pin	1-358032-S8 Fitting	2-AD 3320-A Seats	
3A533 KIT - POWER STEERING CONTROL VALVE BALL STUD REPAIR				
60/64	A	Consists of	1	C2AZ 3A533-A
60/62	S	2-AJ 3320-A Seat 1-AJ 33711-A Spring	1	
60/	B, X	1-AJ 33327-A Bumper 1-C2AZ 3A728-A Clamp	1	
		1-C0AA 3A533-A Stud 1-C7OZ 3A729-A Cover		
		1-C2AZ 3C706-A Seal 2-33119-S8 Screw		
3C533 PLATE - MOVEABLE STEERING COLUMN SHROUD COVER RETAINING				
61/63	S		1	C1SS 3C533-A
3538 PLUG - STEERING GEAR HOUSING OIL FILLER				
60/	A, B, X	5/8"-24	1	B6A 3538-A
60	S		1	
60	X	3/8"-18 Saginaw steering gear	1	87710-S(P16)
62	A		1	
3C538 KIT - SEAL and GASKET - INTEGRAL POWER STEERING GEAR				
61/64	S		1	C1VY 3C538-A
Consists of				
	1-C1SZ 3581-A Gasket	1-C1VR 3805-A Seal	1-87078-S94	"O" Ring
	2-C2SZ 3591-A Seal	1-C1AZ 7A294-A Seal	1-352109-S7	Snap Ring
	1-C0LR 3591-E Seal	1-87022-S94	1-97619-S	Snap Ring
	1-C3SZ 3591-A Seal	1-87025-S94	1-354278-S7	Snap Ring
	1-C2SZ 3581-A Gasket	1-87026-S94	1-87079-S94	Seal
	1-C0LR 3B699-A Seal		1-87142-S94	Seal
			1-372454-S94	Seal
3-3538 ELEMENT ASSY. - POWER STEERING OIL RESERVOIR FILTER				
62/	A, B, S	"From 5/1/62"	1	B7A 33538-A
63/	X		1	
3A540 CYLINDER ASSY. - POWER STEERING				
60	A	Stamped 128027	1	C0AA 3A540-B
61/62	A		1	C2AA 3A540-A
63/64	A		1	C3AZ 3A540-A
62/63	B	Includes ball stud	1	C2OZ 3A540-A
64/	B	Includes ball stud	1	C3OZ 3A540-A
60	S		1	C0SS 3A540-A
63/64	X(8 cyl.)	Includes ball stud	1	C3DZ 3A540-A
63/	X(6 cyl.)	Includes ball stud	1	C3DZ 3A540-B
60/	A, B, S	Nut (cylinder to idler arm bracket)-3/8"-24	1	33925-S7(M33)
63/	X	Nut (cylinder to mounting bracket)	1	
60/	A, B, S	Check nut (cyl. to idler arm brkt.)-3/8"-24	1	45218-S8(M172)
63/	X	Check nut (cylinder to mounting bracket)	1	
62/	B (1963/ A, X)	Nut-castle (cylinder to idler arm)-9/16"-18	1	34033-S18(M111)
60/	A, B, S, X	Seat-5/16" tube-aluminum	2	373430-S(TT5)
60/	A, B, S, X	Snap ring (scraper retiner)	1	371033-S(QQ77)
3544 CLAMP - STEERING GEAR BALL RETURN GUIDE				
60/64	A, B		1	B8A 3544-A
60	S		1	
60	X	Saginaw	1	
61/64	A(without P/S)		1	C5AZ 3544-B
61/64	S		1	WAN 3544-B
60/	X		1	C0DR 3544-A
60/64	A, B (1960 S)	Screw & washer assy. (Clamp to rack)-	1	352518-S(BB80)
60	X (Saginaw)	1/4"-28 x 5/16"	1	
60/	X	Screw & washer (clamp)-No. 10-32 x 3/8"	2	372133-S(BB625C)
61/	S		2	

FORD CAR PARTS

SECTION 35

YEAR	MODEL	DESCRIPTION	QTY.	PART NUMBER
3A545 ROD - POWER STEERING PISTON				
61/64	S		1	C1VR 3A545-B
3-3547 RING - POWER STEERING OIL RESERVOIR ORIFICE				
60/	A, S, X	53/64" I. D.	1or2	B5A 33547-A
62	B (8 cyl.)		2	
63/	B		2	
3548 HOUSING ASSY. - STEERING GEAR				
63/64	A		1	C3AZ 3548-A
62/	B		1	C2OZ 3548-D
62	S (use with C2SZ 3504-L)	Identify by offset mounting flange to accommodate rubber insulators-N/R (1-69)	1	*C2SZ 3548-C
61/64	S (except 1962 with C2SZ 3504-L)	Includes (1 each) C4SZ 3B730-A Plug & 87025-S94 "O" Ring	1	C1SZ 3548-A
63/	X(8 cyl.)-without P/S	With 1 1/8" sector shaft	1	C7ZZ 3548-A
63/	X	With 1" sector shaft	1	C3DZ 3548-E
60/	A, S, X, U	Plug (expansion)-1 5/16"	1	351701-S(PF87)
61/	S	Seat (oil intake tube)-5/16" tube	1	374309-S(TT5A)
61/	S	Seat (oil outlet tube)-3/8" tube	1	374480-S(TT7A)
3552-3 CUP - STEERING WORM BEARING				
60/	A, B, S, X	Upper & lower	2	C2AZ 3552-A
3C557 BRACE - MOVEABLE STEERING COLUMN TRACK- Also refer to Group 3C762				
63	A	Outer	1	C3AZ 3C557-A
64	A		1	C4AZ 3C557-A
64	A	Outer	1	C4AZ 3C557-B
63	A (Automatic transmission)		1	C3AZ 3C557-C
64	S	Outer	1	C4SZ 3C557-A
64	S		1	C4SZ 3C557-B
63	A	Screw (brace to track)-5/16"-18 x 1 43/64"	1	377978-S2 (BB817W)
63/	A (Automatic transmission)	Bolt & lockwasher (brace to brake pedal support bracket)-5/16"-18 x 7/16"	1	350211-S(BB413)
63/	A (Automatic transmission)	Nut (brace to track)-5/16"-18	1	33797-S7(M50)
		Washer-flat-5/16"		44722-S8(X19)
64	S	Locknut (brace to cowl side bracket stud)-5/16"-18	1	34392-S7(M93)
3558 SHAFT and BEARING ASSY. - MOVEABLE STEERING COLUMN - FLEXIBLE				
63	S	Less bearing	1	C3SZ 3558-B
64	S	Less bearing	1	C4SZ 3558-A
61/62	S	Pin (shaft to sector shaft)-3/16" x 1 1/2"	1	353909-S8(NN109)
3B559 SHAFT - POWER STEERING PUMP ROTOR				
60/	A, B, S, X	Eaton Pump-3.728" long	1	C2AZ 3B559-A
		Snap ring (rotor to housing)	1	359290-S(QQ49)
3C560 STOP - POWER STEERING CONTROL VALVE SPOOL TRAVEL REGULATOR				
61/	A, B, X		1	C1AA 3C560-A
60	A, S		1	
3D560 PAD - MOVEABLE STEERING COLUMN LOCKING BRACKET				
64/	A (except S/T)		1	C4AZ 3D560-A
64/	S		1	
3A561 VALVE ASSY. - POWER STEERING PUMP				
60	A, S	Stamped "H"	1	C0AA 3A561-A
61/62	A (except 6 cyl. 223 & 8 cyl. 292)		1	C1AA 3A561-A
62	B, S		1	
63/64	A (8 cyl. 352, 390)		1	
61	S	Stamped "E"	1	C1SS 3A561-A
61/64	A (6 cyl. 223 & 8 cyl. 260, 289, 292)		1	
63/	B, X		1	
63/	S	Stamped "C"	1	B8LY 3A561-A

YEAR	MODEL	DESCRIPTION	QTY.	PART NUMBER
3D561 RETAINER - MOVEABLE STEERING COLUMN TRACK BEARING				
64/	A		2	C4AZ 3D561-A
64/	S		2	
		Screw-set (adjusting)-5/16"-32 x 11/16"	2	378562-S2(UU38)
		Nut-5/16"-32		378563-S2(MM54D)
3562 BRACKET - POWER STEERING PUMP SUPPORT TO EXHAUST MANIFOLD				
60/62	A (8 cyl. 292)		1	B8A 3562-B
62/	B (6 cyl. 170)-with Automatic trans.	Upper	1	C3OZ 3562-A
63/64	X (6 cyl.) "Before 3/2/64"		1	
62/64	B (6 cyl.)-with Automatic trans.	Lower	1	C2OZ 3562-A
63/64	X (6 cyl.) "Before 3/2/64"		1	
64	X (6 cyl.) "From 3/2/64"	To pump	1	C5ZZ 3562-A
64	X (6 cyl.) "From 3/2/64"	To cylinder head	1	C5ZZ 3562-B
60/62	A (8 cyl.)	Bolt (bracket to cylinder head)-3/8"-16 x 1 1/4"	1	20428-S7-8(B82)
		Washer-flat-3/8"		44727-S8(X24)
62/	B (6 cyl.)-with Automatic trans.	Bolt (upper to lower brkt.)-3/8"-24 x 1 1/2"	1	20469-S8(B174)
63	X (6 cyl.)		1	
		Lockwasher-3/8"		34807-S8(X66)
		Washer-flat-3/8"		352981-S(XX143)
		Washer-flat-13/32"		354193-S(XX141)
3C562 INSULATOR - POWER STEERING CONTROL VALVE LINKAGE STOP				
61/	A		2	C1AA 3C562-A
62/	B		2	C2OZ 3C562-A
63/64	X		2	
3B563 REINFORCEMENT - POWER STEERING OIL RESERVOIR ORIFICE				
60/	A (8 cyl.)		1	B5AZ 3B563-A
60/	S		1	
62	B (8 cyl.)		1	
63/	B, X		1	
3C563 SPRING - POWER STEERING CONTROL VALVE REACTION LIMITING				
61/62	A		2	C1AA 3C563-A
62/63	B		2	
63/	A		2	C3AZ 3C563-A
64/	B, X		2	
3B564 INSULATOR - STEERING COLUMN LOWER FLANGE - Also refer to Group 3674				
60/	X		1	C3DZ 3B564-A
3A570 SPRING - POWER STEERING PUMP FLOW CONTROL VALVE				
60/	A, B, S, X		1	B8AZ 3A570-A
3C570 BRACKET - STEERING COLUMN LOWER TRACK SUPPORT STRUT				
61/	S		1	C3SZ 3C570-A
3571 BALL and CAGE ASSY. - STEERING WORM THRUST BEARING				
60/	A, B, S, X		2	C2AZ 3571-A
3C571 TRACK ASSY. - MOVEABLE STEERING COLUMN				
63	A		1	C3AZ 3C571-C
64	A	F/M/3 & C/M	1	C4AZ 3C571-A
63	S		1	C3SZ 3C571-A
64/	S		1	C5SZ 3C571-A
61/	S	Bolt (track to locking plate)-3/8"-16 x 1'shoulder	1	373637-S7-8 (BB444E)
		Washer-flat-3/8"		44727-S8(X24)
		Washer-flat-5/16"		44722-S8(XI9)
63	A	"Before 2/13/63"	2	354135-S7-8 (BB155A)
		Washer-flat-3/8"		356951-S(XX134)
63/	A	"From 2/13/63"	2	359266-S8(BB157)
		Bolt (track to pedal support)-3/8"-16 x 1 1/4"		
3C571 GUIDE - INSTRUMENT PANEL MOVEABLE STEERING COLUMN OPENING COVER				
63/	A	Nylon	2	C3AZ 3C571-A

FORD CAR PARTS

SECTION 35

73

YEAR	MODEL	DESCRIPTION	QTY.	PART NUMBER
3C574 BRACKET - MOVEABLE STEERING COLUMN TRACK SUPPORT				
64/	S		1	C4SZ 3C574-A
64/	S	Bolt (to floor pan)-7/16"-20 x 7/8"-shoulder	1	379076-S7-8 (BB505A)
3575 SHAFT - STEERING GEAR SECTOR				
60	A, S	11 1/2" long	1	B8A 3575-A
61	A	11 3/32" long	1	C1AZ 3575-A
62/64	A		1	
61	A	11" long	1	C1AZ 3575-B
62/64	A (P/S)		1	
62/	B	1" dia. shaft	1	C2OZ 3575-B
61/64	S	7/8"-14 x 11.6"	1	C3SZ 3575-A
60	X	Saginaw steering gear -7/8"-14 x 11.51"	1	MC 3575-A
61	A	"Before 9/16/60" Saginaw steering gear	1	
62/	X(except 8 cyl. w/o P/S)	1" diameter shaft-3/4"-16 x 9.16"	1	C3DZ 3575-F
60/61	X		1	
63	X(8 cyl. w/o P/S)	1" diameter shaft-slot at sector shaft arm end	1	C3DZ 3575-D
63/	X(8 cyl. w/o P/S)	1 1/8" diameter shaft-7/8"-14 x 9.46"	1	C3DZ 3575-E
3C575 STRUT - LOWER TRACK SUPPORT				
61/	S (moveable column)		1	C1SS 3C575-C
3576 BEARING ASSY. - STEERING SECTOR SHAFT				
60	A, S	Bushing-1 1/8" I. D. -1 1/4" O. D. -1 3/8" long	2	B8A 3576-A
60	X	Saginaw steering gear	2	
61	A	"Before 9/16/60" Saginaw steering gear-1 1/8" I. D. -1 3/8" O. D. -1" long	2	C1AZ 3576-A
61	A	"From 9/16/60" Bushing-use with C1MR 3504-C, D, F & G -1 1/8" I. D. -1 3/8" O. D. -1" long	2	C1AZ 3576-B
62/64	A		2	
62/	E		2	
63	X (with 1 1/8" shaft)	"From 3/5/63"	2	
64	X(8 cyl.)-with 1 1/8" shaft & flanged needle bearing	Lower	1	
60/	X(with 1" shaft)	Bushing-1" I. D. -1 1/8" O. D. -1 1/4" long	2	C0DR 3576-A
63	X(with needle bearings in housing)-with 1" shaft	1" I. D. -1 1/4" O. D. -1" long	2	C3DZ 3576-A
64/	X(with 1" shaft & flanged needle bearing)	Lower	1	
64/	X(with 1" shaft & flanged needle bearing)	Upper-1" I. D. -1 1/4" O. D. -1" long	1	C4DZ 3576-A
64	X(8 cyl.)-with 1 1/8" shaft & flanged needle bearing	Upper-1 1/8" I. D. -1 3/8" O. D. -1" long	1	C4DZ 3576-B
3577 SCREW - SECTOR SHAFT ADJUSTING				
60/	A, B, X	7/16"-20 x 1 15/32"	1	B8AZ 3577-A
60	S		1	
61/	S		1	WAN 3577-A
60/	A, S, X	Nut-jam (screw)-7/16"-20	1	34690-S8(M34)
61/	S	Locknut-7/16"-20	1	370580-S(MM169G)
		Washer-flat-45" I. D. - .72" O. D.	1	356395-SXXI65D)
3580 COVER - STEERING SECTOR SHAFT HOUSING				
61	A	"Before 9/16/60" Saginaw steering gear -N/R (1-69)	1	*C1AR 3580-A
61/64	A	"From 9/16/60"	1	C3AZ 3580-A
62/	B		1	
60	A, S		1	C5AZ 3580-E
61/64	S		1	C1VR 3580-A
61/	X	"From 6/21/61"	1	C1DZ 3580-A
60	X	Bolt (cover to housing)-5/16"-18 x 5/8"	3	20326-S7(B49)
		Washer-flat-5/16"	3	356414-S(XX110)
60/	A	Bolt (cover to housing)-3/8"-16 x 3/4"	3	20348-S8(B77)
60	S		3	
		Lockwasher-3/8"	3	34807-S8(X66)
61/	X	Bolt (cover to housing)-5/16"-18 x 5/8" washer head-locking	3	371065-S(BB549)
61/63	S	"Before 10/19/62" Bolt (cover to housing)-5/16"-18 x 7/8"	5	357235-S(BB136)
63/64	S	"From 10/19/62" Bolt (cover to housing)-5/16"-18 x 7/8"	5	378291-S (BB580L)

YEAR	MODEL	DESCRIPTION	QTY.	PART NUMBER
3581 GASKET - STEERING SECTOR HOUSING or HOUSING COVER				
61/	A, B	"From 9/16/60"	1	C3AZ 3581-A
60	A, S		1	
60	X	Saginaw steering gear	1	
61/62	S		1	C1SZ 3581-A
62/	S	"From 5/1/62"	1	C2SZ 3581-A
60/64	X	Housing cover	1	C3DZ 3581-A
3D581 BEARING - STEERING COLUMN RELEASE CAM				
64/	S	Nylon	2	C4VY 3D581-A
3A582 COVER ASSY. - POWER STEERING OIL RESERVOIR				
60/	A(8 cyl.)	Pump mtd. reservoir with filler neck-5 5/8" O. D.	1	C0AA 3A582-A
60	S		1	
62/	B		1	
61/	S (without A/C)		1	
63/	X(8 cyl.)-without A/C		1	
60/	S with A/C	"From 7/15/60"	1	C0SS 3A582-A
60/	A(8 cyl.)-with A/C		1	
61	S (with A/C)	Remote mounted reservoir-4 1/4" O. D.	1	C1AA 3A582-A
63/	S (with A/C)		1	
60/	A		1	
62/	B (8 cyl.)-with A/C		1	
63/	X (8 cyl.)-with A/C		1	
62	S (Sports Roadster)	Chrome -pump mounted reservoir with filler neck-5 5/8" O. D.	1	C2SZ 3A582-A
63/	X(Sprint Models)		1	
63/	X(6 cyl.)-without A/C	Includes gasket -pump mounted reservoir-less	1	C3DZ 3A582-A
60/	A(6 cyl.)	Stud (cvr. to reservoir)-5/16"-18 & 5/16"-18 x 4 5/8"	1	359841-S8(WW22)
61/	S		1	
62/	B, X (8 cyl.)-with A/C		1	
60/	A(8 cyl.), S	Stud (cover to reservoir)-5/16"-18 & 5/16"-18 x 3 7/8"	1	370894-S8(WW18)
60/	A, S	Nut-wing-5/16"-18	1	33896-S8(M182)
62/	B, X(8 cyl.)-with A/C		1	
60/	A(6 cyl.)	Washer - flat 5/16"	1	359840-S8(XX107)
62/	B, X(8 cyl.)-with A/C		1	
60/62	A(8 cyl.) (1960/S)		1	
60/	A (8 cyl.), S (1962 B-8 cyl.)	Bolt (cover to reservoir)-5/16"-18 x 3 1/2"	1	354668-S8(BB516)
63/	B, X		1	
60/	A, S	Seal	1	B9A 6570-A
62	A -6 cyl., B(with A/C)	Spring nut	1	353766-S(MM269)
63/	B, X		1	
62/	S(without A/C)	"From 6/1/62"	1	
60/	A (8 cyl. 332, 352)-with A/C		1	44722-S8(X19)
60	S (with A/C)		1	
3B584 KIT - POWER STEERING PUMP SEAL AND GASKET				
60/	A, B, S, X	For Eaton pump-Consists of 2-B5A 33547-A Ring 1-C0AA 3A642-B Gskt. 1-C2SZ 3B592-A Seal 1-EAA 6589-B Seal 1-B7A 33617-A Gasket 1-87014-S91 Ring 1-LA 33618-A Ring 1-87147-S91 Ring 1-B7A 33619-A Ring 1-372144-S Gasket 1-C0AA 3A642-A Gasket	1	C2SZ 3B584-A
3C589 KIT - POWER STEERING CYLINDER END MOUNTING BUSHING				
60	A, S	Consists of 2-Bushings 2-Washers 1-34424-S7 Locknut	1	B3AZ 3C589-A
61/62	A	Consists of 2-B9MM 33644-A Bushing 1-34424-S7 Locknut 1-353800-S8 Washer	1	C1AZ 3C589-A

FORD CAR PARTS

YEAR	MODEL	DESCRIPTION	QTY.	PART NUMBER
3590 ARM - STEERING SECTOR SHAFT				
- A -				
60	A (except P/S)		1	C0AA 3590-A
61	A (except P/S)	"From 9/16/60"	1	Use with C1MR 3504-C & G
62	A (except P/S)		1	
60	A (with P/S)		1	C0AA 3590-C
61	A (P/S)	"From 10/16/60"	1	Use with C1MR 3504-D
60/	A Special (8 cyl. 352, 390, 406, 427)-For Special Duty Performance		1	C0AA 3590-D
61	A (except P/S)	"Before 9/16/60"	1	Saginaw steering gear
61	A (P/S)	"From 9/16 to 10/16/60"	1	Use w/C1MR 3504-F
62	A (P/S)		1	
61/62	A (P/S)	"From 10/16/60 to 10/6/61"	1	Saginaw steering gear
63/64	A (P/S)		1	C1AA 3590-A
63/64	A (without P/S)		1	C3AZ 3590-A
- B -				
62/	B(P/S)		1	C2OZ 3590-B
62/	B(without P/S)		1	C3OZ 3590-C
- S -				
60	S		1	B8E 3590-C
61/64	S		1	C1SZ 3590-A
- X -				
60/	X(6 cyl.)-without P/S		1	C0DD 3590-B
63/64	X (8 cyl.)-without P/S	With 1" sector shaft	1	C3DZ 3590-A
63/64	X(8 cyl.)-with P/S	With 1" sector shaft	1	C3DZ 3590-C
63/64	X (8 cyl.)-with P/S	With 1 1/8" sector shaft	1	C3DZ 3590-F
63/64	X(8 cyl.)-without P/S	With 1 1/8" sector shaft	1	C3DZ 3590-H
63/	X(6 cyl.)-with P/S		1	C4DZ 3590-A
60/	X	Nut-castle (arm to idler arm rod)-3/8"-24	1	★34030-S8
60/	X	Nut-castle (arm to spindle arm end)	1	
		Cotter pin-3/32" x 3/4"		72016-S8(N44)
60/	X	Nut (arm to steering gear)-3/4"-16	1	34692-S8(M74)
60/	A, B, S	Nut (steering sector shaft & worm)-7/8"-14	1	351153-S(MM32)
60	X	Saginaw steering gear	1	
63/	X(8 cyl.)		1	
63/	B, X(with P/S)	Nut-castle arm to control valve & link)-1/2"-20	1	351059-S(MM66)
60/	X	Washer (arm to steering gear)-3/4" lock	1	34813-S(X71A)
3C590 KIT - POWER STEERING PISTON ROD END BUSHING				
60	A, S	Consists of 1-AJ 3652-A Spacer 1-33925-S7 Nut 2-AB 33642-B Insulators 1-45218-S8 Locknut 2-AJ 33643-A Washers	1	B7AZ 3C590-A
61/64	A	Consists of	1	C1AZ 3C590-A
62/	B	2-C1AA 3A344-A Insulator1-AJ 3652-A Spacer 2-C3AA 3A345-A Washer 1-33925-S8 Nut 1-45218-S8 Locknut	1	
3591 OIL SEAL ASSY. - STEERING SECTOR SHAFT HOUSING				
60/	A	1 5/64" I. D. -1 9/16" O. D. -1/4" thick	1	C3AZ 3591-A
62/	B		1	
60	S		1	
63	X	With 1 1/8" sector shaft	1	
61/64	S	"From 10/6/60"	1	Upper-at torsion bar
61/64	S		1	Lower-at sector shaft-1 1/4" I. D. -1 3/4" O. D.
61	S	Input shaft-1 1/8" I. D. -1 5/8" O. D. -N/R	1	★COLR 3591-E
60/	X	With 1" sector shaft	1	C0DR 3591-A
60	X	Saginaw steering gear	1	B9AZ 3591-A
61	A	"Before 10/6/60"	1	Saginaw steering gear
61/64	S	Snap ring (seal)	1	354278-S(QQ13)
3B592 SEAL ASSY. - POWER STEERING PUMP ROTOR SHAFT OIL				
60/	A, B, S, X	Eaton-belt driven-side mounted pump	1	C2SZ 3B592-A
3A594 SPRING - POWER STEERING LOWER SHAFT				
61/	S		1	C2SZ 3A594-A

YEAR	MODEL	DESCRIPTION	QTY.	PART NUMBER
3600 WHEEL ASSY. - STEERING				
60	A(Fairlane & Galaxie)	Raven Black	1	C0AA 3600-A001
61	A(Fairlane & Galaxie)	Blue	1	C1AA 3600-E220
61	A(Fairlane, Galaxie & S/W)	Green	1	C1AA 3600-E223
61	A(Galaxie & S/W)	Red	1	C1AA 3600-E269
62	A(Galaxie '500" & S/W)	Chestnut	1	C2AZ 3600-C
62	A	Blue	1	C2AZ 3600-B
62	A	Beige	1	C2AZ 3600-D
62	A	Red	1	C2AZ 3600-G
62	A (65B, 76B)	Beige & White	1	C2AZ 3600-M
62	A (65B, 76B)	Black & White	1	C2AZ 3600-J
62	A (65B, 76B)	Turquoise & White	1	C2AZ 3600-Q
63	A (moveable column)	Turquoise-17" diameter	1	C3AZ 3600-F
63	A (except 65B & 76B)-moveable column	Green-17" diameter	1	C3AZ 3600-H
63	A(moveable column)	Rose-17" diameter	1	C3AZ 3600-G
63	A(fixed column)	Black-16" diameter	1	C3AZ 3600-CA
64	A(with P/S)	Blue-16" diameter	1	C3AZ 3600-CB
63	A(fixed column)		1	
64	A(with P/S)	Red-16" diameter	1	C3AZ 3600-CC
63	A (fixed column)		1	
63/64	A (without P/S)	Black-17" diameter	1	C3AZ 3600-BA
64	A(with P/S)	Beige-16" diameter	1	C4AZ 3600-AB
64	A(with P/S)	Black-16" diameter	1	C3AZ 3600-CA
64	A(with P/S)	Turquoise-16" diameter	1	C4AZ 3600-AD
64	A(without P/S)	Beige-17" diameter	1	C4AZ 3600-C
64	A(without P/S)	Palomino-17" diameter	1	C4AZ 3600-B
64	A(without P/S)	Turquoise-17" diameter	1	C4AZ 3600-A
62	B	Turquoise Metallic -use Black - C4OZ 3600-A	1	★C2OZ 3600-F
62/64	B	Black	1	C4OZ 3600-A
62/64	B	Red	1	C4OZ 3600-E
63	B	Gold(Green) Metallic	1	C3OZ 3600-E
63	B	Green Metallic	1	C3OZ 3600-C
63/64	B	Beige	1	C4OZ 3600-D
63/64	B	Blue	1	C4OZ 3600-B
63/64	B	Turquoise	1	C4OZ 3600-F
64	B	Palomino	1	C4OZ 3600-G
64	B	Silver Mink	1	C4OZ 3600-C
60	S	White	1	B8S 3600-A
61/62	S	"Before 10/2/61"	1	C1SS 3600-C231
61/62	S	"Before 10/2/61"	1	C1SS 3600-C232
62	S	"From 10/2/61"	1	C2SZ 3600-J
63	S(except Landau)	Black	1	
62	S	Chestnut	1	C2SZ 3600-P
63	S(except Landau)		1	
63	S(except Landau)	Beige	1	C3SZ 3600-B
63	S(except Landau)	Gold	1	C3SZ 3600-C
63	S(except Landau)	Rose	1	C3SZ 3600-D
63	S(Landau)-Monaco Special	White	1	C3SZ 3600-E
64	S(except Landau)	Aztec Gold	1	C4SZ 3600-G
64	S(except Landau)	Black	1	C4SZ 3600-A
64	S(except Landau)	Red	1	C4SZ 3600-B
64	S(except Landau)	Silver Beige-Use Black - C4SZ 3600-A	1	★C4SZ 3600-C
64	S(except Landau)	White	1	C4SZ 3600-L
64	S(Landau)	Walnut wood grain	1	C4SZ 3600-K

YEAR	MODEL	DESCRIPTION	QTY.	PART NUMBER
3600 WHEEL ASSY. - STEERING - continued				
60/62	X	Black	1	C0DZ 3600-A
60/62	X	White	1	C0DZ 3600-B
62	X (Club Wagon)	White	1	C2UZ 3600-A
63	X	Beige-3 spokes	1	C3DZ 3600-E
63	X	Black-3 spokes	1	C3DZ 3600-A
63	X	Red-3 spokes	1	C3DZ 3600-D
63	X	Turquoise-3 spokes	1	C3DZ 3600-F
63	X	White-3 spokes	1	C3DZ 3600-B
63/64	X	Simulated Walnut wood grain	1	C3DZ 3600-J
64	X	"Before 5/18/64" Beige	1	C4DZ 3600-C
64	X	"From 5/18/64" Beige	1	C4DZ 3600-J
64	X	Black	1	C4DZ 3600-G
64	X	"Before 5/18/64" Blue	1	C4DZ 3600-B
64	X	"From 5/18/64" Blue	1	C4DZ 3600-H
64	X	"Before 5/18/64" Palomino	1	C4DZ 3600-F
64	X	"From 5/18/64" Palomino	1	C4DZ 3600-M
64	X	"Before 5/18/64" Red	1	C4DZ 3600-D
64	X	Turquoise	1	C4DZ 3600-L
60	A, S	Nut (wheel to shaft)-5/8"-18	1	33947-S7-8(M73)
60/61	X		1	
61/	A, B	Nut (wheel to shaft)-5/8"-18	1	350983-S(MM38B)
62/	X		1	
64/	S		1	
61/63	S	Locknut (wheel to column)-5/8"-18	1	371530-S7 (MM161A)
3D600 SPACER - POWER STEERING PUMP ADJUSTING BRACKET				
64	A(8 cyl. 352, 390)-with A/C	13/32" I.D. -13/16" O.D. -11/16" long	1	C4AZ 3D600-A
64	S		1	
3601 BOLT - POWER STEERING OIL FILTER ELEMENT SUPPORT OR COVER RETAINING				
60/64	A (8 cyl.), S	5/16"-18 & 3/4"-16	1	B4A 3601-A
62	B (8 cyl.)		1	
63/	B, X		1	
3602 MOULDING - HORN BLOWING RING SPOKE				
64	X(54B, 59B, 62B, C, 63B, C, 66B, 71B, C, D, 76A, B, 78B)		1	C4DZ 3602-A
3A609 INSULATOR - POWER STEERING HOSE				
61/	A(except 8 cyl. 260 & 289)		1	C1AA 3A609-A
63/	A (8 cyl. 260, 289)		1	C3AZ 3A609-A
62/	B, X		1	C2OZ 3A609-A
61/63	S		1	C1SS 3A609-B
64	S	Pressure hose	1	C4SZ 3A609-A
64	S	Pressure & return hoses	1	C4SZ 3A609-B
62/	B, X	Screw (insulator to underbody)-5/16"-18 x 1/2"-tapping	1	40923-S8(U264)
3A610 RETAINER - POWER STEERING HOSE INSULATOR				
60/	A (except 8 cyl. 260 & 289)		1	C0AA 3A610-A
62/	B		1	C2OZ 3A610-A
64	X (4 speed S/T)		1	
61/63	S		1	C1SS 3A610-B
64	S	Pressure hose	1	C4SZ 3A610-A
64	S	Pressure & return hoses	1	C4SZ 3A610-B
63/	X (6 cyl.)		1	C3DZ 3A610-A
63/	X (8 cyl.)		1	C3DZ 3A610-B

YEAR	MODEL	DESCRIPTION	QTY.	PART NUMBER
3B610 RETAINER - STEERING COLUMN UPPER BEARING - Also refer to Group 3839				
61/63	S		1	C1SS 3B610-A
61/63	S	Screw (retainer to flange)-No. 8-15x3/8"tapping	3	52720-S8(U380)
3A611 BRACKET - POWER STEERING HOSE INSULATOR				
60/	A (except 8 cyl. 260 & 289)	Hose bracket	1	C0AA 3A611-A
63/	A(8 cyl. 260, 289)		1	C3AZ 3A611-A
64	A(8 cyl. 289)		1	C4AZ 3A611-A
63/	X(8 cyl.)		1	C5DZ 3A611-A
61/63	S		1	C1SS 3A611-B
63/	X(6 cyl.)		1	C3DZ 3A611-B
3614 RACE - STEERING WORM OUTER				
61/64	S		1	C2SZ 3614-A
3-3618 RING - POWER STEERING PUMP VALVE OUTLET FITTING				
62/	B, X		1	LA 33618-A
3623 CAP ASSY. - STEERING WHEEL HUB - Also refer to Group 3649				
62	A (65B, 76B)		1	C2AZ 3623-A
60	S(with power steering)		1	C0SS 3623-B
61/63	S		1	C1SS 3623-C
64	S	Aztec Gold	1	C4SZ 3623-J
64	S	Blue	1	C4SZ 3623-K
64	S	Golden Beige	1	C4SZ 3623-F
64	S	Palomino	1	C4SZ 3623-H
64	S	Rose Beige	1	C4SZ 3623-G
64	S	Silver Blue	1	C4SZ 3623-E
64	S	Turquoise	1	C4SZ 3623-L
64	S	White Pearl	1	C4SZ 3623-C
64/	S	Black crinkle	1	C5SZ 3623-A
64/	S	Red crinkle	1	C6SZ 3623-F
3C626 SPACER - POWER STEERING CYLINDER MOUNTING BRACKET				
63	X(8 cyl.)	Cut from .040" thick steel-4.94" long	1	*C3DA 3C626-A
3D626 BRACKET ASSY. - STEERING COLUMN & INSTRUMENT PANEL COVER PIVOT				
64	S		1	C4SZ 3D626-A
3-3627 RETAINER - POWER STEERING PUMP RELIEF VALVE - Also refer to Group 3C742				
60/	A, S	Plug	1	B8E 33627-A
62	B		1	
3629 RETAINER - HORN RING				
62	B (62C)	Steering wheel hub emblem	1	C2OZ 3629-A
63	B (65A)		1	
60	S		1	B8S 3629-A
3B629 REINFORCEMENT - FLEXIBLE COUPLING STEERING				
63/64	A		2	C3AZ 3B629-A
3630 PLATE - HORN RING CONTACT				
60	S		1	B8S 3630-A
60	S	Screw (plate to ring)-No. 6-32 x 1/2"	3	51763-S8(U362)
		Bushing (screw)		B2TZ 4108-A

YEAR	MODEL	DESCRIPTION	QTY.	PART NUMBER
3A633 KIT - POWER STEERING INSTALLATION - COMPLETE				
60	A(8 cyl. 292)	Not replaced (8-68)	1	★COAZ 3A633-B
Consists of the following				
1	B5A 2344-A	Clamp-hose	1	B8AZ 6A312-B Pulley-crankshaft
1	C1AA 3304-A	Rod-steering to idler	1	COAZ 8620-A Belt-V-drive
1	B2A 3332-A	Seal-steering	1	B8A 33554-B Bracket-pump adj.
2	8M 3332	Seal-steering	1	B8A 33559-A Bracket-pump
1	COAA 3350-C	Bracket-idler mounting	5	20408-S7 Bolt-3/8"-16 x 1 1/8"
1	COAZ 3352-B	Kit-idler arm & bushing	2	20428-S8 Bolt-3/8"-16 x 1 1/4"
1	COAA 3A540-B	Cylinder	2	20429-S8 Bolt-3/8"-24 x 1 1/4"
1	B8A 3562-B	Bracket-pump support	2	20469-S8 Bolt-3/8"-24 x 1 1/2"
1	COAA 3A575-B	Tube-return to control valve	1	21063-S8 Bolt-9/16"-18 x 2.00"
1	B3AZ 3C589-A	Kit-cylinder end mounting bushing	1	33799-S7 Nut-hex. hd. -3/8"-16
1	COAA 3590-C	Arm-steering sector shaft	10	34807-S Lockwasher-3/8"
1	B7AZ 3C590-A	Kit-piston rod end bushing	1	34850-S Lockwasher-9/16"
1	B8AZ 3A609-A	Insulator-hose	3	39883-S7 Screw-5/16"-18 x 1 1/2"
1	COAA 3A610-A	Retainer-hose insulator	1	45565-S8 Bolt-3/8"-24 x 4"
1	COAA 3A611-A	Bracket-hose insulator	1	45592-S Bolt-5/16"-18 x 4 1/2"
◆1	B9AZ 3A691-C	Pump, reservoir & pulley assy.	1	351059-S Nut-castle-1/2"-20
◆1	COAA 3A691-C	Pump, reservoir & pulley assy.	3	352981-S Washer-flat-3/8"
1	COAZ 3A713-A	Hose-return line	2	353992-S Washer-flat-3/8"
1	COAA 3A714-A	Tube-control valve to cylinder	1	354193-S Washer-flat-3/8"
1	COAA 3A717-A	Tube-control valve to cylinder end	1	359098-S Washer-flat-3/8"
1	COAZ 3A719-A	Hose-pressure line	1	370851-S8 Bolt-5/8"-18 x 1 1/8"
1	COAA 3A730-D	Valve-control	2	372093-S Nut-rivet-3/8"-16
60	S(8 cyl. 430)-with A/C		1	COSZ 3A633-C
Consists of the following				
2	B6A 2265-BB	Hose	1	20468-S8 Bolt-3/8"-16 x 1 1/2"
1	B5A 2344-A	Clamp-hose	2	20469-S8 Bolt-3/8"-24 x 1 1/2"
1	B9SS 3304-A	Rod-steering arm to idler	5	33799-S7 Nut-hex. hd. -3/8"-16
1	B8S 3351-A	Bracket-idler arm	3	33800-S8 Nut-hex. hd. -3/8"-24
1	B4A 3552-B	Kit-idler arm & bushing	1	33925-S7 Nut-jam-3/8"-24
1	COSS 3A540-A	Cylinder	2	34032-S7 Nut-castle-1/2"-20
1	B3AZ 3C589-A	Kit-cylinder end mounting bushing	5	34807-S8 Lockwasher-3/8"
1	B8E 3590-C	Arm-sector shaft	2	34808-S8 Lockwasher-7/16"
1	B7AZ 3C590-A	Kit-piston rod end bushing	2	34847-S8 Lockwasher-3/8"
1	B8AZ 3A610-A	Retainer-hose insulator	2	34920-S7 Lockwasher-3/8"
1	COSS 3623-B	Cap-wheel hub	4	40156-S8 Screw-tap. -5/16"-18 x 5/8"
1	COSS 3A691-H	Pump-reservoir & pulley assy.	1	44726-S8 Washer-flat-3/8"
1	COSS 3A713-A	Hose-return line	1	45218-S Nut-pal-3/8"-24
1	COSS 3A714-B	Tube-control valve to cyl.	2	45565-S8 Bolt-3/8"-24 x 4"
1	COSS 3A717-B	Tube-control valve to cyl. rod end	1	72035-S7 Pin-cotter-1/8" x 1.00"
1	COAA 3A730-D	Valve-control	1	87907-S8 Fitting-grease-1/4"-28
1	B8AZ 6A312-C	Pulley-crankshaft	1	87924-S8 Fitting-grease-1/4"-28
1	COAE 8620-A	Belt-V-drive	2	351059-S Nut-castle-1/2"-20
1	B8A 33550-A	Insulator-hose	1	351385-S7 Washer-flat-3/8"
1	B8S 33838-A	Bracket	1	352146-S Pin-roll-1/8" x 7/8"
3	20328-S	Bolt-3/8"-16 x 5/8"	1	352981-S Washer-flat-3/8"
2	20390-S8	Bolt-7/16"-14 x 1.00"	1	357629-S7 Lockwasher-11/32"
2	20408-S7	Bolt-3/8"-16 x 1 1/8"		
3B633-34 PLATE - STEERING COLUMN OPENING COVER				
63	A	Lower-movable column	1	C3AZ 3B634-A
64	A(Automatic Transmission)	Movable column	1	C4AZ 3B634-A
63/	A	Screw (plate to dash panel)-No. 14 x 5/8"	5	31498-S8(U253B)
3-3633 PIN - POWER STEERING PUMP ROTOR SHAFT				
60/	A, B, S, X	Eaton pump	1	LA 33633-A
3C636 SEAL - POWER STEERING CYLINDER STUD - Also refer to Group 3332				
63/	A	41/64" I. D. -1" long	1	C3AZ 3C636-A
63/	X	1 7/16" I. D. -2 3/32" long	1	C3DZ 3C636-A
64/	B		1	

◆ - Optional

YEAR	MODEL	DESCRIPTION	QTY.	PART NUMBER
3-3638 WASHER - POWER STEERING PUMP ADJUSTING BRACKET				
63/	A(8 cyl. 352, 390)-without A/C	35/64" I.D. - 1 1/16" O.D. - 1/16" thick	6	B4Q 33638-B
64/	S(with A/C)		5 or 6	
3-3640 INSULATOR ASSY. - POWER STEERING PUMP				
63	A(8 cyl. 352, 390)-without A/C	25/64" I.D. - 3/4" O.D. - 25/32" long	3	EAD 33640-A
64	A (8 cyl. 352, 390)		3	
64/	S(with A/C)		3	
3641 BOLT - STEERING COLUMN TUBE FLANGE TO TUBE				
60/	B, S, X	1/4"-28 x 3/4"	2	8M 3641-B
62	A (65B, 76B)		2	
63/	A		2	
60/	B, S, X	Nut-1/4"-28	2	351754-S33 (MM167)
62	A (65B, 76B)		2	
63/	A		2	
3A642 GASKET - POWER STEERING OIL RESERVOIR COVER				
60/64	A (8 cyl.)	5 29/64" O.D.	1	COAA 3A642-B
60	S		1	
61/64	S (without A/C)		1	
62	B (8 cyl.)		1	
63/64	B		1	
63/64	X (without A/C)		1	
60/64	A (6 cyl.)	4 5/32" O.D.	1	COAA 3A642-C
61/64	S (with A/C)		1	
62	B (6 cyl.)		1	
63/64	B, X (8 cyl.)-with A/C		1	
60	A, S	1 1/4" O.D. -use with wing nut	1	COAA 3A642-A
62/64	S		1	
62/64	B, X (8 cyl.)-with A/C		1	
3B642 BUSHING - MOVABLE STEERING COLUMN LOCKING LEVER PIVOT				
61/	S		1	C1SS 3B642-B
3A643 HOUSING ASSY. - POWER STEERING PUMP				
60/	A, B, S, X		1	C2SZ 3A643-A
60/	A, B, S, X	Seal (cover)-2 5/8" I.D.	1	87147-S91(T38)
3B644 BUTTON - MOVABLE STEERING COLUMN TO TRACK				
63/64	A(with Automatic trans.)		2	C3AZ 3B644-A
64/	S		1	
61/63	S		4	C1SS 3B644-B
3647 KIT - STEERING WORM BALL				
60/	A(exc. integral P/S)	Consists of 60 balls -.28125" dia. balls	1	B8A 3647-B
60	X (Saginaw)		1	
62/	B(except P/S)		1	
60	S		1	
61/64	S			
60/	B, X	Consists of 62 C5AR 3647-G balls-.25" diameter	1	C5AZ 3647-A
62	B (with P/S)		1	C0DR 3647-A
3B648 BEARING - STEERING COLUMN PILOT				
61/63	S	Nylon	1	C1SS 3B648-B
3649 EMBLEM - STEERING WHEEL HUB - Also refer to Group 3623				
62	B(62C)		1	C2OZ 3649-C
63	B(65B)		1	
62/64	B (Fairlane "500")-with horn ring		1	C2OZ 3649-A
61/63	S		1	C1SS 3649-B
64/	S		1	C4SZ 3649-A
60/	X (with Horn Ring) -except Sprint models		1	C0DF 3649-B
3B649 BRACKET - MOVABLE STEERING COLUMN LOCKING ACTUATOR				
63	A		1	C3AZ 3B649-B
64	A(except S/T)		1	C4AZ 3B649-A
64/	S		1	
61/63	S		1	C1SS 3B649-A
61/	A, S	Screw & washer (bracket to transmission control selector)-No. 10-32 x 3/8"	3	42802-S8(U33)
			Washer-flat-No. 10	
63	A	Set screw (column lock)-5/16"-18 x 1.55"	1	377952-S2(UU26F)
		Nut-5/16"-18		34056-S8(M160)

FORD CAR PARTS

SECTION 36

YEAR	MODEL	DESCRIPTION	QTY.	PART NUMBER
3A650 KIT - POWER STEERING CONTROL VALVE REPAIR				
60	A, S	Consists of 1-AJ 33706-A Bushing 1-AJ 33703-A Seal 1-4146882 Bushing 1-4146881 Seal	1	B9AZ 3A650-A
61/62	A, B, S, X		1	C2AZ 3A650-B
Consists of				
	2-B4A 2428-A Ring	1-B9MM 33697-B Seal	1-C7OZ 3A729-A	Cover
	1-C2AA 3C513-A Seal	1-C2AZ 3C706-A Ring	1-C1AA 3A740-B	Gasket
	1-C2OA 3C513-A Seal	1-C2AZ 3A728-A Clamp	2-32873-S7	Screw
63/64	A		1	C3AZ 3A650-B
63/	B, X		1	
Consists of				
	2-B4A 2428-A "O" ring	1-C2AZ 3A728-A Clamp	1-C1AA 3A740-C	Gasket
	2-C2OA 3C513-A Seal	1-C7OZ 3A729-A Cover	2-32873-S7	Screw
	2-C2OZ 3A519-B Bushing			
3B650 PIVOT ASSY. - MOVABLE STEERING COLUMN				
63	A(with F/M/2 & C/M)		1	C3AZ 3B650-A
64	A		1	C4AZ 3B650-A
63	S		1	C3SZ 3B650-A
64	S		1	C4SZ 3B650-A
63	A(with F/M/2 & C/M)	Screw (pivot to flange)-5/16"-18 x 1/2" lock	3	376976-S7-8 (BB574M)
61/	A, S	Nut(pivot to trans.control selector)-5/16"-18	1	33797-S7(M50)
		Washer-flat-5/16"	1	44725-S8(X22)
3C651 KIT - POWER STEERING PISTON BOOT and INSULATOR				
60/62	A		1	C1AZ 3C651-A
62/63	B		1	
Consists of				
	2-C1AA 3A344-A Insulator	2-C3AA 3A345-A Washer	1-C1AA 3C528-B	Boot
63/64	A		1	C3AZ 3C651-A
63/	X		1	
64/	B		1	
Consists of				
	2-C1AA 3A344-A Washer	2-C3AA 3A345-A Insulator	1-C3AA 3C528-A	Boot
		1-C3AZ 3C755-A Clamp		
3A652 BRACKET - POWER STEERING CYLINDER MOUNTING				
61/62	A		1	C1AA 3A652-B
63/	A		1	C3AZ 3A652-A
62/	B, X		1	C2OZ 3A652-A
63	X(8 cyl.)		1	C3DZ 3A652-A
61/62	A	Bolt (bracket to frame)-3/8"-24 x 4 1/4"	1	373835-S8 (BB496C)
61/	A	Bolt (bracket to frame)-3/8"-16 x 1 1/2"	1	376058-S(BB157A)
62/	B	Bolt (bracket to underbody)	1or2	
63	X		1or2	
63	A	Bolt (bracket to frame)-3/8"-24 x 1 1/8"	1	350634-S(BB216)
62/	B	Bolt (bracket to underbody)-3/8"-24 x 3 1/2"	1	45549-S(B179)
64	X (6 cyl.)		1	
63	X	Bolt (bracket to underbody)-3/8"-16 x 3 1/4"	1	354580-S(BB167)
61/	A	Nut-3/8"-16-rivet type	2	375750-S8(MM120)
62/	B	Nut-3/8"-16-rivet type	2	375474-S8 (MM120B)
63/	X		1	377605-S7-8 (MM151G)
62/	A	Nut (bracket to frame)-3/8"-16	1	
62/	B, X	Nut (bracket to underbody)	1	
		Nut-3/8"-24	1	382832-S100 (MM169JF)
		Lockwasher-3/8"	3	34807-S8(X66)
62/	B	Washer-flat-3/8"	1	353992-S(XX127)
62/	A		5	
63/	X		3	
62	A	Washer-flat-1/2"	1	356474-S18(XX183)
63	A	Washer-flat-7/16"	2	44730-S8(X26)

YEAR	MODEL	DESCRIPTION	QTY.	PART NUMBER
3B653 INSULATOR - MOVABLE STEERING COLUMN PIVOT				
62/63	S	"From 4/13/62"	1	C2SZ 3B653-A
63/	A		1	
64/	S		1	C4SZ 3B653-A
3B654 BUSHING - MOVABLE STEERING COLUMN PIVOT				
61/62	S	"Before 4/13/62" 7/16" I. D. -1/2" long-Nylon	2	C1SZ 3B654-B
64/	S		2	
62/63	S	"From 4/13/62" 7/16" I. D. -21/64" long-Nylon	2	C2SZ 3B654-A
63/	A		2	
3657 RETAINER - STEERING WHEEL HUB CAP				
61/64	S		1	C1SS 3657-C
3A657 KIT - STEERING SECTOR SHAFT ADJUSTING SHIM				
60/	A, B, X	Consists of 4 shims	1	B8AZ 3A657-A
60/64	S		1	
60	X (with Saginaw steering gear)	Thrust washer	1	
3A658 SPACER - POWER STEERING CONTROL VALVE SPOOL - SLEEVE END BUSHING				
61/64	A		1	C1AA 3A658-A
63/	B, X		1	
61/	A, B, X	Washer-flat (spacer retainer)-5/8"	1	370232-S(XX207)
3B658 PLATE - MOVABLE STEERING COLUMN LOCKING				
63	S		1	C3SZ 3B658-A
3B659 BRACKET ASSY. - MOVABLE STEERING COLUMN TO TRACK - LOWER				
63	A		1	C3AZ 3B659-B
61/63	S		1	C1SS 3B659-C
61/63	S	Bolt (bracket to transmission control selector)-5/16"-18 x 5/8"	2	373638-S7-8 (BB817F)
		Nut-5/16"-18		33797-S7 (M50)
3660 INSERT - STEERING WHEEL HUB CAP RETAINER				
62	B(62C)	1 19/32" O. D.	1	C2OZ 3660-A
63	B(65B)		1	
61/64	S	2 3/16" O. D.	1	C1SS 3660-B
3C660 WASHER - STEERING SHAFT COUPLING BOLT				
61/	A, B, S, X	19/64" I. D. & 25/64" I. D. -5/8" O. D.	AR	C3OZ 3C660-A
3B661 LEVER ASSY. - MOVABLE STEERING COLUMN LOCKING				
63	A		1	C3AZ 3B661-B
64/	A		1	C4AZ 3B661-A
61/63	S		1	C1SS 3B661-E
64/	S		1	C4SZ 3B661-A
63/	A	Stud (lever to track)-5/16"-18 x 3/8"-16 x 3 25/64" hex. shoulder	1	378212-S2(WW121)
64/	S	Stud (to track)-3/8"-16 & 5/16"-18 x 2.36"	1	378972-S2(WW124)
		Nut-3/8"-16		34057-S8(M161)
		Lockwasher-3/8"		34807-S8(X66)
		Washer-flat-33/64"		371703-S(XX179)
		Washer-spring-33/64"		356460-S8(XX369)
3B664 SPRING - MOVABLE STEERING COLUMN TRACK LOCKING				
63/	A	Lever-1 11/16" long-10 1/2 coils	1	C3AZ 3B664-A
64/	S		1	
61/63	S	1 13/16" long-13 coils	2	C1SS 3B664-B
3B666 BRACKET - MOVABLE STEERING COLUMN TRACK STOP				
61/63	S		1	C2SZ 3B666-A
61/63	S	Bolt (bracket to track)-5/16"-24 x 3/4"-shoulder	1	350756-S8(BB697)
61/63	S	Bolt (bracket to track)-5/16"-18 x 7/8"-square neck	1	373629-S7-8 (BB688C)
		Nut-5/16"-18		33797-S7 (M50)
		Washer-flat-5/16"		44722-S8(X19)
3668 CLAMP - STEERING COLUMN TO INSTRUMENT PANEL				
60/	X	Clamp Assy.	1	C0DF 3668-BP
60/	X	Nut (clamp to pedal support)-5/16"-24	2	33798-S8(M62)
		Lockwasher-5/16"		34806-S7(X64)

YEAR	MODEL	DESCRIPTION	QTY.	PART NUMBER
3B669 SHAFT & TORSION BAR ASSY. - POWER STEERING GEAR INPUT				
64	S	Pink paint at end of bar	1	C3VY 3B669-A
62/64	S	With side arm clamp type coupling	1	
61	S	Pin (shaft)-3/16" x 1 1/8"-spring	1	305086-S(NN108A)
3B669 KIT - TORSION BAR ASSY. and SLEEVE BEARING				
61/63	S (with pin lock type coupling & short shaft)	Consists of 1-C2SZ 3B669-K Bar 1-C2SZ 3B673-A Bearing	1	C2SZ 3B669-M
3670 ADAPTOR ASSY. - POWER STEERING PUMP TO RESERVOIR - Also refer to Group 3B726				
63	A(8 cyl. 260, 289)-with A/C		1	C3AZ 3670-A
64	A(6 cyl.)-without A/C		1	
64	A(8 cyl. 289,352,390)-with H/D alternator & A/C		1	
63/	X (8 cyl.)-with A/C		1	
63	B (8 cyl.)-with A/C "Before 3/11/63"		1	
63	A(6 cyl. & 8 cyl. 352, 390)		1	C3AZ 3670-B
64	A(6 cyl. & 8 cyl. 352, 390)-with H/D alternator without A/C		1	
63/	B(8 cyl.)-with A/C "From 3/11/63"		1	C3OZ 3670-A
64	S(with A/C)	Reservoir inlet tube	1	C4SZ 3670-A
3A670 ADJUSTER ASSY. - STEERING WORM THRUST BEARING				
61	A	Use with C1MR 3504-C & D	1	C3AZ 3A670-A
62/	A		1	
62/	B		1	
60/	X		1	C3DZ 3A670-C
3B671 KIT - POWER STEERING SLEEVE, SHAFT and TORSION BAR ASSY.				
60/64	S	With side arm clamp type coupling- consists of - 1-C2VR 3B708-D Sleeve 1-C3VY3B669-A Shaft	1	C3VY 3B671-A
3672 INSULATOR - HORN BUTTON				
60	S		1	B8S 3672-A
3673 INSULATOR - HORN RING				
60/61	A		3	B5A 3673-A
60	S		1	B8S 3673-A
3A673 COVER - STEERING COLUMN OPENING or NEUTRAL SWITCH				
60	A (with C/M)	Opening	1	C1AF 3A673-AP
60/62	A (with F/M/2)		1	
60/62	A (with S/T)	Opening	1	C1AF 3A673-BP
61/62	A(with C/M)-except 65B, 76B	Opening	1	C2AZ 3A673-A
63	A (moveable column)	Opening	1	C3AZ 3A673-B
64	A(moveable column) NOTE 1	Opening	1	C4AZ 3A673-A
60/	A	Screw (cover to instrument panel)-No. 8- 15 x 3/4"-oval head-self-tapping	2	52360-S13(U294)
		Spring-nut-No. 8		353464-S8(MM248)
3B673 BEARING ASSY. - POWER STEERING CONTROL VALVE SLEEVE				
60/64	S	Double row input shaft ball bearing	1	C2SZ 3B673-A
61/64	S		1	C1VR 3B673-A
3674 INSULATOR - STEERING COLUMN LOWER FLANGE - Also refer to Group 3B564				
60	A		1	B9A 3674-A
3A674 PUMP ASSY. - POWER STEERING				
61/64	A (8 cyl. 352, 390)	Less reservoir & pulley	1	C2AZ 3A674-A
61/62	A (8 cyl. 289, 292)	Eaton-less reservoir & pulley	1	C2AZ 3A674-B
61/	A (6 cyl.)		1	
60	A (6 cyl. & 8 cyl. 292, 352)		1	
62/64	B, X(6 cyl.)		1	
62/63	B(8 cyl.)-with A/C		1	
60	S		1	
63	A, B, X(8 cyl. 260, 289)-without A/C	Eaton-less reservoir & pulley	1	C3AZ 3A674-A
64	A(8 cyl. 289)-without A/C	Eaton-less reservoir & pulley	1	C4AZ 3A674-A
64	B, X(8 cyl.)		1	
62/64	S	Less reservoir & pulley	1	C3SZ 3A674-A
3B674 COVER - MOVEABLE STEERING COLUMN OPENING				
61/	S		1	C1SS 3B674-A

NOTE 1 - For fixed column cover refer to Body Group 01698-9

YEAR	MODEL	DESCRIPTION	QTY.	PART NUMBER
3A675 KIT - POWER STEERING CONTROL VALVE CENTERING SPRING				
60	A, S	Consists of 1-353618-S100 Nut 1-AJ 33704-A Spring 1-353622-S100 Washer 1-AJ 33712-A Plate 1-AJ 33707-A Spacer 2-AJ 3799-A Washer	1	B9AZ 3A675-A
61/62	A	Consists of 1-C1AA 3A594-A Spring 1-AJ 33707-B Spacer 2-B9M 3799-A Washer 2-372300-S Washer	1	C1AZ 3A675-A
63/64	A	Consists of 1-C3AA 3A594-A Spring 1-AJ 33707-B Spacer 1-C2AZ 3C706-A Ring 2-B9M 3799-A Washer 2-372300-S Washer	1	C3AZ 3A675-A
64	B	Consists of 1-C3DA 3A594-A Spring 1-AJ 33707-B Spacer 1-C2AZ 3C706-A Seal 2-B9M 3799-A Washer 2-372300-S Washer	1	C3OZ 3A675-A
63/64	X	Consists of 1-C3DA 3A594-B Spring 1-AJ 33707-B Spacer 1-C2AZ 3C706-A Seal 2-B9M 3799-A Washer 2-372300-S Washer	1	C3DZ 3A675-A
62/63	B		1	
3C675 GASKET - POWER STEERING OIL RESERVOIR FILLER CAP				
61/	A(8 cyl.)		1	C1AA 3C675-A
63/	X		1	
3676-8 BRACKET - STEERING COLUMN TO INSTRUMENT PANEL				
63	A(fixed column)		1	C3AZ 3678-A
63	A(moveable column)-with F/M/2 & C/M	Column to track-upper	1	C3AZ 3678-B
64	A(fixed column)		1	C4AZ 3678-A
64/	A(moveable column)	Column to track-upper	1	C4AZ 3678-B
62/	B		1	C2OZ 3678-B
64/	S	Column to track-upper	1	C4SZ 3678-A
60/	X		1	CODF 3676-AP
60/	A	Bolt (brkt. to instrument panel)-5/16"-24 x 1 1/4"	2	20427-S8(B158)
61/	A	Bolt (bracket to cover plate)-5/16"-18 x 3/4"	2	20346-S8(B50)
60	S	Screw (bracket to pedal support bracket) 5/16"-24 x 3"	2	351757-S8(BB30)
61	S (fixed column)	Bolt (bracket to instrument panel)-3/8"-16 x 1 1/8"	6	371186-S(BB441)
61	S (fixed column)	Screw (upper bracket to trans. control selector)- 5/16"-18 x 3/4"-washer head	2	359662-S7-8 (BB575A)
		Locknut-5/16"-18		34392-S7(M93)
		Nut-5/16"-24		33798-S7-8(M62)
		Lockwasher-5/16"		34806-S7(X64)
		Lockwasher-5/16"-external tooth		34941-S7
		Washer-flat-5/16"		44722-S8(X19)
3C677 SUPPORT - POWER STEERING OIL RESERVOIR FILTER ELEMENT				
62/	S(without A/C)	"From 5/1/62"	1	B8SZ 3C677-A
62/	A, B	"From 5/1/62"	1	
63/	X		1	
62/	S(with A/C)	"From 5/1/62"	1	C2SZ 3C677-A
3C680 INSERT - STEERING WHEEL TRIM				
60	S		3	B8SZ 3C680-A
3685 KEY - IGNITION and DOOR LOCK - BLANK				
60/64	A, B, S, X		1	B9A 3685-A
3B688 SPRING - POWER STEERING OIL RESERVOIR FILTER ELEMENT RETAINING				
62/	A, (B without A/C)	"From 5/1/62"	1	C2SZ 3B688-A
62/64	S(without A/C)	"From 6/1/62"	1	
63/	X(without A/C)		1	
62/64	B(8 cyl.)-with A/C	"From 5/1/62"	1	C2SZ 3B688-B
62	A(6 cyl. & 8 cyl. 260)-with A/C		1	
62/64	S(with A/C)	"From 6/1/62"	1	
63/	X(8 cyl.)-with A/C		1	
62	S(without A/C)	"Before 6/1/62"	1	B8AZ 3B688-A

YEAR	MODEL	DESCRIPTION	QTY.	PART NUMBER
3689 LOCK CYLINDER and KEYS - GLOVE and LUGGAGE COMPARTMENT, TAIL GATE, LIFT GATE or BACK DOOR				
60	A(except 59, 71)		1	B9A 3689-A
63/64	A(71)-manual		1	
61	A		1	
60	A(59, 71)		1	B9A 3689-B
60	S(76A)		1	B9S 3689-A
		For Balance of Lock Sets - Refer to Appropriate Chassis & Body Groups		
3691 HOSE - POWER STEERING RESERVOIR TO PUMP				
60	A-6 cyl.	13 7/8" long-make from B9C 3691-A	1	★C0AA 3691-A
61/62	A-6 cyl. (with A/C)	14 5/8" long-make from B9C 3691-A	1	★C1AA 3691-A
63/	A (6 cyl.)	15 5/8" long	1	C3AZ 3691-A
63/	A (8 cyl. 352, 390), B(8 cyl.)-with A/C	11 1/4" long-make from C3AZ 3691-A	1	★C3AA 3691-G
63/	A(8 cyl. 260, 289)-with A/C	13 1/4" long-make from C3AZ 3691-A	1	★C3AA 3691-H
64	A(8 cyl. 352, 390)-with A/C	12 1/8" long-make from C3AZ 3691-A	1	★C4AA 3691-A
62	B (with A/C)	7 3/8" long-make from B3T 4090-B	1	★C2OA 3691-A
61/62	S(with A/C)	"Before 6/1/62" 1/2" I.D. -11 5/8" long-cut from B9C 3691-A	1	★C1SS 3691-B
62/63	S(with A/C)	"From 6/1/62" 3/4" I.D. -10 5/8" long	1	C2SZ 3691-A
64	S	9 1/4" long-make from C2SZ 3691-A	1	★C3AA 3691-D
63/	X(8 cyl.)-with A/C	8 1/8" long-make from C2SZ 3691-A	1	★C3DA 3691-A
3A691 PUMP, RESERVOIR & PULLEY ASSY. - POWER STEERING -Replaced by details (3A674, 3A697, 3A732, 3A733) -except as listed below				
61/62	A(8 cyl. 292)-with A/C		1	C2AZ 3A691-F
63	A(8 cyl. 260, 289)-without A/C		1	C3AZ 3A691-B
62/	B(6 cyl.)		1	C2OZ 3A691-E
63	B(8 cyl.)-without A/C		1	C3AZ 3A691-A
63	S (without A/C)		1	C3SZ 3A691-A
63/64	X(8 cyl.)-without A/C	"Before 1/6/64"	1	C3DZ 3A691-A
64	X(6 cyl.)-without A/C	"Before 3/2/64"	1	★C4DZ 3A691-B
64	X(6 cyl.)-with A/C	"From 3/2/64"	1	
60	S(8 cyl. 430)	Nut (pump to adjusting bracket)-3/8"-16	2	33799-S7(M52)
		Lockwasher-3/8" internal tooth		★34920-S7
		Washer-flat-3/8"		351385-S8(XX158)
3A696 PUMP and PULLEY ASSY. - POWER STEERING - Replaced by details (3A674 & 3A733)-except as listed below				
63	A(8 cyl. 352, 390)-without A/C		1	C3AZ 3A696-C
61/62	S(with A/C)		1	C2SZ 3A696-C
63	S(with A/C)		1	C3SZ 3A696-A
3A697 RESERVOIR ASSY. - POWER STEERING OIL - Also refer to Group 3A699				
60/62	A, S(8 cyl.)	Includes outlet tube	1	C2AZ 3A697-B
64	A(8 cyl. 352, 390)		1	
62	B (8 cyl.)		1	
63	A (8 cyl.)	"Before 11/15/62" Includes outlet tube	1	C3AZ 3A697-E
64	A (8 cyl. 352, 390)-with A/C or H/D alternator		1	C4AZ 3A697-B
63/	X(8 cyl.)-with A/C		1	
64	A(6 cyl.)-without A/C		1	C5ZZ 3A697-A
64	A(8 cyl. 289)-with A/C		1	
62	B(8 cyl.)-with A/C	Includes outlet tube-Not replaced	1	★C2OZ 3A697-B
63/	B, X (6 & 8 cyl.)-without A/C	Includes outlet tube	1	C3OZ 3A697-A
63/	A (8 cyl. 260, 289)-without A/C		1	
63/	B(8 cyl.)-with A/C	Includes outlet tube & bracket	1	C3OZ 3A697-C
64	X(8 cyl.)-with A/C		1	
61/64	S(with A/C)		1	C4SZ 3A697-B
60/	A	Bolt (Reservoir to fender apron)-5/16"-24 x 3/4"	2	20347-S8(B156)
61/64	S with A/C	"Before 9/18/63"	2	
63/	X(8 cyl.)-with A/C	Bolt (reservoir to fender apron)-5/16"-24 x 1"	2	20387-S8(B157)
60/	A(6 cyl.)	Locknut-5/16"-24	2	34443-S7-8(M79)
63/	X(8 cyl.)-with A/C		2	
61/63	S(with A/C)	Locknut-5/16-24		354299-S2(MM156)
62/	B(8 cyl.)-with A/C	Screw (reservoir to fender apron)-5/16"-18 x 1/2" tapping	2	40923-S8(U264)
64	S(with A/C)	"From 9/18/63" Bolt (to fender apron)-1/4"-20 x 7/8"	2	370519-S(BB125)
		Lockwasher-1/4"		351274-S7(XX298)

YEAR	MODEL	DESCRIPTION	QTY.	PART NUMBER
3C697 SPRING - POWER STEERING HOSE				
62/	B		1	C2OZ 3C697-A
3A698 COVER ASSY. - POWER STEERING PUMP HOUSING				
63/64	B, X		1	C3OZ 3A698-A
60	S (8 cyl. 430)		1	
60	S (8 cyl. 352)		1	C0AA 3A698-A
60/	A		1	
62	B		1	
61/	S		1	B9MM 3A698-A
62/	S	Pin (cover to housing)-5/16" x 3/4"	2	357648-S8(NN55)
60/62	A (1930/61 S)	Bolt (cover to housing)-3/8"-16 x 2"	2or3	20522-S8(B89)
63/	B, X(6 & 8 cyl.)	Bolt (cover to housing)-3/8"-16 x 2 1/8"	1	370967-S(BB158)
63/	B (8 cyl.)	Bolt (cover to housing)-3/8"-16 x 3 3/4"	1	377957-S7-8
63/	X(8 cyl.)		2	(BB169A)
60/	A, B, S, X	Seal (cover)-2 5/8" I.D.	1	87147-S92(T38)
3-3698 BOLT - POWER STEERING CONTROL VALVE SPOOL				
60/	A (1960 S)	5/16"-24-overall length 5 1/16"	1	AC 33698-A
62/	B, X		1	
63/	X	Nut-5/16"-24	1	353618-S100 (MM141)
60/	A, B (1960 S)	Locknut-5/16"-24		34443-S7-8(M79)
		Washer-flat-5/16"		44722-S8(X19)
60/	A (1960 S)	Pin-straight (bolt retainer)-1/8" x 1"	1	370235-S(NN102)
62/	B, X		1	
3A699 BODY ASSY. - POWER STEERING OIL RESERVOIR - Also refer to Group 3A697				
63/	A(6 & 8 cyl.)-fender mounted	Includes outlet tube & bracket	1	C3AZ 3A699-A
61/	S		1	C2SZ 3A699-B
60/	A, B, S, X	Pin (cam to pump rod)-1/8" x 1/4"	1	370903-S(NN53)
60/	A	Gasket (valve)-rubber-1/4" I. D.	1	372144-S(XX90)
3B699 SEAL - POWER STEERING CONTROL VALVE SPOOL ADJUSTER				
61/	S	1 7/32" O. D. -35/64" shaft diameter	1	C0LR 3B699-A
62	S	Inlet seat pressure-5/16" I. D. -Blue stripe	1	C2AZ 3B699-A
3A700 ORIFICE - POWER STEERING TUBE SEAT				
60/	B, X	3/8" tube	1	C0AA 3A700-A
60/64	A		1	
60	S		1	
61/	S		1	C1SS 3A700-A
3B700 ADJUSTER - POWER STEERING CONTROL VALVE SPOOL				
61/	S		1	C0LR 3B700-A
3B703 SPACER - STEERING COLUMN UPPER BEARING SPRING				
64	S		1	C4SZ 3B703-A
3C703 SPACER - STEERING GEAR HOUSING SEAL				
62/64	S	"From 6/1/62" 1.64" I. D. -1.74" O. D. -use between sector shaft seals	1	C2SZ 3C703-A
3C705 CAP - POWER STEERING CONTROL VALVE SPOOL CENTERING SPRING				
60	S		1	AC 33705-A
60/62	A	"Before 2/15/62"	1	
62/	A, B, X	"From 2/15/62"	1	C2AZ 3C705-A
60	S	Bolt (cap to adapter)-1/4"-20 x 1 1/2"	2	353620-S100
60/	A, B, X		2	(BB18)
		Lockwasher-1/4"		34805-S8 (X62)
3C705 KIT - P/S CONTROL VALVE SPOOL CENTERING SPRING CAP				
62/	A, B, X	Consists of (1) C2AZ 3C705-A cap (1) C2AZ 3C706-A "O" ring (1) B9M 33712-A plate (2) 358533-S screw & washer	1	C2AZ 3C705-B
3-3705 CAP - POWER STEERING CONTROL VALVE SPOOL CENTERING SPRING -Refer to Group 3C705				
3A706-7 STOP - STEERING ARM				
60/62	X	"Before 10/15/61"	1	C0DD 3A706-C
		R. H.	1	C0DD 3A707-C
		L. H.		
62/64	X (without P/S)	"From 10/15/61"	1	C2DZ 3A706-A
		R. H.	1	C2DZ 3A707-A
		L. H.		
64	X(6 cyl.)-with P/S		1	C3DZ 3A706-B
		R. H.	1	C3DZ 3A707-B
		L. H.		
61/	X	Nut (stop to arm)-7/16"-20	4	34671-S8(M67)

FORD CAR PARTS

SECTION 37

YEAR	MODEL	DESCRIPTION	QTY.	PART NUMBER
3C706 SEAL - POWER STEERING CONTROL VALVE SPOOL CENTERING SPRING CAP				
62/	A, B, X	"From 2/15/62"	1	C2AZ 3C706-A
3707 NUT - STEERING WORM THRUST BEARING				
60/	A, B, S		1	B8A 3707-A
60	X	Saginaw steering gear	1	
61/	X		1	C3DZ 3707-A
3708 CAP - POWER STEERING CONTROL VALVE SPOOL ADJUSTER				
61/64	S	1 1/4" O. D. - 1" - 20 thread	1	C3SZ 3708-A
61/64	S	Seal (Cap) - 7/8" I. D.	1	87022-S94(TTE)
3C708 WASHER - STEERING COLUMN SOCKET - THRUST				
63/64	A (with Automatic Trans.)		1	C3AZ 3C708-A
64	S		1	C4SZ 3C708-A
3B710 WIRE and TERMINAL - STEERING SHAFT GROUND				
63/64	A (moveable column)	4 29/32" long-cut from B6A 14296-C	1	★C3AA 3B710-A
63	S	"Before 4/8/63"	1	
63/	S	"From 4/8/63"	1	★C3SA 3B710-A
63/64	A	Retainer (wire)-1/4" spring	1	377938-S7-8(RR4)
3A711 KIT - POWER STEERING PUMP IMPELLER REPAIR				
60/	A, B, S, X	Use with Eaton roll type pump-consists of 1-C0AA 3B561-A Carrier 1-C0AA 3B585-A Insert 6-KD 33684-A Roller	1	B9MY 3A711-A
3-3712 PLATE - POWER STEERING CONTROL VALVE				
61/	A, B, X		1	B9M 33712-A
3A713 HOSE ASSY. - POWER STEERING RETURN LINE - Refer to Group 3A719				
3A714 HOSE ASSY. - POWER STEERING CONTROL VALVE TO CYLINDER - Refer to Group 3A719				
3C716 INSULATOR ASSY. - STEERING GEAR				
63/	S	7/16"-14-2 3/4" O. D.	3	C3SZ 3C716-B
3A717 TUBE ASSY. - POWER STEERING CONTROL VALVE TO CYLINDER - ROD END - Refer to Group 3A719				
3B718 SUPPORT ASSY. - STEERING COLUMN				
63	A	Retainer	1	C2UZ 3B718-A

3A719 POWER STEERING HOSE - APPLICATION CHART

All power steering hoses are listed under basic number 3A719. The description column indicates functions of the parts.

When hose assemblies are no longer available for service the detail parts must be used.

These are listed in assembly part number sequence beginning on page 89.

Also see assembly instructions and related illustrations beginning on page 91.

YEAR	MODEL	DESCRIPTION	APPROX. DEVEL. LENGTH (INCHES)	QTY.	PART NUMBER
- A -					
60	A-6 & 8 cyl.	Control valve to pump-return	30 1/4	1	C3AZ 3A713-C
	-6 & 8 cyl.	Valve to cylinder	21 1/4	1	C0AA 3A714-A
	-6 & 8 cyl.	Cylinder to valve	20 7/8	1	C0AA 3A717-A
	-6 cylinder	Pump to control valve-pressure	31	1	C0AZ 3A719-B
	-8 cylinder	Pump outlet tube to valve-pressure	27	1	C0AZ 3A719-A
	-8 cylinder	Pump outlet tube-pressure		1	AK 3394-A
61/62	A-6 & 8 cyl.	Control valve to pump-return	30 1/4	1	C3AZ 3A713-C
	-6 & 8 cyl.	Valve to cylinder	8 5/16	1	C1AA 3A714-A
	-6 & 8 cyl.	Cylinder to valve	8 5/16	1	C1AA 3A714-A
	-6 cylinder	Pump to control valve-pressure	36	1	C1AA 3A719-C
	-8 cylinder	Pump to control valve-pressure	34	1	C1AA 3A719-D

3A719 POWER STEERING HOSE - APPLICATION CHART - continued

YEAR	MODEL	DESCRIPTION	APPROX. LEVEL LENGTH (INCHES)	QTY.	PART NUMBER		
- A -							
63	A-6 & 8 cyl. -6 & 8 cyl. -6 & 8 cyl. -6 cylinder -8 cyl, 260, 289-w/A/C -8 cyl, 260, 289-w/o A/C -8 cyl, 352, 390	Control valve to pump-return	30 1/4	1	C3AZ 3A713-C		
		Valve to cylinder	8 1/4	1	C3AZ 3A714-A		
		Cylinder to valve	8 1/4	1	C3AZ 3A717-A		
		Pump to control valve-pressure	34	1	C3AZ 3A719-D		
		Pump to control valve-pressure	35	1	C3AZ 3A719-A		
		Pump to control valve-pressure	29	1	C4AZ 3A719-A		
		Pump to control valve-pressure	32	1	C3AZ 3A719-C		
64	A-6 cylinder -8 cyl, all exc, 289 -8 cyl, 289-w/A/C -8 cyl, 289-w/o A/C -8 cylinder -8 cylinder -8 cyl, 260, 289 -8 cyl, 352, 390-w/o A/C -8 cyl, 352, 390-w/A/C	Control valve to pump-return	30 1/4	1	C3AZ 3A713-C		
		Valve to cylinder	8 1/4	1	C3AZ 3A714-A		
		Cylinder to valve	8 1/4	1	C3AZ 3A717-A		
		Pump to control valve-pressure	34	1	C3AZ 3A719-D		
		Control valve to pump-return	30 1/4	1	C3AZ 3A713-C		
		Control valve to pump-return	36 3/4	1	C4AZ 3A713-A		
		Control valve to pump-return	27 5/8	1	C4AZ 3A713-B		
		Valve to cylinder	8 1/4	1	C3AZ 3A714-A		
		Cylinder to valve	8 1/4	1	C3AZ 3A717-A		
		Pump to control valve-pressure	29	1	C4AZ 3A719-A		
		Pump to control valve-pressure	32	1	C3AZ 3A719-C		
		Pump to control valve-pressure	31	1	C4AZ 3A719-B		
		- B -					
		62	B-6 cylinder -8 cyl, -w/A/C -w/o A/C	Control valve to pump-return	45	1	C2OZ 3A713-E
Valve to cylinder	8 7/16			1	C2OZ 3A714-A		
Cylinder to valve	9 1/8			1	C2OZ 3A719-A		
Pump to control valve-pressure	40			1	C2OZ 3A719-D		
Control valve to pump-return	49 3/4			1	C2OZ 3A713-F		
Control valve to pump-return	40			1	C2OZ 3A713-D		
Valve to cylinder	8 7/16			1	C2OZ 3A714-A		
Cylinder to valve	9 1/8			1	C2OZ 3A717-A		
Pump to control valve-pressure	41			1	C2OZ 3A719-C		
63	B-6 cylinder -8 cyl, -w/A/C -w/o A/C -w/A/C -8 cylinder-w/o A/C			Control valve to pump-return	47	1	C3OZ 3A713-B
		Valve to cylinder	8 7/16	1	C2OZ 3A714-A		
		Cylinder to valve	9 1/8	1	C2OZ 3A717-A		
		Pump to control valve-pressure	44 1/2	1	C3OZ 3A719-B		
		Control valve to pump-return	53 1/2	1	C3OZ 3A713-C		
		Control valve to pump-return	41 1/2	1	C3OZ 3A713-A		
		Valve to cylinder	8 7/16	1	C2OZ 3A719-A		
		Cylinder to valve	9 1/8	1	C2OZ 3A717-A		
		Pump to control valve-pressure	38	1	C3OZ 3A719-C		
		Pump to control valve-pressure	38 1/2	1	C3OZ 3A719-A		
		64	B-6 cylinder -8 cyl, -w/A/C -w/o A/C	Control valve to pump-return	47	1	C3OZ 3A713-B
Valve to cylinder	8 1/2			1	C3OZ 3A714-A		
Cylinder to valve	9 1/8			1	C3OZ 3A717-A		
Pump to control valve-pressure	44 1/2			1	C3OZ 3A719-B		
Control valve to pump-return	53 1/2			1	C3OZ 3A713-C		
Control valve to pump-return	41 1/2			1	C3OZ 3A713-A		
Valve to cylinder	8 1/2			1	C3OZ 3A714-A		
Cylinder to valve	9 1/8			1	C3OZ 3A717-A		
Pump to control valve-pressure	38 1/2			1	C3OZ 3A719-A		
- S -							
60	S	Control valve to pump-return	27	1	COSS 3A713-A		
		Control valve to cylinder	18 1/2	1	COSS 3A714-B		
		Cylinder to valve	18 1/2	1	COSS 3A717-B		
		From pump outlet tube to valve-pressure	25	1	B9SZ 3A719-A		
		Pump outlet tube-pressure		1	AK 3494-A		
61/62	S	From gear to pump-return	27	1	COSS 3A713-A		
		Pump to gear-pressure	30 1/2	1	C3SZ 3A719-A		

3A719 POWER STEERING HOSE - APPLICATION CHART - continued

YEAR	MODEL	DESCRIPTION	APPROX. DEVEL. LENGTH (INCHES)	QTY.	PART NUMBER
- S -					
63/	S	From w/s wiper motor tube to pump - return-cut to size-from B4C 4090-A bulk hose to fit from w/s wiper motor tube to reservoir or pump	AR	1	@ * 3A005
	1963	Pump to gear-pressure	30 1/2	1	C3SZ 3A719-A
	1964	Pump to gear-pressure	39 1/2	1	C4SZ 3A719-A
	1965	Pump to gear-pressure	39 1/2	1	C5SZ 3A719-B
	1965/66	From pump outlet tube to gear-pressure	28 1/2	1	C5SZ 3A719-A
		Pump outlet tube-pressure		1	C5SZ 3494-B
	- with Eaton pump				
	- with Ford pump				

- X -

63/64	X-6 cylinder	Control valve to pump-return	46 1/2	1	C3DZ 3A713-A
		Control valve to cylinder	9	1	C3DZ 3A714-A
		Cylinder to valve	9 1/2	1	C3DZ 3A717-A
		Pump to control valve-pressure	22	1	C3DZ 3A719-A
		Pump to control valve-pressure	40	1	C4DZ 3A719-A
	-8 cylinder	Control valve to pump-return	49	1	C3DZ 3A713-D
		Valve to cylinder	9 1/2	1	C3DZ 3A714-B
		Cylinder to valve	10	1	C3DZ 3A717-B
		Pump to control valve-pressure	54 1/1	1	C3DZ 3A719-B
	"Before 3/2/64"				
	"From 3/2/64"				

YEAR	MODEL	DESCRIPTION	QTY.	PART NUMBER
61/	A, S	Clamp-5/8" dia. -spring wire (3A713 hose to pump)	AR	97328-S35(E1C)
64	A(8 cyl. 352, 390)	Nut-7/16"-24 (3A719 hose to valve)	1	87943-S8(I-21)
64	A(8 cyl. 352, 390)	Nut-5/8"-18 (3A719 hose to pump)	1	87945-S8(I-23)

3A719 POWER STEERING HOSE - continued

INSTALLATION INSTRUCTIONS FOR REPLACING P/S HOSE ASSEMBLIES WITH UNIVERSAL FITTINGS

1. Keep old hose as a guide for length and shape.
2. Assemble new hose, using illustration on page 91 as a guide.
3. Fittings may be reused if rubber portion of hose subsequently requires replacement.

HOSE ASSEMBLY	REPLACED BY	
	BULK HOSE or TUBING - LENGTH IN INCHES	FITTINGS, ETC. (USE QUANTITY SHOWN)
C0SS 3A713-A	C7AZ 3A005-A(27)	None Required
C2OZ 3A713-D	C7AZ 3A005-A(32)	C7OZ 3A713-E (1), B5A 2344-A (1)
C2OZ 3A713-E	C7AZ 3A005-A(37)	C7OZ 3A713-E (1), B5A 2344-A (1)
C2OZ 3A713-F	C7AZ 3A005-A(42)	C7OZ 3A713-E (1), B5A 2344-A (1)
C3AZ 3A713-C	C7AZ 3A005-A(35), C7AZ 3A609-A(3)	C7AZ 3A713-H (1), C9AZ 8287-A
C3DZ 3A713-A	C7AZ 3A005-A(31)	C7SZ 3A713-B (1), B5A 2344-A (1)
C3DZ 3A713-D	C7AZ 3A005-A(39 1/2), C7AZ 3A609-A(3)	C7DZ 3A713-B (1), B5A 2344-A (1)
C3OZ 3A713-A	C7AZ 3A005-A(31)	C7OZ 3A713-D (1), B5A 2344-A (1)
C3OZ 3A713-B	C7AZ 3A005-A(37)	C7OZ 3A713-D (1), B5A 2344-A (1)
C3OZ 3A713-C	C7AZ 3A005-A(42)	C7OZ 3A713-D (1), B5A 2344-A (1)
C4AZ 3A713-A	C7AZ 3A005-A(37)	C7AZ 3A713-G (1), B5A 2344-A (1)
C4AZ 3A713-B	C7AZ 3A005-A(27 1/2)	C7AZ 3A713-G (1), B5A 2344-A (1)
C0AA 3A714-A	C7AZ 3B722-A(6)	C7AZ 3E576-D (2), 87944-S8 (2)
C0SS 3A714-B	C7AZ 3B722-A(6)	C7AZ 3E576-D (2), 87944-S8 (2)
C1AA 3A714-A	C7AZ 3B722-A(6)	C7AZ 3E576-D (2), 87944-S8 (2)

@ Cut to appropriate length from C7AZ 3A005-A (3/8" I. D. -5/8" O. D.) bulk hose and use (2) B5A 2344-A clamps

3A719 POWER STEERING HOSE - continued

HOSE ASSEMBLY	REPLACED BY	
	BULK HOSE or TUBING LENGTH IN INCHES	FITTINGS, ETC. (USE QUANTITY SHOWN)
C2OZ 3A714-A	C7TZ 3B722-A(6)	C7AZ 3E576-D (2), 87944-S8 (2)
C3AZ 3A714-A	C7TZ 3B722-A(6)	C7AZ 3E576-D (2), 87944-S8 (2)
C3DZ 3A714-A	C7AZ 3B722-A(6)	C7AZ 3E576-D (2), 87944-S8 (2)
C3DZ 3A714-B	C7AZ 3B722-A(6)	C7AZ 3E576-D (2), 87944-S8 (2)
C3OZ 3A714-A	C7AZ 3B722-A(6)	C7AZ 3E576-D (2)
C0AA 3A717-A	C7AZ 3B722-A(6)	C7AZ 3E576-D (2), 87944-S8 (2)
C0SS 3A717-B	C7AZ 3B722-A(6)	C7AZ 3E576-D (2), 87944-S8 (2)
C2OZ 3A717-A	C7AZ 3B722-A(6)	C7AZ 3E576-D (2), 87944-S8 (2)
C3AZ 3A717-A	C7AZ 3B722-A(6)	C7AZ 3E576-D (2), 87944-S8 (2)
C3DZ 3A717-A	C7AZ 3B722-A(6)	C7AZ 3E576-D (2), 87944-S8 (2)
C3DZ 3A717-B	C7AZ 3B722-A(6)	C7AZ 3E576-D (2), 87944-S8 (2)
C3OZ 3A717-A	C7AZ 3B722-A(6)	C7AZ 3E576-D (2), 87944-S8 (2)
B9SZ 3A719-A	C7SZ 3A609-A(7 1/4), C7AZ 3A719-C (A-8 & B-12)	C7AZ 3E576-C (1), C7AZ 3B762-A (1), 87943-S8 (1)
C0AZ 3A719-A	C7AZ 3A719-C (A-8 & B-11)	C7AZ 3E576-C (1), C7AZ 3E576-J (1), C7AZ 3B762-B (1), 87943-S8 (1), 357939-S (1), 357941-S (1)
C0AZ 3A719-B	C7AZ 3B712-B(12), C7AZ 3A719-C (A-8 & B-11 1/4)	C7AZ 3E576-C (1), C7AZ 3B762-A (1), 87943-S8 (1), 87945-S8 (2)
C1AA 3A719-C	C7AZ 3B712-B(12), C7AZ 3A719-C (A-7 15/16 & B-11 7/16)	C7AZ 3E576-F (1), C7AZ 3B762-A (1), 87945-S8 (2)
C1AA 3A719-D	C7AZ 3A719-C (A-7 15/16 & B-11 7/16)	C7AZ 3E576-F (1), C7AZ 3E576-J (1), 357939-S (1), 357941-S (1), C7AZ 3B762-B (1)
C2OZ 3A719-C	C7AZ 3A719-C (A-16 11/16 & B-12 5/16)	C7AZ 3E576-B (1), C7OZ 3E576-D (1), 87945-S8 (1)
C2OZ 3A719-D	C7AZ 3B712-B(12), C7AZ 3A719-C (A-21 & B-12)	C7OZ 3E576-D (1), C7AZ 3B762-A (1), 87945-S8 (1)
C3AZ 3A719-A	C7AZ 3A719-C (A-11 1/2 & B-11 1/2)	C7AZ 3E576-E (1), C7AZ 3E576-J (1), C7AZ 3B762-B (1), 357939-S (1), 357941-S (1)
C3AZ 3A719-C	C7AZ 3A719-C (A-7 15/16 & B-11 7/16)	C7AZ 3E576-H (1), C7AZ 3E576-J (1), C7AZ 3B762-B (1), 357939-S (1), 357941-S (1)
C3AZ 3A719-D	C7AZ 3B712-B(12), C7AZ 3A719-C (A-7 15/16 & B-11 7/16)	C7AZ 3E576-H (1), C7AZ 3B762-A (1), 87945-S8 (2)
C3DZ 3A719-A	C7AZ 3B712-B(12), C7AZ 3A719-C (A-13 5/16 & B-11 1/2)	C7DZ 3E576-B (1), C7AZ 3B762-A (1), 87945-S8 (2)
C3OZ 3A719-A	C7AZ 3B712-B(12), C7AZ 3A719-C (A-14 11/16 & B-11 11/16)	C7OZ 3E576-A (1), C7AZ 3B762-A (1), 87945-S8 (2)
C3OZ 3A719-B	C7AZ 3B712-B(12), C7AZ 3A719-C (A-20 11/16 & B-11 11/16)	C7OZ 3E576-A (1), C7AZ 3B762-A (1), 87945-S8 (2)
C3OZ 3A719-C	C7AZ 3A719-C (A-16 11/16 & B-11 11/16)	C7AZ 3E576-B (1), C7OZ 3E576-A (1), 87945-S8 (1)
C3SZ 3A719-A	C7SZ 3B712-A(12), C7AZ 3A719-C (A-8 & B-4 5/8)	C7AZ 3E576-B (1), C7SZ 3B762-A (1), 87944-S8 (2), 87945-S8 (1)
C4AZ 3A719-A	C7AZ 3B712-B(12), C7AZ 3A719-C (A-10 & B-12)	C7AZ 3E576-G (1), C7AZ 3B762-A (1), 87945-S8 (2)
C4AZ 3A719-B	C7AZ 3B712-B(12), C7AZ 3A719-C (A-10 & B-11 1/2)	C7AZ 3E576-H (1), C7AZ 3B762-A (1), 87945-S8 (2)
C4DZ 3A719-A	C7AZ 3A719-C (A-16 & B-11)	C7AZ 3E576-J (1), C7DZ 3E576-A (1), C7AZ 3B762-B (1), 357939-S (1), 357941-S (1)
C4SZ 3A719-A	C7SZ 3B712-A(cut to fit) C7AZ 3A719-C (A-14 11/16 & B-7 5/8)	C7AZ 3E576-D (1), C7AZ 3E576-J (1), C7AZ 3B762-B (1), C7SZ 3B762-A (2) 87944-S8 (3) 357939-S (1), 357941-S (1)

3A719 POWER STEERING HOSE - continued

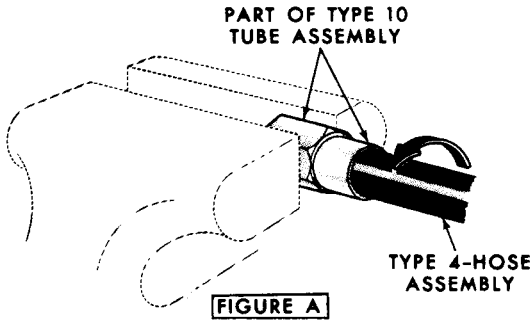

FIGURE A

WET A SHARP KNIFE BLADE AND CUT HOSE ENDS TO LENGTH. PLACE SHELL IN VISE. SCREW HOSE COUNTER-CLOCKWISE IN SHELL UNTIL HOSE BOTTOMS. BACK OFF APPROXIMATELY 1/4 TURN.

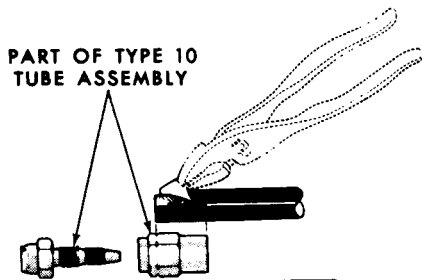

FIGURE B

TO ASSEMBLE REUSABLE COUPLINGS TO WIRE BRAID HOSE—PLACE HOSE IN VISE AND CUT END SQUARE TO LENGTH. USE FINE TOOTH HACKSAW (18 TEETH PER INCH PREFERRED). CUT WITH KNIFE THRU COVER AROUND HOSE USING NOTCHES ON SHELL FOR LENGTH GUIDE. SLIT COVER FROM CUT TO END. REMOVE OUTER COVER USING SCREW DRIVER AND PLIERS. ASSEMBLE AS SHOWN IN FIGURE A.

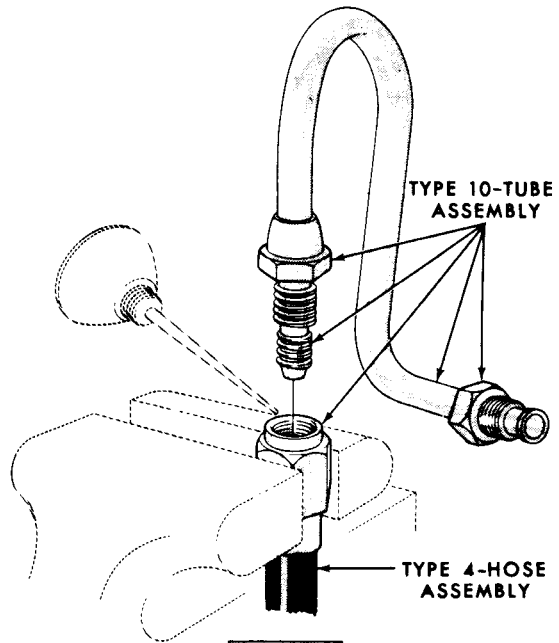

FIGURE C

LUBRICATE MALE AND FEMALE THREADS OF COUPLING BODY

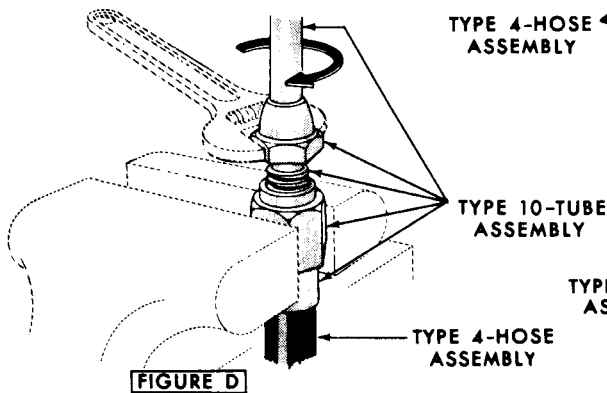

FIGURE D

INSERT LUBRICATED MALE BODY INTO COUPLING SHELL AND TURN CLOCKWISE UNTIL HAND TIGHT. APPLY WRENCH AND SCREW MALE BODY FULL LENGTH INTO SHELL.

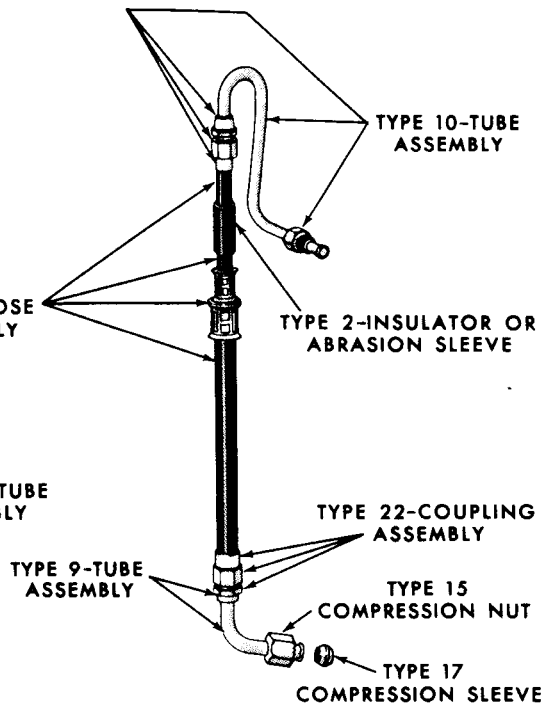

FIGURE E

TYPICAL APPEARANCE OF COMPLETED ASSEMBLY

P-6824

TYPICAL ASSEMBLY of P/S HOSE FROM FITTINGS & BULK HOSE

3A719 POWER STEERING HOSE - continued



TYPE 1
HOSE



TYPE 2
INSULATOR



TYPE 3
TUBING

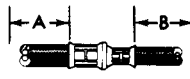

TYPE 4



TYPE 5

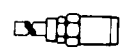

TYPE 6

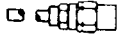

TYPE 7



TYPE 8



TYPE 9

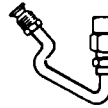

TYPE 10

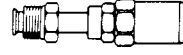

TYPE 11

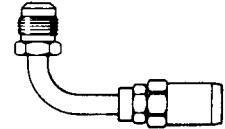

TYPE 12



TYPE 13



TYPE 14



TYPE 15



TYPE 16



TYPE 17



TYPE 18



TYPE 19



TYPE 20



TYPE 21

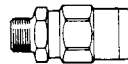

TYPE 22

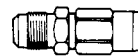

TYPE 23



TYPE 24

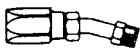

TYPE 25



TYPE 26

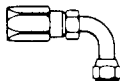

TYPE 27



TYPE 28

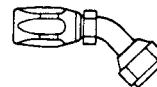

TYPE 29

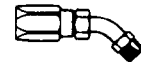

TYPE 30

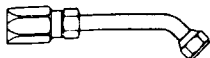

TYPE 31

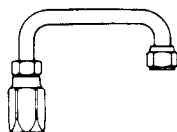

TYPE 32



TYPE 33

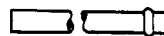

TYPE 34

P-6822

POWER STEERING HOSE REPLACEMENT FITTINGS
FOR PART NUMBERS SEE NEXT PAGE

3A719 POWER STEERING HOSE - continued

P/S HOSE FITTING INDEX - PART NUMBER TO TYPE

SEE ILLUSTRATION ON PREVIOUS PAGE

PART NUMBER	TYPE	DESCRIPTION	PART NUMBER	TYPE	DESCRIPTION
B7Q 2269-A	3	Tubing-steel-3/8" O.D.-25 ft. roll	C7AZ 3A713-H	13	Tube assy.-3/8" O.D. tube (bent)
B5A 2344-A	18	Clamp-5/8" dia.-with bolt and nut	C7DZ 3A713-B	13	Tube assy.-3/8" O.D. tube (bent)
C7AZ 3A005-A	1	Hose-3/8" I.D. x 5/8" O.D. x 25 ft.	C7OZ 3A713-D	13	Tube assy.-3/8" O.D. tube (bent)
C7TZ 3A005-A	1	Hose-1/2" I.D. x 15/16" O.D. x 5 ft.	C7CZ 3A713-E	13	Tube assy.-3/8" O.D. tube (bent)
C7AZ 3E576-C	7	Tube assy.-1/4" O.D. tube (straight)	C7SZ 3A713-B	13	Tube assy.-3/8" O.D. tube (bent)
C7AZ 3E576-D	7	Tube assy.-5/16" O.D. tube (straight)	C7AZ 3A719-C	4	Hose assy.-reduction (w/ctr. coupling)- "A" dimension is 3/8" I.D. -23" long- "B" dimesion is 1/4" I.D. -20" long
C7AZ 3E576-E	10	Tube assy.-1/4" O.D. tube (bent)	C7AZ 3B722-A	1	Hose-1/4" I.D. x 10 ft.
C7AZ 3E576-F	10	Tube assy.-1/4" O.D. tube (bent)	C7TZ 3B722-A	1	Hose-3/8" I.D. x 3/4" O.D. x 25 ft.
C7AZ 3E576-G	10	Tube assy.-1/4" O.D. tube (bent)	C7OZ 3B762-A	20	Coupling-hose-2" long
C7AZ 3E576-H	10	Tube assy.-1/4" O.D. tube (bent)	C7AZ 3B762-B	22	Coupling-hose-2" long
C7AZ 3E576-J	8	Tube assy.-3/8" C.D. tube	C7SZ 3B762-A	21	Coupling-hose-13/16" long
C7DZ 3E576-A	10	Tube assy.-1/4" O.D. tube (bent)	87943-S8(I-21)	14	Fitting-1/4" tube (7/16"-24 thread)
C7OZ 3E576-A	10	Tube assy.-1/4" C.D. tube (bent)	87944-S8(I-22)	14	Fitting-5/16" tube (1/2"-20 thread)
C7CZ 3E576-D	10	Tube assy.-1/4" O.D. tube (bent)	87945-S8(I-23)	14	Fitting-3/8" tube (5/8"-18 thread)
C7AZ 3A609-A	2	Insulator-45/64" I.D. x 53/64" O.D.	357939-S(MM112A)	15	Nut-3/8" tube (9/16"-24 thread)
C7SZ 3A609-A	2	Insulator-9/16" I.D. x 11/16" O.D.	357941-S(II-55A)	17	Fitting-compression-3/8" dia.
C7AZ 3B712-B	3	Tubing-steel-3/8" O.D.-24" long			
C7SZ 3B712-A	3	Tubing-steel-5/16" O.D.-24" long			
C7AZ 3A713-G	13	Tube assy.-3/8" O.D. tube (bent)			

YEAR	MODEL	DESCRIPTION	QTY.	PART NUMBER
3C719 GASKET - POWER STEERING OIL RESERVOIR FILTER				
60/	A, B, S	"From 7/1/60"	17/64" I.D. -13/16" O.D. -1/16" thick	1 C2SZ 3C719-A
63/	X			1
3B721 TUBE ASSY. - POWER STEERING RETURN LINE HOSE TO STEERING GEAR				
61/64	S		23 1/4" long-make from B7Q 2269-A tubing and 1-87945-S8 nut	1 *C1SS 3B721-B
3B726 ADAPTOR ASSY. - POWER STEERING OIL RESERVOIR INLET TUBE - Also refer to Group 3670				
62/63	S (with A/C)	"From 6/1/62"	For 3/4" tube	1 C2SZ 3B726-A
61/62	S (with A/C)		Bolt (adaptor to pump)-3/8"-16 x 2 3/8"	AR 350388-S (BB159)
3C726 BUMPER - MOVABLE STEERING COLUMN TRACK STOP BRACKET				
63/64	A(Automatic transmission)		13/16" O.D. -1/4" thick	2 C3AZ 3C726-A
64	S		L. H.	1
64/	S		R. H. -13/16" O.D. -27/64" thick	1 C4SZ 3C726-A
63	A		Screw (retaining)-5/16"-18 x 1 13/32"	1 377942-S2 (BB817V)
			Nut-5/16"-18	1 34056-S8(M160)
			Screw (retaining)-5/16"-18 x 1 21/32"	1 or 2 377978-S2 (BB817W)
64/	S		Nut-5/16"-18	2 33797-S7(M50)
3C727 PIN - MOVABLE STEERING COLUMN TO TRACK LOWER BRACKET				
63	A(with F/M/2 & C/M)		1/2" long	2 C3AZ 3C727-A
3A728 CLAMP - POWER STEERING HYDRAULIC CONTROL				
62/	A			1 C2AZ 3A728-A
62/	B			1
62/	X			1
3C728 BEARING - MOVABLE STEERING COLUMN TO TRACK LOWER BRACKET				
63	A(with F/M/2 & C/M)			2 C3AZ 3C728-A
64/	A, S			2 C5AZ 3C728-A
64/	A, S		Set screw (bearing to upper track bracket)- 5/16"-32 x 11/16"	2 378562-S2 (UU38)
			Nut-5/16"-32	378563-S2(MM54D)
3A729 COVER - POWER STEERING LINKAGE DUST				
62/	A, B, X			1 C7OZ 3A729-A

YEAR	MODEL	DESCRIPTION	QTY.	PART NUMBER
3A730 VALVE ASSY. - POWER STEERING HYDRAULIC CONTROL				
60	A, S		1	C0AA 3A730-D
61/62	A		1	C2AZ 3A730-A
63/64	A		1	C3AZ 3A730-A
62/64	B		1	C3OZ 3A730-B
63/64	X		1	C3DZ 3A730-B
60/	A, S, X	Bolt (clamp)-3/8"24 x 1 1/2"	1	20469-S8(B174)
		Nut 3/8"-24		33800-S8(M63)
		Lockwasher-3/8"		357629-S7(XX303)
60/	A, B, S, X	Seat-3/8" tube-aluminum	1	372896-S(TT6)
60/	A, B, S, X	Seat-5/16" tube-aluminum	2	373430-S(TT5)
60/	A, B, X	Screw & washer assy. (valve housing to ball	2	373406-S
60	S	stud)-5/16"-18 x 7/8"	2	
		Lockwasher-5/16"		34806-S7(X64)
60/	A, S, X	Fitting (lubricator)-1/4"-28	1	87907-S(I-3)
63/	A, X	Plug (valve)-1/4"-28	1	374714-S7-8 (PP35A)
60/	A, B, S, X	Seat-1/4" tube-aluminum	1	372895-S(TT3)
		Nut(clamp)-5/16"-24	1	34443-S(M79)
3B730 PLUG - POWER STEERING GEAR				
61/63	S		1	C1VR 3B730-A
64	S		1	C4SZ 3B730-A
61/64	S	Snap ring (plug)	1	353650-S100(QQ II)
64	S	"O" ring (plug)	1	87025-S94(T2C)
3C730 SPRING - MOVABLE STEERING COLUMN TO TRACK LOWER BRACKET				
63	A	13/16" long-25 1/2 coils	2	C3AZ 3C730-A
3A732 BRACKET - POWER STEERING PUMP ADJUSTING - Also refer to Group 3C511				
60/62	A (8 cyl. 292)		1	B8AZ 3A732-B
60/63	A(8 cyl. 352, 390)		1	B8AZ 3A732-A
60	S(8 cyl. 352)		1	
64	A(8 cyl. 352, 390)	With H/D alt. or dealer installed economy A/C	1	
60/	A(6 cyl.)		1	B7AZ 3A732-B
64	A(8 cyl. 352, 390) -without A/C		1	C4AZ 3A732-A
64	A(8 cyl. 352, 390)-with A/C		1	C4AZ 3A732-B
64	S (with A/C)		1	
63/64	A (8 cyl. 260, 289)-without A/C "From 2/1/63"	Rear	1	C3AZ 3A732-A
64	B(without A/C)		1	
62/64	B(8 cyl.)-with A/C	Rear	1	C2OZ 3A732-C
62/64	B (6 cyl.)-with Automatic Trans.		1	C2OZ 3A732-A
64	X(6 cyl.)-with or without A/C		1	
63/64	B(8 cyl.)	Front	1	C3OZ 3A732-A
63/64	A(8 cyl. 260, 289)		1	
63/64	X (8 cyl.)		1	
63	B(8 cyl.) "From 3/18/63"	Rear	1	C3OZ 3A732-C
63	A (8 cyl. 260, 289) "Before 2/1/63"		1	
63/64	A(8 cyl. 260, 289)-with A/C		1	
63/64	X(8 cyl.)		1	
64	B(8 cyl.)-with A/C		1	
61/63	S (with A/C)		1	C1SE 3A732-A
61/64	S (without A/C)		1	C1SE 3A732-B
60/62	A-8 cyl. 292 (except 59A)	Bolt (brkt. to gen. mounting brkt.)-3/8"-16 x 1 1/4"	1	20428-S7-8(B82)
62/	B (6 cyl.) -with F/M/2		1	
60/62	A-8 cyl. 292	Bolt (bracket to manifold bracket)	1	
60/	A-8 cyl. , S	Bolt (bracket to water pump)	2	
60/	A (8 cyl.)-with A/C		1	
62/	B-8 cyl.	Bolt (bracket to compressor mounting bracket)-	2	20349-S7-8(B170)
63	A-8 cyl. 260	3/8"-24 x 3/4"	2	
		Washer-flat-3/8"		352981-S(XX143)
		Lockwasher-3/8"		34807-S8(X66)
64	A(8 cyl. 352, 390)-without A/C	Bolt (to pump)-3/8"-16 x 3 1/16"-self-locking	3	359099-S(BB417)
		Nut-3/8"-16	1	33799-S7(M52)
		Lockwasher-3/8"		34807-S8(X66)
60/62	A-8 cyl. 292	Bolt (bracket to exhaust manifold bracket)-	1	20448-S8(B83)
		3/8"-16 x 1 3/8"		

YEAR	MODEL	DESCRIPTION	QTY.	PART NUMBER
3A732 BRACKET - POWER STEERING PUMP ADJUSTING - continued				
60/	A-6 cyl.	Bolt (bracket to generator mounting bracket)- 3/8"-16 x 1 1/8"	1	20408-S7(B81)
60	S (8 cyl. 352)	Washer-flat (bracket to windshield washer)- 29/64"	2	356214-S8(XX162)
60/	A-6 cyl.	Bolt (brkt. to generator mounting brkt.)-3/8"-16 x 1" Bolt (bracket to support)	1	20388-S8(B80)
60/	A-8 cyl.		1	
62	B (6 cyl.)-with F/M/2		1	
63	B(8 cyl.)		1	
64	X(8 cyl.)		1	
60/	A-8 cyl., S	Washer-flat-3/8"		44727-S8(X24)
60	S (8 cyl. 352)-with A/C	Bolt (support bracket to adjusting bracket)- 3/8"-16 x 7/8"	1	356685-S8(BB153)
		Washer-flat-3/8"		44727-S8(X24)
60	S (8 cyl. 430)	Bolt (bracket to cylinder block)-7/16"-14 x 1"	2	20390-S8(B102)
60	S (8 cyl. 430)	Lockwasher-7/16"		34808-S8(X67)
60/	A	Bolt (bracket to pump)-3/8"-16 x 2"	3	20522-S8(B89)
62/	B (8 cyl.)-without A/C	Screw (bracket to support)-upper hole- 3/8"-16 x 1 9/16"	1	376532-S8(WW118)
63	A(8 cyl. 260)		1	
61/63	A (8 cyl. 352, 390)-without A/C	Bolt (bracket to pump)-3/8"-16 x 2 3/8"	2	350388-S(BB159)
61/	A-8 cyl. 352, 390(with A/C)		1	
61/	S		3	
60/	A (6 cyl. & 8 cyl.)	Bolt (bracket to pump)-3/8"-16 x 2 1/8"	1 or 3	370967-S(BB158)
62/	B (6 cyl.)-with Automatic Trans.		5	
63/	B(8 cyl.)		3	
64	X(6 cyl.)		5	
64	X(8 cyl.)		1	
64	S	Bolt (to water pump)	1	
60	A	Bolt (bracket to pump)-3/8"-16 x 2 1/2"	1	371741-S(BB160)
61/	A-8 cyl. 352, 390		1	
60/62	A (8 cyl. 292)	Bolt (bracket to pump)-3/8"-16 x 3"	3	45534-S8(B95)
62	B (8 cyl.)-with A/C	Bolt (bracket to pump)-3/8"-16 x 3 3/4"	2	356684-S8(BB169)
63	B(6 cyl.)-with F/M/2	Bolt (bracket to pump)-3/8"-16 x 1 1/8"	1	354135-S7-8 (BB155A)
64	S		1	
64	A(8 cyl. 352, 390)-with A/C	Bolt (to cylinder head)	1	
64	X(6 cyl.)	Bolt (to pump support)	1	
63/	A (8 cyl. 260, 289)	Screw & washer (bracket to cyl. head)-3/8"-16 x 1"	2	373293-S8(BB563)
63	B(8 cyl.)		2	
63/	X(8 cyl.)		3	
63/	A(8 cyl. 260, 289), B, X(8 cyl.)	Bolt (bracket to pump)-3/8"-16 x 3 3/4"	1 or 2	377957-S7-8 (BB169A)
63/	A (8 cyl. 260, 289), B, X(8 cyl.)	Stud (bracket to cylinder block)- 5/16"-18 & 5/16"-18 x 4 9/16" hex. shoulder	1	377958-S7-8 (WW104)
3A733 PULLEY - POWER STEERING PUMP - Also refer to Group 6A312				
60	A, S (all except 8 cyl. 430)	Flat hub type-4 1/16" O. D. -3/8" single sheave	1	B8AZ 3A733-A
60/63	A, S (8 cyl. 292, 352, 390)	4" O. D. -1/2" single sheave-deep dish type	1	C0AE 3A733-A
64	A(8 cyl. 352, 390)-with H/D alternator w/o A/C		1	
64	A(8 cyl. 352, 390)-without A/C	4 7/16" O. D. -1/2" single sheave	1	C4AZ 3A733-A
64	A (8 cyl. 352, 390)-with A/C	5 1/4" O. D. -3/8" single sheave	1	C4AZ 3A733-B
64	S (with A/C)		1	
62/64	B (6 cyl.)-with Automatic Trans.	4 7/16" O. D. -27/64" single sheave	1	C2OZ 3A733-A
64	X(6 cyl.)-without A/C "Before 3/2/64"		1	
64/	X(6 cyl.)-with A/C & Eaton Pump- "From 3/2/64"		1	
62	B (8 cyl.)	4 7/16" O. D. -1/2" single sheave	1	C2OZ 3A733-B
61/63	S (with A/C)	4" O. D. -1/2" single sheave	1	C1SE 3A733-A
61/64	S (without A/C)	4 7/16" O. D. -1/2" single sheave	1	C1SE 3A733-B
61/64	A (6 cyl. & 8 cyl. 289, 292)		1	
63	A(8 cyl.)		1	
63	A(8 cyl. 260), B(8 cyl.)-with A/C		1	
63/64	B(8 cyl.)		1	
64	X(8 cyl.)		1	

YEAR	MODEL	DESCRIPTION	QTY.	PART NUMBER
3A733 PULLEY - POWER STEERING PUMP - continued - Also refer to Group 6A312				
63/64	X(6 cyl.)-with A/C	"Before 3/2/64"	4 7/16" O.D. -27/64" single sheave-deep dish type	1 C3DZ 3A733-A
64/	X(6 cyl.)-without A/C	"From 3/2/64"		1
60/	A, B, S, X		Bolt (pulley to pump)-5/16"-18 x 7/8"	1 20366-S8(B52)
			Lockwasher -5/16"	34806-S7(X64)
			Washer-flat-5/16"	353846-S8(XX120)
			Washer-flat-5/16"	44725-S8(X22)
			Key-woodruff (pulley to pump)-1/8" x 1/2"	1 74172-S(L3)
3C733 RETAINER - MOVABLE STEERING COLUMN LOCKING LEVER SPRING				
63/	A(with Automatic Trans.)			1 C3AZ 3C733-A
64/	S			1
3A734 ARM & BUSHING ASSY. - STEERING IDLER - Refer to Group 3355				
3C734 LOCATOR - MOVABLE STEERING COLUMN TRACK				
64/	A			1 C4AZ 3C734-A
64/	S			1
3738 SEAL - STEERING SHAFT				
61	A	"Before 9/16/60"	Saginaw steering gear-Rubber & Steel 1 1/16" I.D. -1 5/16" O.D.	1 C1AR 3738-B
61	A	"From 9/16/60"	Rubber-23/32" I.D. -1" O.D. -use with C1MR 3504-C, D, F & G	1 B5S 3738-A
62/	A, B			1
3-3739 CLAMP - POWER STEERING VALVE BALL STUD SLEEVE				
61/	A, B, X			1 B7A 33739-A
3A740 GASKET - POWER STEERING CONTROL VALVE BODY				
60/	A, B, X			1 C1AA 3A740-B
60	S			1
3B740 PLUG - POWER STEERING CONNECTING LINK BALL STUD SEAT				
61/	A, B, X			1 C1AA 3B740-B
3C742 RETAINER - POWER STEERING PUMP RELIEF VALVE - Also refer to Group 3-3627				
63/	B, X			1 C3OZ 3C742-A
3B743 REINFORCEMENT - STEERING COLUMN SUPPORT BRACKET				
64	A(fixed column)			1 C4AZ 3B743-A
3A745 CAP - POWER STEERING CYLINDER				
61/64	S			1 C3SZ 3A745-A
3A746 RING - POWER STEERING CYLINDER CAP RETAINING				
61/64	S			1 C2VZ 3A746-A
3C750 CLAMP - POWER STEERING HOSE - Also refer to Group 3A762				
63/	B, X			1 C3DZ 3C750-B
63/64	A		Pressure hose to valve	1
3A754 SOCKET - POWER STEERING CONTROL VALVE BALL STUD				
60	A, S			1 C0AA 3A754-A
61/	A, B, X			1 C1AA 3A754-C
3B754 SEAT - POWER STEERING OIL RESERVOIR FILTER ELEMENT RETAINING SPRING				
62/	A, B, S	"From 5/1/62"	Depth 1/8"	1 B4AZ 3B754-A
63/	X			1
3C755 CLAMP - POWER STEERING CYLINDER PISTON ROD BOOT				
63/64	A			1 C3AZ 3C755-A
63/	B, X			1

FORD CAR PARTS

SECTION 37

YEAR	MODEL	DESCRIPTION	QTY.	PART NUMBER
3757 KIT - POWER STEERING VALVE SPOOL RETAINING RING				
61/	S	Consists of (1 ea.) WAN 3757-A, B, C, D, E Ring	1	C1SZ 3757-A
3B760 TRIM - STEERING COLUMN OPENING COVER				
62	A(65B, 76B)		1	C2AZ 3B760-A
3C760 SPACER - STEERING SHAFT COUPLING				
63/64	A		2	C3AZ 3C760-A
3A762 CLAMP ASSY. - POWER STEERING HOSE - Also refer to Group 3C750				
63/	A	Return line to pressure line at coupling	AR	C3AZ 3A762-A
64/	S		2	
3C762 BRACE - MOVABLE STEERING COLUMN TRACK INNER - Also refer to Group 3C557				
63	A		1	C3AZ 3C762-A
64	A		1	C4AZ 3C762-A
64	S		1	C4SZ 3C762-A
3A764 KIT - POWER STEERING CYLINDER SEAL				
60/64	A	Consists of 1-C1AA 3C561-A Spacer 1-C0AA 3A753-A Scraper 1-C1AA 3A751-A Bushing 2-AJ 33656-A Seal 1-C1AA 3A752-A Seal 1-371033-S Ring	1	C1AZ 3A764-A
62/	B		1	
60	S		1	
63/	X		1	
60/61	S	Consists of 1-C1AZ 7A294-A Seal 1-C1VR 3805-A Seal 1-87079-S94 Seal 1-87078-S94 Ring	1	C0SZ 3A764-A
3C773 BUSHING - STEERING SHAFT				
63/	S		1	C3SZ 3C773-B
3790 EXTENSION - STEERING COLUMN TUBE FLANGE				
62/	X(with 4 speed trans.)	2 53/64" long	1	C3DZ 3790-A
63/	B (8 cyl.)-with 4 speed trans.		1	
63/	A(57C, 63C, 65B, 76B)-with 4 speed S/T	With fixed steering column	1	
63/	A(71G, H, 75C)-F/M/2 & C/M-console mounted	With moveable steering column	1	
3812 ACTUATOR - POWER STEERING VALVE				
61/64	S		1	B8LY 3812-A
3821 ADJUSTER - POWER STEERING CONTROL VALVE SLEEVE LOCK NUT				
61/	S		1	C1SZ 3821-A
3836 TUBE ASSY. - POWER STEERING PRESSURE HOSE TO PUMP				
62	B (8 cyl.)		1	★C2OZ 3836-A
3839 RETAINER & BEARING ASSY. - STEERING COLUMN - UPPER - Also refer to Group 3B610				
61/62	A		1	C1AA 3839-C
64/	S	Retainer only	1	C6SZ 3839-A
62/	B	Steering shaft	1	
63/	A		1	
63/	X		1	
61/62	A	Ring (sleeve retaining)- 1 23/64"	1	374712-S(XX332)
61/62	A, S	Ring (bearing retaining)-upper-3/4"	1	372876-S(QQ38A)
61/62	A, S	Ring (bearing retaining)-lower-3/4"	1	372875-S(QQ88)
61/62	A	Screw (retainer to column)-No. 10-24 x 1/4"- oval head	3	374720-S13 (BB600)

FORD DESIGN REAR AXLE MODEL IDENTIFICATION TAG

Effective with the 1963 models, a service identification tag was attached to the Ford design rear axles as illustrated below. Inquiries pertaining to rear axles used on 1963 and subsequent models should include the axle model identification number.

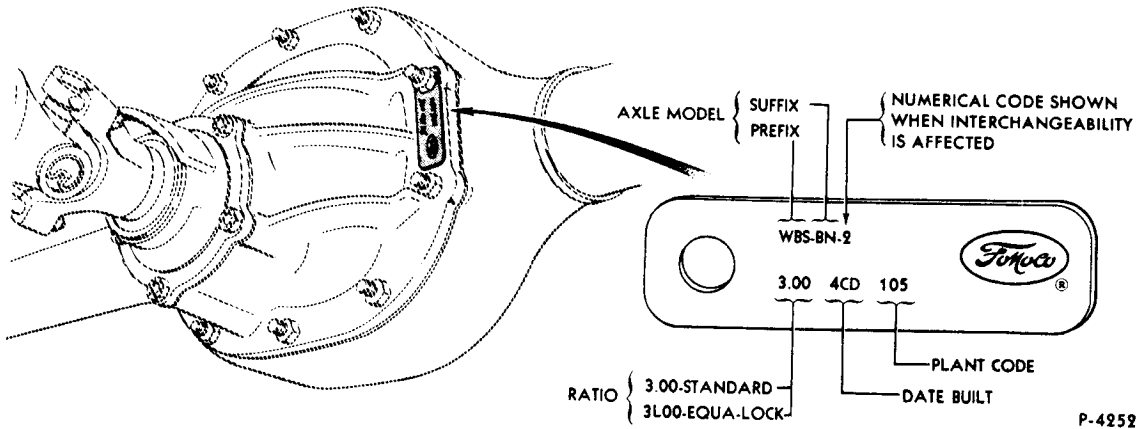

P-4252

REAR AXLE IDENTIFICATION CHART

The following chart lists models of Ford design rear axles built since 1963 in alphabetical order. Axle model suffixes with numerical codes are shown only where interchangeability is affected by type of differential or size of differential bearing. This chart will assist in determining the application for rear axle components which are cataloged throughout Sections 40 & 46 by size, description, ratio, type of differential or reference to size of ring gear, wheel bearings & differential bearings. Abbreviations used in the "type", "whl. brg." and "diff. brg. & cup" columns have the following meanings:

TYPE	
C.....Conventional	2 pinion - non-locking
C4.....Conventional	4 pinion - non-locking
E.....Equalock	2 pinion - limited slip
E4.....Equalock	4 pinion - limited slip

WHEEL BEARING				DIFFERENTIAL BEARING			
		I.D.	O.D.		I.D. &	CUP	O.D.
XS...Extra small	(CODZ 1225-A)	1 13/16"	2 7/16"	S...Small	(CIUW 4221-A 1 1/2")	(CIUW 4222-A 2 9/16")	
S...Small	(CODZ 1225-C)	1 21/64"	2 43/64"	M...Medium	(B7A 4221-A 1 5/8")	(B7A 4222-A 2 57/64")	
M...Medium	(B7AZ 1225-A)	1 3/8"	2 53/64"	L...Large	(B7A 4221-B 1 25/32")	(B7A 4222-B 3 1/16")	
L...Large	(C1SZ 1225-B)	1 17/32"	3 5/32"	XL...Extra large	(B7T 1201-A 1 51/64")	(C3TZ 1202-B 3 17/64")	

4A001 TUBE - REAR AXLE HOUSING - VENT - Cut from 17543 or C2AZ 9324-C hose					
YEAR	MODEL	AXLE IDENTIFICATION	PART NUMBER	QTY.	DESCRIPTION
62/	B		*353473-S8	1	Clip (rubber coated)
62/	B, F		355428-S(KK9)	1	Grommet-, 50" diam. hole
62/	A, B, S, X		375416-S35(EE4)	1	Clamp-9/16" hose
62/	B		40923-S8(U264)	1	Screw (tube to underbody)- 5/16"-18 x 1/2" washer head tapping
60	A		C0AZ 8287-A	1	Clamp-1/2" band type
4010 HOUSING ASSY. - REAR AXLE					
- A -					
60/62	A		C3AZ 4010-D	1	Used w/medium wheel brgs. -2.835" I. D.
63/64	A	WBS		1	
60/62	A (H/D)		C3AZ 4010-G	1	Used w/large wheel brgs. -3.150" I. D.
63/64	A	WBT, WBV, WCN		1	
- B -					
62	B		C2OZ 4010-D	1	Backing plate flange inside of hsg. tube- use C4OZ 1177-A seal
63	B	WCL	C3OZ 4010-D	1	
64/	B	WCL, WDK	C4OZ 4010-B	1	Regular & locking axle (includes C4OZ 4159-A lubricator
63/	B	WCU	C3OZ 4010-C	1	Backing plate flange inside of hsg. tube- use C4OZ 1177-A seal
- S -					
63	S	WDE	C3SZ 4010-A	1	Locking axle
63	S	WCD	C3SZ 4010-B	1	Large wheel bearings
64/	S	WCD, WDE	C6SZ 4010-B	1	Large wheel bearings
- X -					
60/62	X(6 cyl. 144)-6 3/4" ring gear		C3DZ 4010-J	1	3.10, 3.50 ratio-used with extra small wheel brgs. -2 7/16" O. D. -1 13/16" I. D.
60/63	X(71,76,86A)(6 cyl. 144)- 6 3/4" or 7" ring gear		C3DZ 4010-G	1	
64	X(6 cyl. 144)-6 3/4" or 7" ring gear	WCY	C4DZ 4010-C	1	3.50, 4.00 ratio-use with small wheel brgs. -2 43/64" O. D. -1 21/64" I. D. Small wheel brg. -carrier height 8 1/2"
61/63	X(exc. S/D, S/W, 86A)- 6 cyl. 170-7 1/4" ring gear	WBW	C3DZ 4010-F	1	3.20, 3.50 ratio-use with extra small wheel bearings
61/63	X(6 cyl.) 7 1/4" ring gear	WBY	C3DZ 4010-H	1	3.20, 3.50 ratio-use with small wheel bearings-2 43/64" O. D. -1 21/64" I. D.
64/	X(6 cyl.)-7 1/4" ring gear	WCY	C4DZ 4010-G	1	Small wheel brg. 2 43/64" O. D. - 1 21/64" I. D.
63	X	WCS	C3DZ 4010-A	1	Separate carrier
64/	X(8 cyl.)	WCZ, WDJ	C4DZ 4010-F	1	Includes (1) 378511-S clamp- medium wheel bearing
60/61	A, S		87710-S(P16)	1	Plug(drain)- 3/8"-18-hex. countersunk
60/	A		358048-S(PP43)	1	Plug(filler)- 3/4"-14 -sq. countersunk
62/	A, B, S, X			1	Plug (drain)
62/	A		87875-S(P17)	1	Plug(drain&fill)-1/2"-14-hex.countersunk
62/	A, B, S		379166-S(PP54N)	1	Plug (filler)-7/8"-18 hex. head
61/	A, B, S, X		373820-S(XX155A)	5	Washer-flat (housing to carrier)- lower bolts-3/8"
63	A, B, X		378511-S(EE9)	2	Clamp(brake line to axle housing)- 2 3/8" I. D. -1/2" thick
4020 RETAINER - REAR WHEEL BEARING - OUTER					
60/	A, B, X		C8UZ 4020-A	2	Used with medium wheel bearings
60/	A, S		C6AZ 4020-A	2	Used with large wheel bearings
63/	X(6 cyl.)		C3DZ 4020-A	2	Used with small wheel bearings
60/63	X		C0DW 4020-A	2	Used with extra small wheel bearings

FORD CAR PARTS

SECTION 40 101

YEAR	MODEL	AXLE IDENTIFICATION	PART NUMBER	QTY.	DESCRIPTION
4022 VENT ASSY. - REAR BRAKE LINE CONNECTION					
60/63	A		C2AZ 4022-A	1	
60/61	S			1	
64/	A		C2AZ 4022-C	1	Right angle outlet
62/	B		C2OZ 4022-A	1	2 1/8" long-7/16" -20 thread 3/4" long
63/	X			1	
62/	S		C2SZ 4022-A	1	
60/62	X		C0DD 4022-A	1	
62	A		*353473-S8	1	Clip (vent to frame side member)
63	A		375416-S35(EE4)	1	Clamp(vent hose to vent at axle)-7/16" hose
62	S		87942-S8(I-20)	1	Tube nut-3/8" -24 for 3/16" tubing
62	S		42143-S8(U255)	2	Screw (vent to body side member)- No. 14-10 x 3/4" hex. washer head tapping
63	S		87531-S(I-11)	1	Nut (for 3/16" tube)-3/8" -24
4033 COVER - REAR AXLE HOUSING					
60/	B, X (6 3/4", 7", 7 1/4" ring gear)		C1DW 4033-A	1	
60/	X		20348-S8(B77)	8	Bolt (cover to carrier)-3/8"-16 x 3/4"
60/	X		34807-S8(X66)	8	Lockwasher-3/8"
4035-6 GASKET - REAR AXLE CARRIER or COVER					
60/	A, B, S(8 3/4", 9" ring gear)		B7A 4035-A	1	Carrier to housing
60/	B, X(6 3/4", 7 1/4" ring gear)		C1DZ 4036-A	1	Cover to housing
62/	B, X(7 3/4", 8 ring gear)		C9OZ 4035-A	1	Carrier to housing
4A049 HOSE - REAR AXLE HOUSING VENT					
62/	A, B		*C2AA 4A049-B	1	19" long-cut from B4C 4090-A - use (1) 375416-S35 clamp
62/	A, B		375416-S35(EE4)	1	Clamp-9/16" hose
4A050 SCOOP - DIFFERENTIAL CASE OIL					
62/	A, B, S, X(7 3/4", 8", 8 3/4", 9" ring gear)		C2OZ 4A050-A	1	
64/	X (6 3/4", 7", 7 1/4" ring gear)		C4DZ 4A050-A	1	With integral carrier & locking axle
4A058 HOSE ASSY. - REAR AXLE VENT					
62/	S		C2SZ 4A058-A	1	20 3/4" long
4067 NUT or SHIM - DIFFERENTIAL BEARING ADJUSTING					
60/	A, B, X		B7AZ 4067-A	2	Nut-2 31/32"-16-for medium bearing carriers-includes 1-C6AZ 4143-B lock
60/	A, B, X		B9AZ 4067-A	2	Nut-3 5/32"-16 stamped "L" for large bearing carriers
60/	B, X (6 3/4", 7", 7 1/4" ring gear)		C0DW 4067-B	2	Nut-2.6324"-16 for integral carrier
4090 HOSE - POWER BRAKE BOOSTER and AIR COMPRESSOR					
60/	A, S		B4C 4090-A	AR	3/8" I. D. -supplied in 25 ft. rolls
60/	A		B3T 4090-B	AR	1/2" I. D. -supplied in 25 ft. rolls
4141 CARRIER ASSY. - DIFFERENTIAL					
60/	A, B, X(8 3/4", 9" ring gear)		C0AZ 4141-C	1	With 2 57/64" O. D. -medium brg. cups- 5" dia. pinion mounting hole-8 3/4" R/G
60/	A, B, S(8 3/4", 9" ring gear)		C2AZ 4141-B	1	With 3 1/16" O. D. -large bearing cups
62/	B, X (7 3/4", 8" ring gear)		C2OZ 4141-C	1	With 2 57/64" O. D. -medium brg. cups- 4 1/4" dia. pinion mounting hole-8" R/G
62/	A (8 cyl. 406, 427)		372116-S(MM140E)	10	Nut (carrier to hsg.)-3/8"-24 thickload
60/	A, S, X		20538-S8(B125)	4	Bolt(cap to carrier)-1/2"-13 x 2 1/4"
			34809-S8(X-68)		Washer-1/2" Lock
62/	A, B, S, X		373820-S(XX155A)	10	Washer (5 bottom carrier to housing bolts)-3/8" flat
			34445-S7(M80)		Nut-carrier to hsg. 3/8"-24 (hex. lock)

YEAR	MODEL	AXLE IDENTIFICATION	PART NUMBER	QTY.	DESCRIPTION
4143 LOCK - DIFFERENTIAL BEARING ADJUSTING NUT					
60/	A, B, S, X (7 3/4", 8", 8 1/2", 8 3/4", 9" ring gear)		C6AZ 4143-A	2	
60/	B, X (6 3/4", 7", 7 1/4" ring gear)		C0DW 4143-B	2	
60/	A, B, S, X		350211-S(BB413)	2	Bolt(lock to diff. brg. cap)-5/16"-18x7/16"
60/	B, X		34806-S7(X64)		Lockwasher-5/16"
4159 LUBRICATOR - DIFFERENTIAL					
60/	A, B, S (8 3/4", 9" ring gear)		B9A 4159-A	1	With locking axle
64/	B, X (7 3/4", 8" ring gear)		C4OZ 4159-A	1	With locking axle
4A182-3 REINFORCEMENT ASSY. - REAR AXLE BUMPER MOUNTING					
64/	S		C4SZ 4A182-A	1	Outer-R, H.
			C4SZ 4A183-A	1	Outer-L, H.
4204-5 CASE ASSY. - DIFFERENTIAL GEAR					
60/61	A		C2AZ 4204-E	1	1. 628" dia. brg. journals-2 pinion locker-includes 2-C2OW 4228-A washer-no oil scoop
60/62	A, S		C2AZ 4204-H	1	1. 628" dia. brg. journals-2 pinion std. - (10) 7/16" dia. bolt holes-includes 2-C9OZ4228-A washers-no oil scoop
63/	A, S	WBS, WBT, WCN			
60/	A		C3AZ 4204-B	1	1. 628" dia. brg. journals-4 pinion std. - (10) 7/16" dia. bolt holes-with 4A050 oil scoop - to convert from 2 pinion
62	A		C2AZ 4204-M	1	1. 628" dia. brg. journals 2 pinion locker-with 4A050 oil scoop
	Includes -	1-C4AZ 4214-A Spring Washers	3-B9AZ 4945-A Plates		4-B9AZ 4947-A Plates
		2-C2OW 4228-A	1-C4AZ 4946-A Hub		
63	A	WBV	C2AZ 4204-R	1	1. 628" dia. brg. journals-2 pinion locker
	Includes -	1-C4AZ 4214-A Spring Washers	3-B9AZ 4945-A Plates		4-B9AZ 4947-A Plates
		2-C9CZ 4228-A	1-C4AZ 4946-A Hub		
64/	A	WBV	C4AZ 4204-E	1	1. 628" dia. brg. journals-2 pinion locker
60/62	A, S		C2AZ 4204-K	1	1. 784" dia. brg. journals-2 or 4 pinion std. (10)7/16"dia. bolt holes-includes 2-C9OZ 4228-A washers-no oil scoop - w/28 spline shaft
63/	A, S	WBT, WCD		1	
61/62	A		C2AZ 4204-G	1	1. 784" dia. brg. journals-4 pinion std. - (10) 7/16" dia. bolt holes-includes 2-C9OZ 4228-A washers-with 4A050 oil scoop -w/31 spline shaft
63/	A, S	WBT, WCD, WCN			
62/64	A(8 cyl. 406, 427)	WCN	C2AZ 4204-F	1	1. 784" dia. brg. journals-4 pinion std. - (10) 1/2" dia. bolt holes-with 4A050 oil scoop
61	A(8 cyl. 390)		*C1SW 4204-B	1	1. 784" dia. brg. journals-2 pinion locker-includes 2 C2OW 4228-A washers-no oil scoop-N/R (1-69)
62	A		C2AZ 4204-L	1	1. 784" dia. brg. journals-2 or 4 pinion locker-with 4A050 oil scoop
	Includes -	1-C4AZ 4214-A Spring Plates	3-B9AZ 4945-A		1-C4AZ 4946-A Hub
					4-B9AZ 4947-A Plates
63	A		C2AZ 4204-N	1	1. 784" dia. brg. journals-2 or 4 pinion locker
	Includes -	1-C4AZ 4214-A Spring Plates	3-B9AZ 4945-A		1-C4AZ 4946-A Hub
					4-B9AZ 4947-A Plates
64/	A, S	WBV, WDE	C4AZ 4204-B	1	1. 784" dia. brg. journals-2 pinion locker-with 4A050 oil scoop
62	B		C2OW 4204-A	1	1. 628" dia. brg. journals-2 pinion std.-(8" R/G)
63/	B	WCL	C2OZ 4204-C	1	1. 628" dia. brg. journals-2 pinion std. - (8" R/G)
64/	B	WDR	C4OZ 4204-A	1	1. 628" dia. brg. journals-2 pinion locker-with 4A050 oil scoop-(8" R/G)
63/	B	WCU	C2AZ 4204-H	1	1. 628" dia. brg. journals 2 pinion std. - includes 2-C2OW 4228-A washers-no oil scoop-(9" R/G)

YEAR	MODEL	AXLE IDENTIFICATION	PART NUMBER	QTY.	DESCRIPTION
4204-5 CASE ASSY. - DIFFERENTIAL GEAR - continued					
60	X		C0DW 4205-J	1	Except 3.10 to 1 ratio
60	X		★C0DW 4205-G	1	3.10 to 1 ratio -Not replaced
61/62	X	WBW, WBY, WCY	C1DW 4204-A	1	1.503" dia. brg. journals-2 pinion std. -
63/	X			1	Replaces one-piece case
61/	X		C1DW 4204-B	1	1.503" dia. brg. journals-4 pinion std. - to convert from 2 pinion
64/	X	WCY	C4DZ 4204-A	1	1.503" dia. brg. journals-2 pinion locker
63/	X	WCS, WCZ	C2OZ 4204-C	1	1.628" dia. brg. journals-2 pinion std.
64/	X	WDJ	C4OZ 4204-A	1	1.628" dia. brg. journals-2 pinion locker

4209 KIT - DIFFERENTIAL GEAR and PINION

RING GEAR and PINION IDENTIFICATION CHART LISTED NUMERICALLY BY STAMPED NUMBER ON RING GEAR

IDENTIFICATION NUMBER		RING GEAR & PINION PART NUMBER	REPLACED BY	IDENTIFICATION NUMBER		RING GEAR & PINION PART NUMBER	REPLACED BY
RING GEAR	PINION			RING GEAR	PINION		
C0AW 4210-A	C0AW 4610-A	C0AZ 4209-A	C0AZ 4209-E	C2AW 4210-D	C2AW 4610-R	C0AZ 4209-E	
C0DW 4210-A	C0DW 4610-A		C0DZ 4209-A	C2AW 4210-D	C2AW 4610-R	C0AZ 4209-E	
C0DW 4210-B	C0DW 4610-B		C0DZ 4209-A	C2AW 4210-E	C2AW 4610-D	C2AZ 4209-E	C0AZ 4209-E
C0DW 4210-C	C0DW 4610-C		C1DZ 4209-N	C2AW 4210-E	C2AW 4610-N	C2AZ 4209-E	C0AZ 4209-E
C0DW 4210-D	C0DW 4610-D		C1DZ 4209-N	C2AW 4210-E	C2AW 4610-R		C0AZ 4209-E
C0DW 4210-G	C0DW 4610-G	C0DZ 4209-A		C2AW 4210-F	C2AW 4610-B	C2AZ 4209-F	B7AZ 4209-L
C0DW 4210-G	C0DW 4610-M	C0DZ 4209-AC		C2AW 4210-F	C2AW 4610-K	C2AZ 4209-F	B7AZ 4209-L
C0DW 4210-G	C0DW 4610-S		C0DZ 4209-A	C2AW 4210-F	C2AW 4610-L	C2AZ 4209-F	B7AZ 4209-L
C0DW 4210-G	C1DW 4610-J	C1DZ 4209-J		C2AW 4210-G	C2AW 4610-C	C2AZ 4209-G	B7AZ 4209-J
C0DW 4210-G	C1DW 4610-J	C1DZ 4209-AA		C2AW 4210-G	C2AW 4610-M	C2AZ 4209-G	B7AZ 4209-J
C0DW 4210-G	C1DW 4610-J	C1DZ 4209-AA		C2AW 4210-H	C2AW 4610-A	C2AZ 4209-H	B7AZ 4209-K
C0DW 4210-H	C0DW 4610-B		C0DZ 4209-A	C2AW 4210-H	C2AW 4610-H	C2AZ 4209-H	B7AZ 4209-K
C0DW 4210-J	C0DW 4610-C		C1DZ 4209-N	C2AW 4210-H	C2AW 4610-J	C3AZ 4209-D	B7AZ 4209-K
C0DW 4210-J	C0DW 4610-H		C1DZ 4209-N	C2AW 4210-J	C2AW 4610-E	C2AZ 4209-J	C0AZ 4209-E
C0DW 4210-M	C0DW 4610-G		C1DZ 4209-J	C2AW 4210-J	C2AW 4610-J		C0AZ 4209-E
C0DW 4210-N	C0DW 4610-H	C0DZ 4209-B	C1DZ 4209-N	C2AW 4210-J	C2AW 4610-R	C2AZ 4209-J	C0AZ 4209-E
C0DW 4210-N	C0DW 4610-N	C0DZ 4209-Y	C1DZ 4209-T	C2AW 4210-K	C2AW 4610-F	C2AZ 4209-K	B7AZ 4209-L
C0DW 4210-R	C0DW 4610-K	C0DZ 4209-Z	C1DZ 4209-U	C2AW 4210-K	C2AW 4610-L	C2AZ 4209-K	B7AZ 4209-L
C0DW 4210-S	C0DW 4610-G		C0DZ 4209-A	C2AW 4210-L	C2AW 4610-G	C2AZ 4209-L	B7AZ 4209-K
C0DW 4210-S	C0DW 4610-L	C0DZ 4209-V	C1UZ 4209-D	C2AW 4210-L	C2AW 4610-J	C2AZ 4209-L	B7AZ 4209-K
C0DW 4210-T	C0DW 4610-R	C0DZ 4209-AA	C1DZ 4209-U				
C0DW 4210-T	C1DW 4610-K	C1DZ 4209-U					
C1DW 4210-A	C1DW 4610-A		C1DZ 4209-Y				
C1DW 4210-B	C1DW 4610-B		C1DZ 4209-R				
C1DW 4210-B	C1DW 4610-G		C1DZ 4209-N				
C1DW 4210-C	C1DW 4610-C		C1DZ 4209-Z				
C1DW 4210-C	C1DW 4610-F	C1DZ 4209-Z					
C1DW 4210-C	C1DW 4610-F	C1DZ 4209-Z					
C1DW 4210-D	C1DW 4610-G	C1DZ 4209-N					
C1DW 4210-D	C1DW 4610-G	C1DZ 4209-V					
C1DW 4210-D	C1DW 4610-K	C1DZ 4209-L	C1DZ 4209-T				
C1DW 4210-D	C1DW 4610-R		C1DZ 4209-Z				
C1DW 4210-E	C1DW 4610-D	C1DZ 4209-Y					
C1DW 4210-G	C1DW 4610-J		C1DZ 4209-J				
C1DW 4210-T	C1DW 4610-K	C1DZ 4209-T					
C1UW 4210-A	C1UW 4610-B	C1UZ 4209-D					
C2AW 4210-A	C2AW 4610-A	C2AZ 4209-A	B7AZ 4209-K				
C2AW 4210-A	C2AW 4610-H	C2AZ 4209-A	B7AZ 4209-K				
C2AW 4210-A	C2AW 4610-J	B7AZ 4209-K					
C2AW 4210-A	C2AW 4610-J	B7AZ 4209-K					
C2AW 4210-B	C2AW 4610-B	C2AZ 4209-B	B7AZ 4209-L				
C2AW 4210-B	C2AW 4610-K	C2AZ 4209-B	B7AZ 4209-L				
C2AW 4210-B	C2AW 4610-L	B7AZ 4209-L					
C2AW 4210-B	C2AW 4610-L	B7AZ 4209-L					
C2AW 4210-B	C2AW 4610-R		C0AZ 4209-D				
C2AW 4210-C	C2AW 4610-C	C2AZ 4209-C	B7AZ 4209-J				
C2AW 4210-C	C2AW 4610-M	C2AZ 4209-C	B7AZ 4209-J				
C2AW 4210-D	C2AW 4610-D	C2AZ 4209-D	C0AZ 4209-E				
C2AW 4210-D	C2AW 4610-N	C2AZ 4209-D	C0AZ 4209-E				
C2OW 4210-A	C2OW 4610-A	C2OZ 4209-A	C4OZ 4209-H				
C2OW 4210-A	C2OW 4610-D	C2OZ 4209-A	C4OZ 4209-H				
C2OW 4210-A	C2OW 4610-G	C2OZ 4209-A	C4OZ 4209-H				
C2OW 4210-B	C2OW 4610-B	C2OZ 4209-B	C4OZ 4209-J				
C2OW 4210-B	C2OW 4610-E	C2OZ 4209-B	C4OZ 4209-J				
C2OW 4210-B	C2OW 4610-H	C2OZ 4209-B	C4OZ 4209-J				
C2OW 4210-C	C2OW 4610-C	C2OZ 4209-C	C4DZ 4209-D				
C2OW 4210-C	C2OW 4610-F	C2OZ 4209-C	C4DZ 4209-D				
C2OW 4210-C	C2OW 4610-J	C2OZ 4209-C	C4DZ 4209-D				
C3AW 4210-A	C3AW 4610-A	C3AZ 4209-A	B8AZ 4209-C				
C3AW 4210-B	C3AW 4610-A	B8AZ 4209-B	B8AZ 4209-C				
C3AW 4210-B	C3AW 4610-A	B8AZ 4209-C					
C3AW 4210-B	C3AW 4610-D	B7AZ 4209-E	B7AZ 4209-J				
C3AW 4210-C	C3AW 4610-B		B7AZ 4209-L				
C3AW 4210-D	C3AW 4610-B	B7AZ 4209-J					
C3AW 4210-D	C3AW 4610-B	B7AZ 4209-N					
C3AW 4210-D	C3AW 4610-D	C3AZ 4209-B	B7AZ 4209-L				
C3OW 4210-A	C3OW 4610-A	C3OZ 4209-A	C3OZ 4209-D				
C3UW 4210-A	C3UW 4610-A	C3UZ 4209-A	C3UZ 4209-C				
C3UW 4210-B	C3UW 4610-A	C3UZ 4209-B	C3UZ 4209-C				
C3UW 4210-B	C3UW 4610-A	C3UZ 4209-C					
C4AW 4210-A	WAB 4610-A	C4AZ 4209-L					
C4AW 4210-B	C4AW 4610-A	C4AZ 4209-B					
C4AW 4210-B	C4AW 4610-A	C4AZ 4209-M					
C4AW 4210-C	C4AW 4610-B	C4AZ 4209-C					
C4AW 4210-C	C4AW 4610-B	C4AZ 4209-N					
C4AW 4210-D	C4AW 4610-C	C3AZ 4209-H					
C4AW 4210-E	C4AW 4610-D	C4AZ 4209-E					

4209 KIT - DIFFERENTIAL GEAR and PINION - continued

RING GEAR and PINION IDENTIFICATION CHART LISTED NUMERICALLY BY STAMPED NUMBER ON RING GEAR

IDENTIFICATION NUMBER		RING GEAR & PINION PART NUMBER	REPLACED BY	IDENTIFICATION NUMBER		RING GEAR & PINION PART NUMBER	REPLACED BY
RING GEAR	PINION			RING GEAR	PINION		
C4AW 4210-E	C4AW 4610-D	C4AZ 4209-P	C4AZ 4209-AA	WAB 4210-A	C1TW 4610-A	C1TW 4209-A	B7AZ 4209-K
C4AW 4210-F	C4AW 4610-E	C4AZ 4209-R	C4AZ 4209-AB	WAB 4210-B	WAB 4610-C	WAB 4209-J	C4AZ 4209-C
C4AW 4210-G	C4AW 4610-F	C4AZ 4209-S	C4AZ 4209-AC	WAB 4210-C	WAB 4610-E	WAB 4209-H	C3UZ 4209-C
C4AW 4210-H	C4AW 4610-G	C4AZ 4209-T	C4AZ 4209-AD	WAB 4210-D	WAB 4610-F	WAB 4209-G	C4AZ 4209-E
C4AW 4210-J	C4AW 4610-H	C4AZ 4209-U	C4AZ 4209-AE	WAB 4210-E	WAB 4610-G	WAB 4209-F	C4AZ 4209-AB
				WAB 4210-F	WAB 4610-H	WAB 4209-E	C4AZ 4209-AC
C4DW 4210-A	C4DW 4610-A	C4DZ 4209-D		WAB 4210-G	WAB 4610-K	WAB 4209-D	C4AZ 4209-AC
				WAB 4210-H	WAB 4610-J	WAB 4209-C	C4AZ 4209-AE
C4OW 4210-A	C3OW 4610-A	C3OZ 4209-A	C3OZ 4209-D	WAB 4210-J	WAB 4610-H	WAB 4209-C	C4AZ 4209-AE
C4OW 4210-A	C4OW 4610-A	C4OZ 4209-D	C4OZ 4209-K	WAB 4210-K	WAB 4610-D	WAB 4209-K	C4AZ 4209-B
C4OW 4210-B	C4OW 4610-B	C4OZ 4209-H					
C4OW 4210-C	C4OW 4610-C	C4OZ 4209-J		WAC 4210-A	WAS 4610-A	B7A 4209-D	B7AZ 4209-L
C4OW 4210-D	C3OW 4610-A	C3OZ 4209-C	C3OZ 4209-D	WAC 4210-A	C1AW 4610-C	C1AZ 4209-C	B7AZ 4209-L
				WAC 4210-B	WAM 4610-D	B7A 4209-E	B7AZ 4209-J
WAA 4210-A	WAM 4610-C	B7A 4209-A	B7AZ 4209-H	WAC 4210-B	C1AW 4610-D	C1AZ 4209-D	B7AZ 4209-J
WAA 4210-A	C1SW 4610-A	C1SZ 4209-A	B7AZ 4209-H				
WAA 4210-A	C2AW 4610-S	B7AZ 4209-H		WAL 4210-B	WAM 4610-B	B8E 4209-A	C0AZ 4209-E
WAA 4210-A	C2AW 4610-S	B7AZ 4209-M		WAL 4210-B	C1AW 4610-A	C1AZ 4209-A	C0AZ 4209-E
WAA 4210-B	WAB 4610-A	B7A 4209-B	C0AZ 4209-E				
WAA 4210-B	C1AW 4610-B	C1AZ 4209-B	C0AZ 4209-E	WAM 4210-A	WAM 4610-A	B8A 4209-E	B8AZ 4209-C
				WAM 4210-B	WAM 4610-B	B8A 4209-F	B8AZ 4209-C
WAB 4210-A	WAR 4610-C	B7A 4209-C	B7AZ 4209-K	WAR 4210-B	WAR 4610-D	B8A 4209-D	C0AZ 4209-E

YEAR	MODEL	AXLE IDENTIFICATION	PART NUMBER	QTY.	RATIO	GEAR SIZE	NO. of TEETH GEAR/PINION	REMARKS
60	A, S		B7AZ 4209-H	1	3.70	8 3/4"	37 10	
61	A, S		B7AZ 4209-M	1	3.70	8 3/4"	37 10	
60/	A, B, S		C0AZ 4209-E	1	3.00	9"	39 13	
60/	A, B, S		B8AZ 4209-C	1	3.25	9"	39 12	
60/	A, B, S		B7AZ 4209-L	1	3.50	9"	35 10	
					3.56			
60/	A, B, S-NOTE 2		B7AZ 4209-J	1	3.89	9"	35 9	
60/	A, B, S		B7AZ 4209-K	1	4.11	9"	37 9	
64/	A(8 cyl. 427)		C3AZ 4209-H	1	4.44	9"	40 9	
63	A(8 cyl. 427)-NOTES 1 & 2		C3UZ 4209-C	1	4.57	9"	32 7	
64/	A(high performance engine)-		C4AZ 4209-L	1	3.10	9"	31 10	
60/63	includes lubricant for		C4AZ 4209-B	1	3.40	9"	34 10	
64/	service installation only		C4AZ 4209-M	1	3.40	9"	34 10	
60/63			C4AZ 4209-C	1	4.33	9"	39 9	
64/			C4AZ 4209-N	1	4.33	9"	39 9	
64/			C4AZ 4209-E	1	4.71	9"	33 7	
60/			C4AZ 4209-AB	1	4.86	9"	34 7	
60/			C4AZ 4209-AC	1	5.14	9"	36 7	
60/			C4AZ 4209-AD	1	5.43	9"	38 7	
60/			C4AZ 4209-AE	1	5.67	9"	34 6	
61/	B, X		C1DZ 4209-Y	1	3.20	7 1/4"	32 10	
61/	X(6 cyl.)		C1DZ 4209-Z	1	3.50	7 1/4"	35 10	
62/	B, X		C4OZ 4209-K	1	2.79	8"	39 14	
					2.80	7 3/4"		
62/	B, X		C4OZ 4209-H	1	3.00	8"	39 13	
62/	B, X		C4DZ 4209-D	1	3.25	8"	39 12	
62/	B, X		C4OZ 4209-J	1	3.50	8"	35 10	
62/64	B(71)		C3OZ 4209-D	1	3.80	8"	38 10	
60	X(58A, 64)" Before 2/22/60"		C0DZ 4209-A	1	3.10	6 3/4"	31 10	3.435" MTG.DISTANCE
60	X(58A, 64)" From 2/22/60"		C0DZ 4209-AC	1	3.10	6 3/4"	31 10	3.435" MTG.DISTANCE
60	X(58A, 64)		C1DZ 4209-J	1	3.10	6 3/4"	31 10	3.560" MTG.DISTANCE
61/64	X(58A, 64)-6 cyl.		C1DZ 4209-AA	1	3.10	6 3/4"	31 10	3.560" MTG.DISTANCE

Note 1 - For high performance duty use 5 1/2 pints C2AZ 19580-D lubricant

Note 2 - When using this kit to replace one with 1/2"-20 holes-use C3AZ 4216-A bolt

▲ For service 8" gears replace 7 3/4" production gears and 9" gears replace 8 3/4" gears

FORD CAR PARTS

SECTION 40

105

YEAR	MODEL	AXLE IDENTIFICATION	PART NUMBER	QTY.	RATIO	GEAR		NO. OF TEETH		REMARKS
						SIZE	NO.	GEAR	PINION	
4209 KIT - DIFFERENTIAL GEAR and PINION - continued										
60	X	"Before 2/28/60"	C1DZ 4209-N	1	3.50	6 3/4"	35	10		
60	X	"From 2/28/60"	C1DZ 4209-V	1	3.50	6 3/4"	35	10	3.435" MTG.DISTANCE	
60/64	X (58A, 64)-6 cyl.		C1DZ 4209-T	1	3.50	6 3/4"	35	10	3.560" MTG.DISTANCE	
60/64	X (66A, 71, 78)-6 cyl.		C1DZ 4209-U	1	3.50	7"	35	10		
60/64	X (66A, 71, 78)-6 cyl.		CIUZ 4209-D	1	4.00	7"	36	9		
YEAR	MODEL	AXLE IDENTIFICATION	PART NUMBER	QTY.	DESCRIPTION					
60/	A, S, X		371518-S(MM180)	1	Locknut (pinion flange to pinion)-3/4"-20					
60	X		351521-S(XX237)	1	Washer-flat-3/4"					
60/	A, B, S, X		356214-S8(XX162)		Washer-flat-29/64"					
62	A (8 cyl. 406)		352887-S(XX182)	10	Washer-1/2"					
60/	A (except locking axle)		372487-S(BB395)	10	Bolt (gear to case)-7/16"-20 x 15/16"-locking					
60/	B, X (8 cyl.)			10						
60/	A, B, S, X-locking axles		350627-S(BB432)	10	Bolt(gear to case)-7/16"-20 x 1 1/8"-self locking					
60/	X		372768-S(BB437)	8	Bolt (gear to case)-3/8"-24 x 3/4"-locking					
64/	X		379237-S(BB394A)	8	Bolt(ring gear to case)-3/8"-24 x 1.17"-locking					
62	A (8 cyl. 406)		376749-S(BB396)	10	Bolt (gear to case)-1/2"-20 x .98"locking					
4211 SHAFT - DIFFERENTIAL PINION										
60/	A, B, S, X(7 3/4", 8", 8 3/4", 9" ring gear)		*B7A 4211-A	1	3/4" dia. -4 29/32" long-R/B B7AZ 4211-A (6-68)					
60/	B, X (6 3/4", 7", 7 1/4" ring gear)		C0DZ 4211-A	1	5/8" dia. -4 3/64" long					
60/	A (with locking axle)		352506-S(NN115)	1	Pin (shaft lock)-1/4"-1 1/2"					
60/	A, B, S, X		359475-S(NN116)	1or3	Pin (shaft lock)-1/4" x 1 3/4"					
60/	B, X (6 cyl.)		353909-S8	1	Pin (shaft lock)-3/16" x 1 1/2"					
4211 KIT - DIFFERENTIAL PINION SHAFT										
61/	A, B, S (4 pinion diff.)-8 3/4", 9" ring gear		C1AZ 4211-A	1	Consists of - 1-WAB 44205-A seat 2-WAB 44207-A shaft 3-359475-S pin					
60/	A, B, S, X(2 pinion diff.)-7 3/4", 8", 8 3/4", 9" ring gear		B7AZ 4211-A	1	Consists of -1-C9AW 4211-A shaft & 1-305105-S pin					
61/	B, X (4 pinion diff.)-6 3/4", 7", 7 1/4" ring gear		C1DZ 4211-A	1	Consists of - 2-C1DW 4419-A shaft 1-C1DW 4420-A seat 3-305110-S pin					
4214 SPRING - DIFFERENTIAL CLUTCH										
60/64	A, S	"Before 1/2/64"	B9A 4214-A	2	Locking axle					
64/	A, S	"From 1/2/64"	C4AZ 4214-A	1	Locking axle (exc.torque sensitive)-separate carrier					
64/	B, X			1						
4215 KIT - DIFFERENTIAL SHAFT PINION										
60/61	A, S	"Before 12/19/60"	B7A 4215-B	1	Consists of - 2-WAA 4215-C pinion 2-B7A 4230-A washer					
61/	A, B, S, X (7 3/4", 8", 8 3/4", 9" ring gear)-"From 12/19/60"		C1AZ 4215-B	1or2	Consists of - 2-C1AW 4215-B pinion 2-B7A 4230-A washer Use with non-locking axles					
61/	A, B, S, X (7 3/4", 8", 8 3/4", 9" ring gear)		C1AZ 4215-C	1or2	Consists of - 2-C1AW 4215-C pinion 2- B7A 4230-A washer Use with locking axles					
61/	B, X(6 3/4", 7", 7 1/4" ring gear)		C0DZ 4215-C	1	Consists of -2-C0DW 4215-C pinion 2-C0DW 4230-C washer Use with 2 piece case					
60/61	X		C0DZ 4215-B	1	Consists of -2-C0DW 4215-B pinion 2-C0DW 4230-A washer -use with C0DZ 4236-B kit for 1 piece case					
4216 BOLT - DIFFERENTIAL GEAR TO CASE										
62/	A (8 cyl. 406, 427)		C3AZ 4216-A	10	To attach ring gear with 7/16" holes to case with 1/2" holes					
4221 CONE and ROLLER ASSY. - DIFFERENTIAL BEARING										
60/	A, B, S, X		B7A 4221-A	2	1 5/8" I. D. -stamped LM 501349 (med.)-Also used as front wheel bearing					
60/	A, B, S		B7A 4221-B	2	1 25/32" I. D. -stamped LM 603049(larger)-Also used as front wheel bearing					
61/	B, X		C1OW 4221-A	2	1 1/2" I. D. -stamped LM 29749 (small)					
60	X		B7C 1201-A	2	Stamped LM 48548					

▲ For service 8" gears replace 7 3/4" production gears and 9" gears replace 8 3/4" gears

YEAR	MODEL	AXLE IDENTIFICATION	PART NUMBER	QTY.	DESCRIPTION
4222 CUP - DIFFERENTIAL BEARING					
60/	A, B, S, X		B7A 4222-A	2	2 57/64" O. D. -stamped LM 501310 (medium)-Also used as frt. wheel brg. cup
60/	A, B, S		B7A 4222-B	2	3 1/16" O. D. -stamped LM603011(large)-Also used as front wheel brg. cup
61/	B, X		CIUW 4222-A	2	2 9/16" O. D. -stamped 29710 (small)
60	X		B7C 1202-A	2	Stamped LM 48510
4228 WASHER - DIFFERENTIAL SIDE GEAR THRUST					
60/	A, B, S, X (7 3/4", 8", 8 1/2", 8 3/4", 9" ring gear)		C2OW 4228-A	2	1 25/32" I. D. -2 7/8" O. D. -.031" thick
60/	B, X (6 3/4", 7", 7 1/4" ring gear)		C0DW 4228-A	2	1 25/64" I. D. -2 1/4" O. D. -.032" thick
4230 WASHER - DIFFERENTIAL PINION SHAFT THRUST					
60/	A, B, S, X (7 3/4", 8", 8 3/4", 9" ring gear)		B7AZ 4230-A	2or4	25/32" I. D. -1 33/64" O. D. -.032" thick - phosphate coated
60/64	X (6 3/4", 7", 7 1/4" ring gear)-except Taxi		C0DW 4230-A	2	21/32" I. D. -1 9/32" O. D. -.031" thick-phosphate coated-black
60/	B, X (6 3/4", 7", 7 1/4" ring gear)-including Taxi		C0DW 4230-C	2	21/32" I. D. -1 11/32" O. D. -.032" thick-cadmium plate - White
4234-5 SHAFT and BEARING ASSY. - REAR AXLE					
60/64	A		● C0AZ 4234-A	1	R.H. - 28 splines-32 13/64" long
			● C0AZ 4235-A	1	L.H. -27 27/32" long
60/ 62	A (For Special Duty Performance Only)-8 cyl. 352, 390		▲ C0AW 4234-D	1	R.H. - 28 splines-32 29/64" long
			* ▲ C0AZ 4235-C	1	L.H.-28 3/32" long -Not replaced
63/64	A	WBT, WBV	▲ C2SZ 4234-C	1	R. H. -28 splines-32 1/4" long
			▲ C2SZ 4234-D	1	L. H. -27 15/16" long
63/64	A (8 cyl. 427)	WCN	▲ C3AZ 4234-A	1	R.H.-31 splines-32 1/8" long
			▲ C3AZ 4234-B	1	L.H. - 27 3/4" long
62/	B	WCL, WCU, WDK	● C2OZ 4234-A	1	R. H. -28 splines-30 1/8" long
			● C2OZ 4235-A	1	L. H. -26 5/64" long
60	S		▲ B9S 4234-A	1	R.H.-28 spline-30 23/32" long
			▲ B9S 4235-A	1	L.H.-26 23/64" long
61	S		● C0AZ 4234-A	1	R. H. -28 splines-32 13/64" long
			● C0AZ 4235-A	1	L. H. -27 27/32" long
62/	S	WCD, WDE	▲ C2SZ 4234-C	1	R. H. -28 splines-32 1/4" long
			▲ C2SZ 4234-D	1	L.H. -27 15/16" long
60/61	X (S/D, S/W, 66A, Taxi)		◇ C0DW 4234-B	1	R.H.-23 splines -28 31/32" long
			◇ C0DZ 4235-B	1	L.H. -25 29/64" long
60/61	X (58A, 64A)		□ C0DW 4234-C	1	R.H.-23 splines-28 31/32" long
			□ C0DZ 4235-A	1	L.H. -25 29/64" long
61/62	X (S/D, S/W, 66A)		◇ C1DW 4234-A	1	R.H.-24 splines-29 11/64" long-4 studs
61/62	X (Taxi)-6 cyl. 144 & S/T			1	R.H.
			◇ C1DZ 4234-A	1	L.H. -25 43/64" long
61/62	X (58A, 64)		□ C1DW 4234-B	1	R.H.-24 splines-28 31/32" long-4 studs
			□ C1DZ 4234-B	1	L.H. -25 29/64" long
63	X	WBW	□ C3DZ 4234-C	1	L.H.-24 splines-25 43/64" long
			□ C3DZ 4234-D	1	R. H. -29 11/64" long
63	X	WBY	◇ C3DZ 4234-E	1	R.H.-24 splines-29 11/64" long
			◇ C3DZ 4234-F	1	L.H. -25 43/64" long
63	X	WCS	● C3DZ 4234-A	1	R.H.-28 splines-29 17/64" long
			● C3DZ 4234-B	1	L.H. -25 7/32" long
64/	X	WCY	◇ C4DZ 4234-A	1	R.H.-24 splines -29 15/16" long
			◇ C4DZ 4234-B	1	L. H. -26 7/16" long
64/	X	WCZ, WDJ	● C2OZ 4234-A	1	R. H. -28 splines-30 1/8" long
			● C2OZ 4235-A	1	L. H. -26 5/64" long
60/	A, S, X		356080-S32(MM270)	4or6	Spring nut (shaft to brake drum)-1/2"
4236 GEAR - DIFFERENTIAL SIDE					
60/61	A, S (with locking axle)- "Before 12/19/60"		B9A 4236-B	1	28 splines-4 omitted-No hub - use with 1 pc. WAA 4236-C included in B7A 4236-B Kit
61/	A, B, S, X(with locking axle)-except 7 1/4", "From 12/19/60"		C2AZ 4236-B	1	28 splines-4 omitted-no hub-use with 1 pc. C2AW 4236-A included in C2AZ 4236-A kit

▲ Includes C1SZ 1225-B bearing
● Includes B7AZ 1225-A bearing

◇ Includes C0DZ 1225-C bearing
□ Includes C0DZ 1225-A bearing

FORD CAR PARTS

YEAR	MODEL	AXLE IDENTIFICATION	PART NUMBER	QTY.	DESCRIPTION
4236-7 KIT - DIFFERENTIAL SIDE GEAR					
60/61	A, S "Before 12/19/60"		B7A 4236-B	1	28 splines-4 omitted-with hub Consists of -2-WAA 4236-C Gear (use 1 pc. for locking axle) 2-C9OZ 4228-A Washer
61/	A, B, S, X (exc. 6 3/4", 7", 7 1/4", ring gear)- "From 12/19/60"		C2AZ 4236-A	1	28 splines-4 omitted-with hub Consists of 2-C2AW 4236-A Gear (use 1 pc. for locking axle) 2-C9OZ 4228-A Washer
64/	A (8 cyl. 427)- Exc. locking axle		C4AZ 4236-A	1	31 splines-4 omitted-with hub Consists of - 2-C4AW 4236-A Gear 2-C9OZ 4228-A Washer
61/	B, X (6 3/4", 7", 7 1/4" ring gear)		C1DZ 4236-C	1	24 splines - Consists of 2 - C4DZ 4236-A Gear 2 - C0DW 4228-A Washer
60/61	X (with 3.10 to 1 ratio)		C0DZ 4236-B	1	23 splines-Use w/C0DZ 4215-B kit - Consists of - 2-C0DW 4236-B Gear & 2-C0DW 4228-A Washer for 1 pc. case
60/61	X (except 3.10 to 1 ratio)		C0DZ 4236-C	1	23 splines - Consists of - 2-C0DW 4236-C Gear 2-C0DW 4228-A Washer
61/63	X (with 3.10 to 1 ratio)		C1DZ 4236-A	1	24 splines - Consists of - 2-C1DW 4236-A Gear 2-C0DW 4228-A Washer
4298 BRACKET - DRIVING PINION BEARING RETAINER - Also refer to Group 4730					
60/	A (except 8 cyl. 427 with 1330 U Joint)	WBT, WBS, WCN	C0AW 4298-A	1	Bracket
63/64	A (with 1330 U/joint)	WBV, WCN	C3AZ 4298-B	1	Bracket
63/64	B (8 cyl. 260)-S/T	WCL	C3OZ 4298-A	1	Bracket-use with torsional damper axle flange
63/	B(8 cyl. 289-4/B carb.)	WCU	C3OZ 4298-C	1	Bracket
4346 SCREW - COVER TO HOUSING					
60/	A, B, X		C7AZ 4346-A	10	3/8"-16 x 5/8" locking
4347 BOLT - DIFFERENTIAL CARRIER TO REAR AXLE HOUSING					
60/	A, S		C1AW 4347-A	10	3/8"-24 x 1 9/16"
62/	B, X		34445-S7-8(M80)	10	Locknut-3/8"-24
			353667-S(XX156)	5	Washer-flat (copper)-25/64"
4529 'U' BOLT - UNIVERSAL JOINT					
61/	A, B		C1AZ 4529-A	2	5/16"-24 for 1 1/8" bearing caps
63/	X(8 cyl.)			2	
60/	S, Police Interceptor		C8UZ 4529-A	2	5/16"-24-for 1 1/16" bearing caps
60/	A			2	
60/	X(6 cyl.)		C0DD 4529-A	2	1/4"-28 for 1" bearing caps
			33798-S7-8(M62)		Nut-5/16"-24
			34806-S7(X64)		Lockwasher-5/16"
			33796-S7(M61)		Nut-1/4"-28
			34805-S8(X62)		Lockwasher-1/4"

4602 DRIVE SHAFT and RELATED PARTS

Drive Shafts Group 4602, Universal Joints Group 4635 and Knuckle & Plug Assemblies Group 4841 are cataloged in chart form under group numbers 4602. The drive shafts and related parts are listed by model years and within the model years designated by car line. The various codes designating the universal joints and knuckle & plug assemblies are explained below. Identification charts showing the various dimensions of universal joints and knuckle & plug assemblies appear under Groups 4635 and 4841.

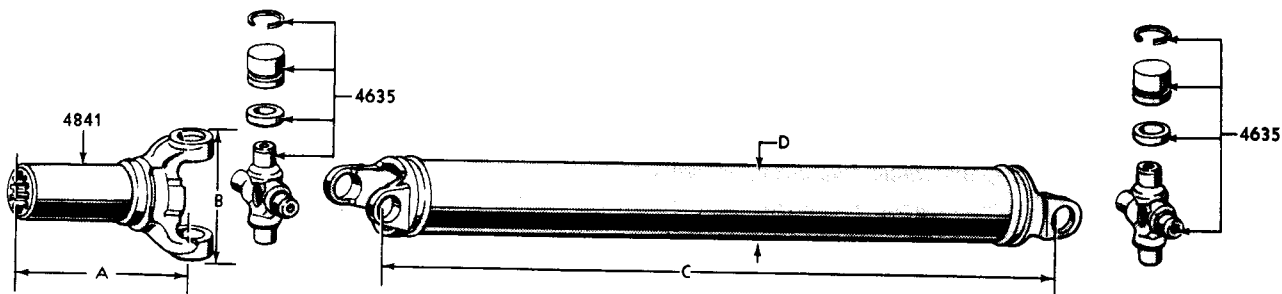

P-3895

Universal Joint Codes used throughout the chart apply to part numbers as indicated
Also refer to Group 4635 for Universal Joint Identification Chart

CODE	PART NO.	T Y P E	CODE	PART NO.	T Y P E
F	C0DZ 4635-A	Mechanics-1100-2 21/32" span	T	C3AZ 4635-E	Cleveland Steel-1310-3 15/32" span
K	C2SZ 4635-A	Cleveland Steel-1310-1330-3 15/32" x 3 5/8" span	V	C3AZ 4635-F	Cleveland Steel-1310-3 15/32" span
L	C3DZ 4635-A	Mechanics or SACO-1100-2 21/32"span	Y	C3AZ 4635-G	Cleveland Steel-1330-3 5/8" span
R	C3AZ 4635-C	Spicer or Ford-1260-3 15/32" span	Z	C3AZ 4635-H	Cleveland Steel-1330-3 5/8" span
S	C3AZ 4635-D	Spicer or Ford-1260-3 15/32" span	AD	C4SZ 4635-B	Spicer-1330-3 5/8" span

Knuckle and Plug Codes used throughout the chart apply to part numbers as indicated
Also refer to Group 4841 for Knuckle and Plug Identification Chart

CODE	PART NO.	A	B	NO. SPLINES	REPLACED BY	CODE	PART NO.	A	B	NO. SPLINES	REPLACED BY
8	C0AA 4841-A	7 15/64"	3 1/4"	28		26	C3AZ 4841-G	8 7/32"	3 7/8"	28	
11	C1DD 4841-D	7 3/4"	2 15/32"	25		27	C4SZ 4841-A	7 1/2"	3 7/8"	31	
16	C0SS 4841-A	7 5/16"	3 1/4"	31		28	C1UZ 4841-A	5 29/32"	2 15/32"	25	
18	C3AZ 4841-A	8 7/32"	3 1/2"	31		32	C3DZ 4841-A	8 1/4"	3 1/2"	25	
20	C3AZ 4841-C	8 13/64"	3 15/32"	28		33	C2OZ 4841-B	7 5/8"	3 15/32"	25	
23	C3AZ 4841-D	8 3/32"	3 1/2"	28		43	C7SZ 4841-A	8 5/32"	3 29/32"	31	
24	C3AZ 4841-E	8 7/32"	3 21/32"	28							

YEAR	MODEL	TRANSMISSION	IDENTIFICATION	UNIV. JOINT CODE		KNUCKLE & PLUG CODE	DRIVE SHAFT		PART NUMBER
				FRONT	REAR		C LENGTH	D DIAMETER	
- A - 1960 - 1964									
60	A (Spicer type)		No color	R	R	23	56 17/32"	2 3/4"	ΔC0AA 4602-F
60	Taxicab(6 cyl. & 8 cyl. 292)	F/M/2, O/D, S/T							
60	Taxicab (8 cyl. 352)	S/T							
60	A (8 cyl. 352) -4/B carb.	O/D, C/M	No color	R	R	18	56 17/32"	2 3/4"	★C0AA 4602-D
60	P/I (8 cyl. 352)	S/T, O/D							
60/61	A, Taxicab (6 cyl. 223)(8 cyl. 292)	S/T, F/M/2,							
61	A (6 cyl. & 8 cyl. 292)	All	1 Green band	R	S	23	56 1/2"	2 3/4"	C2AZ 4602-F
61	A (8 cyl. 352-2/B carb.)	C/M							
61	A (P/I)-8 cyl. 352	S/T							
61	A (8 cyl. 390 & Special)-4 & 6/B carb.	S/T	1 Pink band	R	V	8	56 35/64"	3"	C1AA 4602-L

● See above for universal joint and knuckle & plug codes

Δ Attached with "U" bolts

4602 DRIVE SHAFT and RELATED PARTS - continued

YEAR 19—	MODEL	TRANSMISSION	IDENTIFICATION	●UNIV. JOINT CODE			DRIVE SHAFT		PART NUMBER
				FRONT	REAR	● KNUCKLE & PLUG CODE	C	D	
							LENGTH	DIAMETER	
- A - 1960 - 1964									
61/62	A (6 cyl. 223)	O/D, F/M/2	1 Green band	R	S	23	56 1/2"	2 3/4"	C2AZ 4602-F
61/62	A (8 cyl. 292)	O/D, C/M							
61/62	A (8 cyl. 352)	F/M/2, S/T, C/M							
61/62	A (8 cyl. 352, 390)	3 & 4 S/T, F/M/2	Rubber insulated-lub fitted	R	V	8	56 35/64"	3"	C2AZ 4602-E
62/64	A (8 cyl. 352)	O/D	1 White band	T	V	16	56 5/8"	3"	C2AZ 4602-H
61/62	A (8 cyl. 390-4/B & 6/B carb.)	O/D, C/M							
62	A (6 cyl. 223)	S/T	Rubber insulated-1 Pink band	R	V	23	56 1/2"	3"	C2AZ 4602-G
62	A (8 cyl. 292)	S/T, F/M/2							
62	A (8 cyl. 352)	F/M/2, C/M	1 Green band	R	S	23	56 1/2"	2 3/4"	C2AZ 4602-F
62	A, Taxicab (6 cyl. 223 & 8 cyl. 292)	F/M/2, S/T, C/M							
62	A (8 cyl. 390, 406)	3 or 4 S/T	Rubber insulated-lub fitted 1 Yellow & 1 Red band	R	V	8	56 35/64"	3"	C2AZ 4602-E
62	A (8 cyl. 390)	O/D, C/M	1 White band	T	V	16	56 5/8"	3"	C2AZ 4602-H
62	A (8 cyl. 406)	O/D							
62	A (8 cyl. 390)-4 & 6/B carb.	All							
62	A (8 cyl. 390 & Special)- 4 & 6/B carb.	S/T	1 Pink band	R	V	8	56 35/64"	3"	C1AA 4602-L
63	A (exc. 65B, 76B)(6 cyl. 223)	F/M/2	1 Yellow & 1 White band	R	S	23	56 5/8"	2 3/4"	C3AZ 4602-H
63	A (exc. 65B, 76B)(8 cyl. 260, 289)	C/M							
63	A (65B, 76B)(8 cyl. 260)	F/M/2							
63	A (8 cyl. 352) "Before 4/15/63"	C/M	1 White & 1 Red band-plug fitted-Rubber insulated	T	V	20	56 11/32"	3"	C3AZ 4602-B
63	A (8 cyl. 390, 406)- "Before 6/17/63"	3 or 4 S/T							
63	A (8 cyl. 352) "Before 4/15/63"	O/D	Rubber insulated 1 White, 2 Yellow bands	T	V	23	56 19/64"	3"	C3AZ 4602-F
63	A (8 cyl. 390) "Before 6/17/63"	O/D							
64	A (6 cyl. 223)	3/S/T, O/D, C/M	Cardboard lined-1 White & 1 Charcoal band	R	S	23	59 51/64"	3 1/4"	C4AZ 4602-A
64	A (8 cyl. 289)	3 or 4 S/T, C/M, O/D							
63/64	A (8 cyl. 260, 289)-(6 cyl. 223)	3/S/T, C/M, O/D, F/M/2	Cardboard lined-1 Orange	R	S	23	56 5/8"	2 3/4"	C4AZ 4602-B
63/64	A (Taxi) (6 cyl. 223)	3/S/T, F/M/2	1 Green band						
63/64	A (8 cyl. 352) "From 4/15/63"	3 or 4 S/T, C/M	Cardboard lined-1 Red & 1 Light Green band	T	V	23	56.30"	3"	C3AZ 4602-Y
63/64	A (8 cyl. 352) "From 4/15/63"	O/D	1 Green & White band - plug fitted	T	V	18	56 7/16"	3"	C3AZ 4602-C
63	A (8 cyl. 390) "Before 6/17/63"	C/M	Units with "A" following numerical numbers on axle model tag						
63	A (8 cyl. 390) "Before 6/17/63"	3 or 4 S/T	1 White & 1 Red band-plug fitted-Rubber insulated	T	V	20	56 11/32"	3"	C3AZ 4602-B
63/64	A (8 cyl. 390 4/B) "From 6/17/63"	O/D	Plug fitted-rubber insulated 1 White & 1 Yellow band	Y	Z	43	56 1/4"	3"	C3AZ 4602-T
64	A, (A P/I)-except 57C, 63C, 76B (8 cyl. 390)	O/D							
63/64	A, (A P/I)-8 cyl. 390 4/B "From 6/3/63"	C/M	Plug fitted-1 White & 1 Silver band	Y	Z	43	56.30"	3"	C3AZ 4602-M
63/64	A, (A P/I)-8 cyl. 390 4/B "From 6/17/63"	3 or 4 S/T	Plug fitted-rubber insulated 1 White & 1 Red band	Y	Z	26	56 1/4"	3"	C3AZ 4602-S
63	A (8 cyl. 406) "Before 6/17/63"	4 S/T	1 White & 1 Red band-plug fitted-Rubber insulated	T	V	20	56 11/32"	3"	C3AZ 4602-B
63	A Special (8 cyl. 427) "Before 6/3/63"	3 or 4 S/T	1 Red & 1 Tan band	T	V	24	57.30"	3"	C3AZ 4602-N

● Refer to page 108 for universal joint and knuckle & plug codes

4602 DRIVE SHAFT and RELATED PARTS - continued

YEAR 19__	MODEL	TRANSMISSION	IDENTIFICATION	UNIV. JOINT CODE		*KNUCKLE & PLUG CODE	DRIVE SHAFT		PART NUMBER
				FRONT	REAR		C LENGTH	D DIAMETER	
- A - 1960 - 1964									
63/64	A Special (8 cyl. 427) "From 6/3/63"	3 or 4 S/T	Plug fitted, cardboard lined-1 White & 1 Blue band	Y	Z	26	56 3/16"	3"	C3AZ 4602-V
63	A (except 71, 76, 65B) 8 cyl. 427 "Before 6/3/63"	O/D	Plug fitted, cardboard lined, 1 White & 1 Tan band	T	V	43	57 3/16"	3"	C3AZ 4602-R
63	A (8 cyl. 427) "From 6/3/63"	O/D	Plug fitted cardboard	Y	Z	43	56 3/16"	3"	C3AZ 4602-U
64	A(54,57B,62,63B,76B)-8 cyl.427	O/D	lined,1 White & 1 Silver band						
- B - 1962-1964									
62/63	B (6 cyl. 170)-H,D clutch	S/T	Lub fitted-rubber insulated 1 Red & 1 Orange band	R	S	32	57 1/8"	3"	C3OZ 4602-A
62/63	B (8 cyl. 221)	S/T,O/D, F/M/2	Plug fitted-rubber insulated 1 Orange band	R	S	33	58"	3"	C3OZ 4602-B
62/63	B (8 cyl. 260)	F, M/2, O/D, 4/S/T							
64	B (8 cyl. 260,289)(exc. 116" W/B)	O/D, F/M/2							
62	B (8 cyl. 221, 260)	All							
63	B (8 cyl. 260)	3/S/T	Plug fitted-rubber insulated	R	S	33	57 3/8"	3"	C3OZ 4602-D
64	B (8 cyl. 260, 289)(except 116" W/B)	3/S/T	1 Yellow band						
63	B (6 cyl. 170)	S/T,F/M/2	Plug fitted-rubber insulated	R	S	33	58"	3"	C3OZ 4602-B
63/64	B (6 cyl. 200)(except 116" W/B)	F/M/2	1 Red band						
64	B (6 cyl. 170)(except 116" W/B)	3/S/T							
62	B (6 cyl. 170, 8 cyl. 221)	All							
63/64	B (except S/W)(8 cyl. 289 4/B) (except 116" W/B)	3/S/T	1 Orange & 1 Blue band- plug fitted-cardboard lined	R	S	23	53 39/64"	3"	C3OZ 4602-H
63/64	B (except S/W)(8 cyl. 289 4/B) (except 116" W/B)	4/S/T	1 Orange & 1 Yellow band plug fitted-cardboard lined	R	S	23	55 39/64"	3"	C3OZ 4602-K
63/64	B (except S/W)(8 cyl. 289 4/B) (except 116" W/B)	O/D, C/M	2 Silver bands-plug fitted-cardboard lined	R	S	23	57 3/64"	3"	C3OZ 4602-J
64	B (8 cyl. 260, 289) (except 116" W/B)	F/M/3, C4	Rubber insulated	R	S	23	58 13/64"	3"	C4OZ 4602-A
64	B (8 cyl. 289-2/B carb.) (except 116" W/B)	4/S/T	Rubber insulated 2 White bands	R	S	23	56 5/8"	3"	C4OZ 4602-B
64	B(65)(6 cyl. 170)(116" W/B- except with H/D clutch)	3/S/T	1 Red & 1 Lavender band	R	S	33	58 1/2"	3"	C4OZ 4602-C
64	B(65)(8 cyl. 260, 289 2/B)- 116" W/B	3/S/T,O/D							
64	B(65)(6 cyl. 220)-116" W/B	F/M/2							
64	B(65)(8 cyl. 260, 289 2/B)- 116" W/B	F/M/2							
64	E(65)(8 cyl. 260, 289 2/B)- 116" W/B	C4	Pink & vert. paint bands	R	S	23	58 1/2"	3"	C6OZ 4602-T
64	B(65)(6 cyl. 170)-116" W/B with H/D clutch	3/S/T	Rubber insulated	R	S	32	57 21/32"	3"	C4OZ 4602-E
64	B(65)(8 cyl. 289 4/B)-116" W/B	4/S/T		R	S	23	56 7/64"	3"	C4OZ 4602-F
64	B(65)(8 cyl. 289 4/B)-116" W/B	C4		R	S	23	57 35/64"	3"	C4OZ 4602-G
64	B(65)(8 cyl. 289 2/B)-116" W/B	4/S/T	Rubber insulated	R	S	23	57 1/8"	3"	C4OZ 4602-H
- S - 1960-1964									
60	S (8 cyl. 352)	All		R	R	18	52"	3"	B8S 4602-A
60	S (8 cyl. 430)	C/M		R	R	18			B8S 4602-B
61	S	All		T	T	18	51 45/64"	2 3/4"	C1SS 4602-C
62	S	All	Rubber insulated-lub fitted	A	B	18	51 11/16"		C2SZ 4602-B
63	S	All	Plug fitted-rubber insulated	A	D	27	52 1/8"	3"	C3SZ 4602-A
64	S	All	Plug fitted-rubber insulated	A	D	27	52 1/8"	3"	C4SZ 4602-B
- X - 1960 - 1964									
60	X (58A, 64A)	F/M/2	1 Light Blue band	F	F	11	55 1/2"	2 1/2"	*ΔC0DD 4602-B R/B C1DD 4602-R
60/62	X (S/D, S/W, 66A)	S/T, F/M/2	1 Green band	F	F	11	55 15/32"	2 3/4"	*C1DD 4602-E R/B C1DD 4602-R

• Refer to page 108 for universal joint and knuckle & plug codes

4602 DRIVE SHAFT and RELATED PARTS - continued

DRIVE SHAFT CHART

YEAR 19__	MODEL	TRANSMISSION	IDENTIFICATION	UNIV. JOINT CODE		*KNUCKLE & PLUG CODE	DRIVE SHAFT		PART NUMBER
				FRONT	REAR		C LENGTH	D DIAMETER	
- X - 1960-1964									
60/62	X (58A, 64A)-6 cyl. 144	S/T, F/M/2	1 Orange band	F	F	11	55 15/32"	2 1/2"	C1DD 4602-R
61/62	X (6 cyl. 170)	3 or 4 S/T, F/M/2	2 Orange bands	F	F	11	54 19/32"	2 3/4"	C1DD 4602-N
61/62	X (58A, 64A, B)-6 cyl. 170	S/T	1 Red Band	F	F	11	54 19/32"	2 1/2"	*C1DD 4602-A R/B C1DD 4602-N
62	X (58A, 64A, B)-6 cyl. 144	S/T	1 Red band	F	F	11	55 15/32"	2 1/2"	*C1DD 4602-G R/B C1DD 4602-R
62	X (58A, 64A, B)-6 cyl. 144	F/M/2	1 Light Blue band	F	F	11	55 15/32"	2 1/2"	*C1DD 4602-H R/B C1DD 4602-R
62	X (58, 62, 64) (6 cyl. 144)	4 SPD.	3 White or 3 Yellow bands	F	F	11	53 1/3"	2 1/2"	*C2DZ 4602-A
62	X (58A, 64A, B)-6 cyl. 170	F/M/2	1 Light Blue band	F	F	11	54 19/32"	2 1/2"	*C1DD 4602-B R/B C1DD 4602-N
62	X (58, 62, 64) (6 cyl. 170)	4 SPD.	3 Green or 3 Black bands	F	F	11	52 1/2"	2 1/2"	*C2DZ 4602-B
62	X (S/D, S/W, 66A)-6 cyl. 170	F/M/2	2 Green bands	F	F	11	54 19/32"	2 1/2"	*C1DD 4602-C R/B C1DD 4602-N
63/64	X (6 cyl. 170) X (6 cyl. 200) X (66, 71, 78)(6 cyl. 144, 170) X (66, 71, 78)(6 cyl. 170, 200)	3/S/T, F/M/2 F/M/2 3/S/T F/M/2	2 Chrome Yellow bands cardboard lined	L	L	28	54 17/32"	2 3/4"	C3DZ 4602-A
63/64	X (6 cyl. 144)	3/S/T, F/M/2	1 Chrome Yellow band cardboard lined	L	L	28	55 13/32"	2 3/4"	C3DZ 4602-B
63/64	X (6 cyl. 170)	4 S/T	3 Black bands	L	L	28	52 17/32"	2 1/2"	C3DZ 4602-C
63/64	X (6 cyl. 144)	4 S/T	3 White bands	L	L	28	53 21/64"	2 1/2"	C3DZ 4602-D
63/64	X (8 cvL)	3 or 4 S/T, F/M/2	1 Orange & 1 Silver or 1 Orange & 1 Light Blue Band cardboard lined	R	S	32	52 11/32"	2 3/4"	C3DZ 4602-G

YEAR	MODEL	DESCRIPTION	QTY.	PART NUMBER
60/	A, S, B	Fitting (spider lubricator)-1/4"-28	2	87907-S8 (I-3)
63	A, B	Fitting (drive shaft lubricator)	2	
60	A (except Taxicab & P/T)	Screw-set (u/joint plug)-1/4"-28 x 3/8"	1	355312-S34 (UU36)
62	X	Nut-1/4"-28	4	33796-S7 (M61)
62/	X	Lockwasher-1/4"	4	34805-S8 (X62)
62	S	Lockwasher-5/16"	4	34806-S7 (X64)
62	S	Nut (driveshaft to flange)-5/16"-24	4	33798-S8 (M62)
63/	A, B, X	Nut (drive shaft to flange)-5/16"-24	4	372990-S8 (MM169B)
		Plug-1/4"-28 hex.	2	374714-S8 (PP35A)

YEAR	MODEL	AXLE IDENTIFICATION	PART NUMBER	QTY.	DESCRIPTION
4614 RETAINER & BEARING CUP ASSY. - DRIVING PINION BEARING					
60/62	A		C2AZ 4614-B	1	Includes 2 pcs. B7A 4616-A-Mounts to 5" hole in carrier housing
63/	A(2 pinion diff.)			1	
60/	S(8 3/4" & 9" ring gear)			1	
63/	B(8 cyl. 289 4/B special)			1	
63/	A (4 pinion diff.)		C3AZ 4614-A	1	Includes 1-B7A 4616-A, 1-TBAA 4616-A mounts to 5" hole in carrier housing
62/	B (exc. 8 cyl. 260 S/T, 289 4/B special)		C6OZ 4614-A	1	Includes (2) C0DW 4616-A- mounts to 4 1/4" hole in carrier housing
63/	X			1	
63	B (8 cyl. 260)-S/T		C3OZ 4614-A	1	Includes 2 pcs. C0DW 4616-A- mounts to 4 1/4" hole in carrier housing
60/	A, B, S		42999-S(B253)	5	Bolt (retainer to differential carrier)-3/8"-16 x 1 1/8" self locking

• Refer to page 108 for universal joint and knuckle & plug codes

YEAR	MODEL	AXLE IDENTIFICATION	PART NUMBER	QTY.	DESCRIPTION
4616 CUP - DRIVING PINION BEARING					
60/	A, S(8 3/4" 9" ring gear)		B7A 4616-A	2	Front & rear-Stamped M88010
60/62	A			1	Rear
63/	A (2 pinion diff.)			1	Rear
63/	B (8 3/4" & 9" ring gear)			2	Front & rear
60/	S (8 3/4" & 9" ring gear)			2	Front & rear
63/	A (4 pinion diff.)		TBAA 4616-A	1	Rear-stamped HM89410
64/	B, X(7 1/4" ring gear)			1	Rear
60/	B, X(6 3/4", 7" & 7 1/4" ring gear)		C0DW 4616-A	1	Front-stamped M86610
62/	B, X(7 3/4" & 8" ring gear)			2	Front & rear
60/64	B, X(6 3/4" & 7" ring gear)		C0DW 4628-A	1	Rear-Stamped HM88610
62/63	B, X (7 1/4" ring gear)			1	Rear
4621 CONE and ROLLER ASSY. - DRIVING PINION BEARING					
60/	A(8 3/4" & 9" ring gear)		B7A 4621-A	2	Front & rear-stamped M88048
60/62	A			1	Rear
63/	A (2 pinion diff.)			1	Rear
63/	B (8 3/4" & 9" ring gear)			2	Front & rear
60/	B, X(6 3/4", 7" & 7 1/4" ring gear)		C0DW 4621-A	1	Front-stamped M86649
62/	B, X(7 3/4" & 9 ring gear)			2	Front & rear
63/	A(4 pinion diff.)		TBAA 4621-A	1	Rear-stamped HM 89443
64/	B, X(7 1/4" ring gear)		C1DZ 4630-A	1	Rear-stamped HM89446
60/64	B, X(6 3/4" & 7" ring gear)		C0DW 4630-A	1	Rear-stamped HM88649
62/63	B, X(7 1/4" ring gear)			1	Rear
4625 BEARING ASSY. - DRIVING PINION PILOT					
60/	A, B, S(8 3/4" & 9" ring gear)		C2AZ 4625-B	1, 10" I. D. -1.85" O. D. -21/32" thick	
62/	B, X(7 3/4" & 8" ring gear)		C2OZ 4625-B	1 3/4" I. D. -1 1/4" O. D. -5/8" thick	
4627 RETAINER - DRIVING PINION PILOT BEARING					
60/	A, B, S(8 3/4" & 9" ring gear)		B7AZ 4627-A	1	
62/	B, X(7 3/4" & 8 ring gear)		C2OZ 4627-A	1	1 1/4" O. D. -7/8" I. D. -12 tabs
4628 CUP - DRIVING PINION BEARING - REAR - Refer to Group 4616					
4630 CONE and ROLLER ASSY. - DRIVING PINION BEARING - REAR - Refer to Group 4621					
4635 KIT - UNIVERSAL JOINT					

UNIVERSAL JOINT IDENTIFICATION CHART

Universal joints, Group 4635 are cataloged also by year and model on the pages following the Identification Chart
 Universal joints are also listed by code in Group 4602

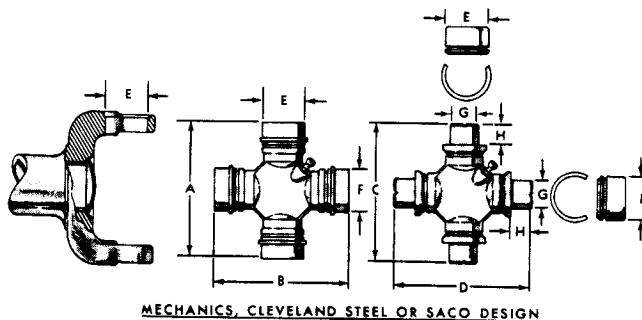
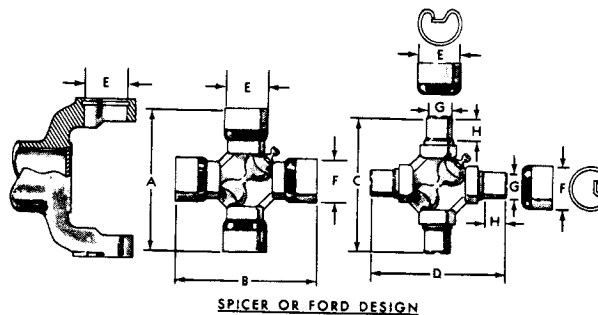

4635 KIT - UNIVERSAL JOINT - continued - See Identification Chart at the beginning of this group											
NUJ CODE	PART NUMBER	INDUSTRY DESIGNATION	A	B	C	D	E	F	G	H	DESIGN
E	B6TZ 4635-A	1310	3 15/32"	3 15/32"	3"	3"	1 1/16"	1 1/16"	21/32"	11/16"	Spicer or Ford
F	C0DZ 4635-A	1100	2 21/32"	2 21/32"	2 1/4"	2 1/4"	1"	1"	37/64"	9/16"	Mechanics
K	C2SZ 4635-A	1330-1310	3 5/8"	3 15/32"	3 3/8"	3"	1 1/16"	1 1/16"	21/32"	17/32"	Cleveland
L	C3DZ 4635-A	1100	2 21/32"	2 21/32"	2 1/4"	2 1/4"	1"	1"	37/64"	37/64"	Mech., or Saco
R	C3AZ 4635-C	1260	3 15/32"	3 15/32"	2 31/32"	2 31/32"	1 1/16"	1 1/16"	19/32"	9/16"	Spicer or Ford
S	C3AZ 4635-D	1260	3 15/32"	3 15/32"	2 31/32"	2 31/32"	1 1/16"	1 1/8"	19/32"	9/16"	Spicer or Ford
T	C3AZ 4635-E	1310	3 15/32"	3 15/32"	3"	3"	1 1/16"	1 1/16"	11/16"	17/32"	Cleveland
V	C3AZ 4635-F	1310	3 15/32"	3 15/32"	3"	3"	1 1/16"	1 1/8"	11/16"	17/32"	Cleveland
Y	C3AZ 4635-G	1330	3 5/8"	3 5/8"	3 13/32"	3 13/32"	1 1/16"	1 1/16"	11/16"	19/32"	Cleveland
Z	C3AZ 4635-H	1330	3 5/8"	3 5/8"	3 13/32"	3 13/32"	1 1/16"	1 1/8"	11/16"	19/32"	Cleveland
ADC4SZ	4635-B	1330	3 5/8"	3 5/8"	3 3/8"	3 3/8"	1 1/16"	1 1/16"	21/32"	35/64"	Spicer

MODEL	ENGINE		TRANSMISSION	RESTRICTIONS	VENDOR		PART NUMBER	
	CYL.	C.I.D.			NAME	TYPE	FRONT	REAR
1960								
A(exc. Special)	6&8	All	All		Ford or Spicer	1260	C3AZ 4635-C	C3AZ 4635-C
A(Special)	8	352	All		Ford or Spicer	1310	B6TZ 4635-A	B6TZ 4635-A
S	8	All	All		Ford or Spicer	1260	C3AZ 4635-C	C3AZ 4635-C
X	6	All	All		Mechanics	1100	C0DZ 4635-A	C0DZ 4635-A
1961								
A	6&8	223,292, 352	All	2 3/4" dia. drive shaft	Ford or Spicer	1260	C3AZ 4635-C	C3AZ 4635-D
A	8	352, 390	S/T, F/M/2	3" dia. drive shaft	Ford or Spicer Cleveland	1260 1310	C3AZ 4635-C	C3AZ 4635-F
A	8	352, 390	O/D, C/M	3" dia. drive shaft	Cleveland	1310	C3AZ 4635-E	C3AZ 4635-F
S	8	All	All		Cleveland	1310	C3AZ 4635-E	C3AZ 4635-E
X	6	All	All		Mechanics	1100	C0DZ 4635-A	C0DZ 4635-A
1962								
A	6&8	223, 292	All	2 3/4" dia. drive shaft	Ford or Spicer	1260	C3AZ 4635-C	C3AZ 4635-D
A	6&8	223, 292	All	3" dia. drive shaft	Ford or Spicer Cleveland	1260 1310	C3AZ 4635-C	C3AZ 4635-F
A	8	352	C/M, F/M/2, S/T	2 3/4" dia. drive shaft	Ford or Spicer	1260	C3AZ 4635-C	C3AZ 4635-D
A	8	352	F/M/2, S/T	3" dia. drive shaft	Ford or Spicer Cleveland	1260 1310	C3AZ 4635-C	C3AZ 4635-F
A	8	352	O/D	3" dia. drive shaft	Cleveland	1310	C3AZ 4635-E	C3AZ 4635-F
A	8	390, 406	F/M/2, S/T		Ford or Spicer Cleveland	1260 1310	C3AZ 4635-C	C3AZ 4635-F
A	8	390, 406	C/M, O/D		Cleveland	1310	C3AZ 4635-E	C3AZ 4635-F
B	6&8	All	All		Ford or Spicer	1260	C3AZ 4635-C	C3AZ 4635-D
S	8	All	All		Spicer Cleveland	1330 1310	C4SZ 4635-B	C2SZ 4635-A
X	6	All	All		Mechanics	1100	C0DZ 4635-A	C0DZ 4635-A
1963								
A	6&8	223, 260, 289	All		Ford or Spicer	1260	C3AZ 4635-C	C3AZ 4635-D
A	8	352	All		Cleveland	1310	C3AZ 4635-E	C3AZ 4635-F
A - "BEFORE 6/3/63"	8	390	C/M	*A-3 15/32", B-3 15/32"	Cleveland	1310	C3AZ 4635-E	C3AZ 4635-F
A	8	406	All					
A - "FROM 6/3/63"	8	390	C/M	*A-3 5/8", B-3 5/8"	Cleveland	1330	C3AZ 4635-G	C3AZ 4635-H
A - "BEFORE 6/17/63"	8	390	S/T, O/D	*A-3 15/32", B-3 15/32"	Cleveland	1310	C3AZ 4635-E	C3AZ 4635-F
A - "FROM 6/17/63"	8	390	S/T, O/D	*A-3 5/8", B-3 5/8"	Cleveland	1330	C3AZ 4635-G	C3AZ 4635-H
A - "BEFORE 6/3/63"	8	427	All	*A-3 15/32", B-3 15/32"	Cleveland	1310	C3AZ 4635-E	C3AZ 4635-F
A - "FROM 6/3/63"	8	427	All	*A-3 5/8", B-3 5/8"	Cleveland	1330	C3AZ 4635-G	C3AZ 4635-H
B	6&8	All	All		Ford or Spicer	1260	C3AZ 4635-C	C3AZ 4635-D
S	8	All	All		Spicer	1330	C4SZ 4635-B	C4SZ 4635-B
X	6	All	All		Mechanics or Saco	1100	C3DZ 4635-A	C3DZ 4635-A
X	8	All	All		Ford or Spicer	1260	C3AZ 4635-C	C3AZ 4635-D

* Refer to Universal Joint Identification Chart

4635 KIT - UNIVERSAL JOINT - continued - See Identification Chart at the beginning of this group

MODEL	ENGINE		TRANSMISSION	RESTRICTIONS	VENDOR		PART NUMBER	
	CYL.	C.I.D.			NAME	*TYPE	FRONT	REAR
1964								
A	6&8	223,289,352	All		Ford or Spicer	1260	C3AZ 4635-C	C3AZ 4635-D
A	8	390	C/M	*A-3 15/32", B-3 15/32"	Cleveland	1310	C3AZ 4635-E	C3AZ 4635-F
A	8	390,427	All	*A-3 5/8", B-3 5/8"	Cleveland	1330	C3AZ 4635-G	C3AZ 4635-H
B	6&8	All	All		Ford or Spicer	1260	C3AZ 4635-C	C3AZ 4635-D
S	8	All	All		Spicer	1330	C4SZ 4635-B	C4SZ 4635-B
X	6	All	All		Mechanics or Saco	1100	C3DZ 4635-A	C3DZ 4635-A
X	8	All	All		Ford or Spicer	1260	C3AZ 4635-C	C3AZ 4635-D

YEAR	MODEL	AXLE IDENTIFICATION	PART NUMBER	QTY.	DESCRIPTION
4662 SPACER - DRIVING PINION BEARING - Selective fit					
60/	A, B, S(8 3/4" & 9" ring gear)		B7A 4662-A	1	1.315" I. D. -.480" long(collapsible)
64/	A, S(8 cyl. 390, 427)-9" ring gear		C4AZ 4662-A	AR	1.313" I. D. -1.625" O. D. -.466" long
			C4AZ 4662-B	AR	(solid) .468" long
			C4AZ 4662-C	AR	.470" long
			C4AZ 4662-D	AR	.472" long
			C4AZ 4662-E	AR	.474" long
			C4AZ 4662-F	AR	.476" long
			C4AZ 4662-L	AR	.477" long
			C4AZ 4662-G	AR	.478" long
			C4AZ 4662-M	AR	.479" long
64/	A, S(8 cyl. 390, 427)-9" ring gear		C4AZ 4662-H	AR	1.313" I. D. -1.625" O. D. -.480" long
			C4AZ 4662-N	AR	(solid) .481" long
			C4AZ 4662-J	AR	.482" long
			C4AZ 4662-P	AR	.483" long
			C4AZ 4662-K	AR	.484" long
			C4AZ 4662-R	AR	.485" long
			C6AZ 4662-A	AR	.486" long
			C6AZ 4662-B	AR	.487" long
			C6AZ 4662-C	AR	.488" long
			C6AZ 4662-D	AR	.489" long
			C6AZ 4662-E	AR	.490" long
60	X (with 6 3/4" ring gear) "Before 2/11/60"		C1DW 4662-E	1	1.512" long-mounting distance 3.435"-collapsible
60	X (with 6 3/4" & 7" ring gears) "From 2/11/60"		C1DW 4662-F	1	1.387" long-mounting distance 3.56"-collapsible
61/64	X(6 3/4" & 7" ring gears)		C3DZ 4662-A	1	1.387" long
62/	B, X(7 3/4" & 8" ring gears)		C2OW 4662-A	1	.480" long-1.21" I. D. -collapsible
62/	B, X(7 1/4" ring gears)		C3DZ 4662-B	1	2.014" long
4663 SHIM - DRIVING PINION BEARING - Supplied in 4209 Kit					
60	X (6 cyl.)		CODW 4663-BB	1	1/8" thick-use with pinion gear when required by variation in mtg. distance
4669 "O" RING - DRIVING PINION BEARING RETAINER					
60/	A, B, S(8 3/4" & 9" ring gears)		B7A 4669-A	1	4 3/4" I. D.
62/	B, X(7 3/4" & 8 ring gears)		C2OZ 4669-A	1	4" I. D.
4670 SLINGER - DRIVING PINION SHAFT OIL					
60/	A, B, S(8 3/4", 9" ring gears)		C3AZ 4670-A	1	2 5/8" O. D. -1 5/16" I. D. -.020" thick
62/	B, X(7 3/4" & 8" ring gears)		C3OZ 4670-A	1	2 15/32" O. D. -1 3/16" I. D. -.020" thick

* Refer to Universal Joint Identification Chart

YEAR	MODEL	AXLE IDENTIFICATION	PART NUMBER	QTY.	DESCRIPTION
4676 SEAL ASSY. - DRIVING PINION OIL					
60/62	A, S (exc. 8 cyl. 406)		B8A 4676-B	1	1 13/16" I. D. -3" O. D. leather
60/	A (8 cyl. 406, 427)		C3AZ 4676-A	1	1 13/16" I. D. -3" O. D. -1/2" thick - silicone rubber
62/	B(exc. 8 cyl. 289 Spec.)		C2OZ 4676-B	1	1 13/16" I. D. -2 5/8" O. D. -1/2" thick
63/	X (8 cyl.)			1	
63/	A, S(exc. 8 cyl. 406, 427)		C2AZ 4676-A	1	1 13/16" I. D. -3" O. D. -1/2" thick-
63/	B(8 cyl. 289 Spec.)			1	single lip neoprene seal
60/	X(6 cyl.)		C1UZ 4676-C	1	1 21/32" I. D. -2 5/8" O. D. -29/64" thick
4706 PACKING - UNIVERSAL JOINT					
60	A, X		B5A 4706-A	8	.572"/.582" I. D. cork
4730 BUMPER - REAR AXLE - Also refer to Groups 4298 and 5783					
60/62	A		C1AZ 4730-A	1	Differential carrier
63/64	A(exc. S/W)(8 cyl. 390, 427)		C3AZ 4730-B	1	Differential carrier
63/64	A (exc. 8 cyl. 390, 427)		C4AZ 4730-A	1	Carrier (not used with Fairlane extension)-stud-.58" long
64	A (6 cyl. 223-8 cyl. 289)-3/S/T & F/M/3		C4AZ 4730-B	1	Carrier (used with Fairlane extension)-stud-.83" long
60/	X		C0DZ 4730-A	3	Axle
63/	X(6 cyl.)			3	Axle to frame & carrier
64/	X(8 cyl. 260 289)			lor3	Differential carrier
63/	X (8 cyl.)		C3DZ 4730-A	2	Axle
63/	X (8 cyl.)		C3DZ 4730-B	1	Differential carrier
63/	S		C1VV 4730-B	2	Axle
60/64	A			2	Frame
62/	B		C2OZ 4730-B	2	Axle
62/	B(exc. 8 cyl. 260, 3/S/T, O/D)		C3OZ 4730-A	1	Differential carrier
63	B (8 cyl. 260, 3/S/T, O/D)		C3OZ 4730-B	1	Differential carrier
63/	B (exc. 71)(8 cyl. 289 4/B)		C3OZ 4730-D	1	Differential carrier
4731 BRACKET - REAR AXLE BUMPER - Also refer to Group 5784					
62	B		*C2OZ 4731-A	1	Axle-center-Not replaced (1-69)
63	B (6 cyl. 170)(8 cyl. 221)-S/T, O/D, F/M/2			1	
63/	B (8 cyl. 260, 289)-S/T, O/D, F/M/2			1	
64	B (6 cyl. 170)-S/T			1	
64	B (6 cyl. 200)-F/M/2			1	
63	B (8 cyl. 260 & S/T)		C3OZ 4731-A	1	Axle
63	S		C3SZ 4731-A	2	Axle
64/	S		C4SZ 4731-A	2	Axle
63	X (8 cyl.)		C3DZ 4731-E	2	Differential
64/	X		C4DZ 4731-A	2	Differential
63	X (54, 62, 63, 76)		C3DZ 4731-F	1	Spring-R.H.
60/	X (54, 58A, 62, 64)			1	Axle-outer-R.H.
			C3DZ 4731-G	1	Spring-L.H.
				1	Axle-outer-L.H.
63	X (59, 66, 71, 78)		C3DZ 4731-H	1	Axle bumper mounting-outer-R.H.
60/	X (66A, S/W, S/D)			1	Axle-R.H.
			C3DZ 4731-J	1	Axle bumper mounting-outer-L.H.
				1	Axle-L.H.
61/	S		373139-S(BB163)		Bolt (rear axle bumper to underbody)-3/8"-16 x 2 3/4"
			44727-S8(X24)		Washer-3/8"
63	B		33800-S8(M63)	1	Nut (bracket to underbody)-3/8"-24
63	B		354202-S8(BB359)	1	Bolt (bracket to underbody)-3/8" - 24 x 4 1/2"
62/	X		*41209-S8	AR	Screw (bracket to rail)-5/16"-18 x 3/4" tapping

SECTION 46**4841 KNUCKLE and PLUGS ASSY. - UNIVERSAL JOINT****UNIVERSAL JOINT KNUCKLE and PLUG ASSY. IDENTIFICATION CHART**

Universal joint knuckle and plug assemblies, Group 4841 are cataloged also by year and model in the Drive Shaft and Universal Joint Chart under Group 4602.

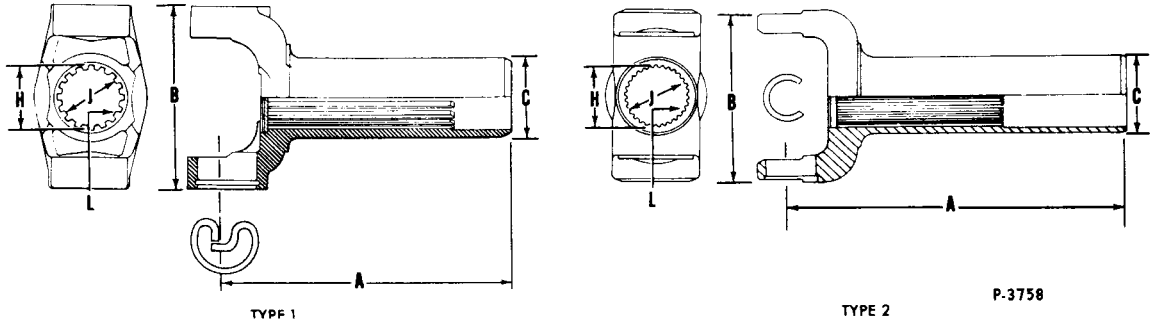

PART NUMBER	DRIVE SHAFT CHART CODE	TYPE 1			TYPE 2			TYPE
		A	B	C	H	J	L	
COAA 4841-A	8	7 15/64"	3 1/4"	1 1/2"	1 13/64"	1 3/32"	28	2
C1DD 4841-D	11	7 3/4"	2 15/32"	1 3/8"	1 7/64"	63/64"	25	2
COSS 4841-A	16	7 5/16"	3 1/4"	1 11/16"	1 3/8"	1 17/64"	31	2
C3AZ 4841-A	18	8 7/32"	3 1/2"	1 11/16"	1 3/8"	1 17/64"	31	1
C3AZ 4841-C	20	8 13/64"	3 15/32"	1 1/2"	1 13/64"	1 3/32"	28	1
C3AZ 4841-D	23	8 3/32"	3 1/2"	1 1/2"	1 7/32"	1 3/32"	28	1
C3AZ 4841-E	24	8 7/32"	3 21/32"	1 1/2"	1 13/64"	1 3/32"	28	2
C3AZ 4841-G	26	8 7/32"	3 7/8"	1 1/2"	1 7/32"	1 3/32"	28	1
C4SZ 4841-A	27	7 1/2"	3 7/8"	1 11/16"	1 3/8"	1 17/64"	31	1
CIUZ 4841-A	28	5 29/32"	2 15/32"	1 3/8"	1 7/64"	63/64"	25	2
C3DZ 4841-A	32	8 1/4"	3 1/2"	1 1/2"	1 7/64"	63/64"	25	1
C2OZ 4841-B	33	7 5/8"	3 15/32"	1 1/2"	1 7/64"	63/64"	25	1
C7SZ 4841-A	43	8 5/32"	3 29/32"	1 11/16"	1 3/8"	1 17/64"	31	1

4851 FLANGE ASSY. - UNIVERSAL JOINT - AXLE END

UNIVERSAL JOINT FLANGE IDENTIFICATION CHART

Universal joint flanges, Group 4851 are also listed by year and model following the identification chart.

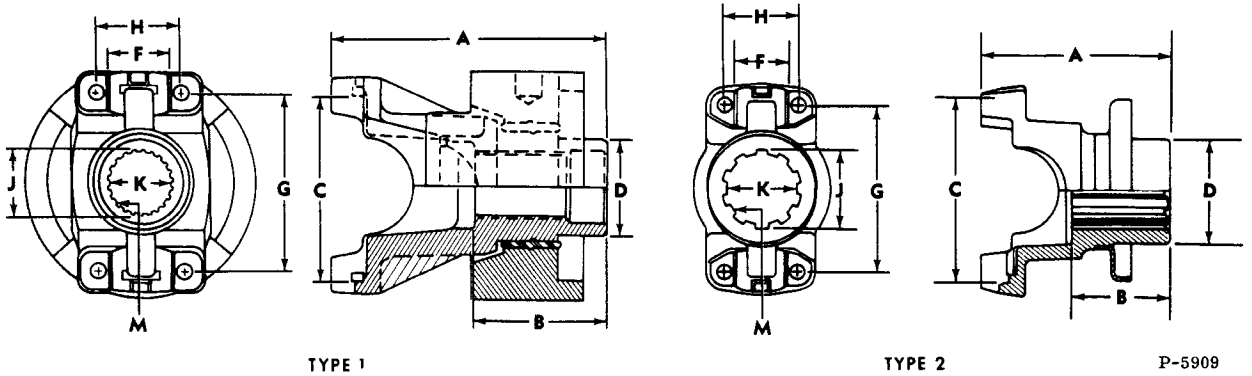

TYPE	A	B	C	D	E	F	G	H	J	K	M	PART NUMBER
1	4 25/32"	2 9/64"	3 5/8"	1 13/16"		1 1/8"	3 5/16"	1 37/64"	1 15/64"	1 9/64"	28	C5AZ 4851-C
1	5 1/16"	2 27/64"	3 7/32"	1 13/16"		1 1/8"	2 31/32"	1 37/64"	1 15/64"	1 9/64"	28	C3AZ 4851-D
1	5 1/16"	2 27/64"	3 7/32"	1 13/16"		1 1/8"	2 31/32"	1 37/64"	1 15/64"	1 9/64"	28	C3AZ 4851-E
1	5 1/16"	2 27/64"	3 5/8"	1 13/16"		1 1/8"	3 5/16"	1 37/64"	1 15/64"	1 9/64"	28	C3AZ 4851-F
2	2 15/16"	1 15/64"		1 21/32"		1"	2 7/32"	1 23/64"	1 1/64"	15/16"	23	C2DZ 4851-A
2	4 1/16"	2 27/64"	3 15/64"	1 13/16"		1 1/16"	2 29/32"	1 13/32"	1 15/64"	1 9/64"	28	C3TZ 4851-A
2	4 1/16"	2 27/64"	3 5/8"	1 13/16"		1 1/16"	3 5/16"	1 13/32"	1 15/64"	1 9/64"	28	C3SZ 4851-A
2	4 13/32"	2 5/8"	3 7/32"	1 13/16"		1 1/8"	2 31/32"	1 37/64"	1 7/64"	1 1/64"	25	C3OZ 4851-A
2	4 25/32"	2 9/64"	3 5/8"	1 13/16"		1 1/8"	3 5/16"	1 37/64"	1 15/64"	1 9/64"	28	C4AZ 4851-A
2	5 1/16"	1 25/64"	3 7/32"	1 13/16"		1 1/8"	2 31/32"	1 37/64"	1 7/32"	1 9/64"	28	C3AZ 4851-H
2	5 1/16"	2 27/64"	3 7/32"	1 13/16"		1 1/16"	2 29/32"	1 13/32"	1 7/32"	1 9/64"	28	C0AW 4851-B
2	5 1/16"	2 27/64"	3 7/32"	1 13/16"		1 1/8"	2 31/32"	1 37/64"	1 15/64"	1 9/64"	28	C3AZ 4851-L
2	5 1/16"	2 27/64"	3 5/8"	1 13/16"		1 1/8"	3 5/16"	1 37/64"	1 15/64"	1 9/64"	28	C3AZ 4851-M
2	5 1/16"	2 5/8"	3 7/32"	1 13/16"		1 1/8"	2 31/32"	1 37/64"	1 7/64"	1 1/64"	25	C3OZ 4851-C

4851 FLANGE ASSY. - UNIVERSAL JOINT - AXLE END - continued

YEAR	MODEL	AXLE IDENTIFICATION	PART NUMBER	QTY.	DESCRIPTION
60	A		C0AW 4851-B	1	#1260
61/	A(8 3/4" ring gear)		C3AZ 4851-L	1	#1310-without torsional damper
63	A(8 cyl.427)-extra heavy duty		C3AZ 4851-H	1	#1330-without torsional damper
63	A(8 cyl. 427)	WCN-CX	C3SZ 4851-A	1	#1330-without torsional damper
63/	A(9" ring gear)		C3AZ 4851-M	1	#1330-without torsional damper
63/64	A(8 cyl. 427) "Before 3/9/64"	WCN (exc. CX)		1	
64/	A(8 cyl. 427) "From 3/9/64"		C4AZ 4851-A	1	#1330-without torsional damper
63/64	A(6 cyl.223, 8 cyl. 260, 289, 352-3/S, 4/S, O/D)		C3AZ 4851-E	1	#1310-with torsional damper
63/64	A(8 cyl.260-F/M/2), (8 cyl.289-F/M/2, C/M), (8 cyl.390-3/S, 4/S, O/D)		C3AZ 4851-D	1	#1310-with torsional damper
63/64	A "Before 4/6/64"		C3AZ 4851-F	1	#1330-with torsional damper
64/	A "From 4/6/64"		C5AZ 4851-C	1	#1330-with torsional damper stamped "C" or "E"
62	B		C3OZ 4851-A	1	#1260-without torsional damper
63/	B	WCL (exc. E, F, G), WDK,		1	
63	B	WCL-E, F, G	C3OZ 4851-C	1	#1260-without torsional damper
63/	B	WCU	C3AZ 4851-L	1	#1310-without torsional damper
60/62	S thru Serial No. 103500		C3TZ 4851-A	1	#1330-without torsional damper
62	S From Ser. No. 103501		C3SZ 4851-A	1	#1330-without torsional damper
63/	S	WCD, WDE		1	
60/	X(6 cyl.)		C2DZ 4851-A	1	#1100
62/	X(8 cyl.)	WCS, WCZ, WDJ	C3OZ 4851-A	1	#1260
60/	A, S, X		371518-S(MM180)	1	Locknut u/jt. (flange to pinion)-3/4"-20
60/	A, S		351588-S(XX227)	1	Washer-flat-.77" I. D.
60/	X		351521-S(XX237)	1	Washer-flat-3/4" I. D.

4859 DEFLECTOR - UNIVERSAL JOINT FLANGE OIL SEAL DUST

60/62	A, S		B8A 4859-A	1	3 27/64" large I. D. x 1 7/8" small I. D.
63/	A, B, S(8 3/4", 9" ring gear)		C3AZ 4859-B	1	3 1/2" large I. D. x 2" small I. D.
63/	B(8 cyl.)	WCL	C3OZ 4859-A	1	3" large I. D. x 2" small I. D.
60/64	X (6 cyl.) "Before 7/15/64"	WCY-E, F, L, M, N, AB, AC, AD	C2DW 4859-A	1	2 5/8" large I. D. x 1 11/16" small I. D.
64/	X (6 cyl.) "From 7/15/64"	WCY-E, F, L, M, N, AB, AC, AD,	C2DZ 4859-A	1	3 9/16" large I. D. x 1 11/16" small I. D.
63/	X (8 cyl.)	WCZ-A, E, F, G, WDJ-A, B, C, E,	C3OZ 4859-A	1	3" large I. D. x 2" small I. D.

4880 KIT - LOCKING DIFFERENTIAL

60/	A, S(8 3/4" & 9" ring gears)		B9AZ 4880-B	1	Use with 2 pinion medium bearing differential & 28 spline shaft-for original installation or pinion replacement also use C1AZ 4215-C
-----	------------------------------	--	-------------	---	--

Consists of

1-B9A 4159-A	Lubricator	1-352506-S	Pin	4-B9AZ 4947-A	Clutch plate
1-C4AZ 4204-E	Case	1-C4AZ 4214-A	Spring	10-371246-S	Bolt-7/16"-20
1-C2AW 4236-A	Side gear	3-B9AZ 4945-A	Clutch plate	1-4121	Identification tag
1-C4AZ 4946-A	Hub	1-C2AZ 4236-B	Side gear		

61/	A, B, S(8 3/4" & 9" ring gear)		C1AZ 4880-C	1	Use with 2 or 4 pinion large bearing differential & 28 spline axle shaft-for original installation or pinion replacement also use C1AZ 4215-C
-----	--------------------------------	--	-------------	---	---

Consists of

1-C4AZ 4204-F	Case	1-C2AZ 4236-B	Gear	4-B9AZ 4947-A	Plate
1-C4AZ 4214-A	Spring	3-B9AZ 4945-A	Plate	1-352506-S	Pin
1-C2AW 4236-A	Gear	1-C4AZ 4946-A	Hub	10-371246-S	Bolt
				5 1/2 Pts.	Lubricant

4880 KIT - LOCKING DIFFERENTIAL - continued						
YEAR	MODEL	AXLE IDENTIFICATION	PART NUMBER	QTY.	DESCRIPTION	
63/	A (8 cyl. 427 4/B Special)		C3AZ 4880-B	1	No spin diff. with 31 spline axle shaft	
	Consists of					
	1-C5AZ 4A022-A	Retainer	1-C5AZ 4A233-A	Clutch-Driven	2-C5AZ 4236-A	Gear
	1-C5AZ 4A024-A	Spring	1-C5AZ 4A234-A	Clutch & Ring Assy.	1-C5AZ 4588-A	Hold out ring
	1-C5AZ 4204-A	Case				
64/	B, X(7" & 7 1/4" ring gear)		C4DZ 4880-A	1	With integral carrier	
	Consists of					
	1-C4DZ 4204-A	Case	1-C4DZ 4236-B	Side gear	4-C4DZ 4947-A	Plate
	1-C4DZ 4214-A	Spring	3-C4DZ 4945-A	Plate assy.	1-305086-S	Pin
	1-C4DZ 4236-A	Side gear	1-C4DZ 4946-A	Hub	8-379237-S	BOLT 3/8" .24X1.17"
64/	B, X(7 3/4" & 8" ring gear)		C4OZ 4880-A	1	Use with separate carrier & small diff. bearing-for original installation or pinion replacement also use C1AZ 4215-C	
	Consists of					
	1-C4OZ 4159-A	Lubricator	1-C2AW 4236-A	Side gear	1-C4AZ 4946-A	Hub
	1-C4OZ 4204-A	Case	1-C2AZ 4236-B	Side gear	4-B9AZ 4947-A	Plate
	1-C4AZ 4214-A	Spring	3-B9AZ 4945-A	Plate	1-305105-S	Pin
			10-371246-S	Bolt 7/16"-20		
4891 SNAP RING - UNIVERSAL JOINT SPIDER BEARING RETAINING						
60/	A, B, X		C3AZ 4891-A	AR	1 1/4" Major O.D.	
60/	X		A8AZ 4891-A	8	.918" I.D.	
4945 PLATE ASSY. - DIFFERENTIAL CLUTCH						
60/64	A, S	"Before 1/2/64"		B9AZ 4945-A	2	With locking axle
64/	A, B, S, X	"From 1/2/64"	Exc. WCY, WDV		3	With locking axle
64/	X(6 cyl.)		WCY, WDV	C4DZ 4945-A	3	Locking axle with integral carrier
4946 HUB - DIFFERENTIAL GEAR CLUTCH						
60/64	A, S	"Before 1/2/64"		C1AW 4946-A	1	With locking axle
64/	A, S	"From 1/2/64"		C4AZ 4946-A	1	With locking axle
64/	B, X		Exc. WCY, WDV		1	With locking axle
64/	X(6 cyl.)		WCY, WDV	C4DZ 4946-A	1	Locking axle with integral carrier
4947 PLATE - DIFFERENTIAL GEAR CLUTCH						
60/64	A, S	"Before 1/2/64"		B9AZ 4947-A	3	With locking axle
64/	A, S	"From 1/2/64"			4	With locking axle
64/	B, X		Exc. WCY, WDV		4	With locking axle
64/	X(6 cyl.)		WCY, WDV	C4DZ 4947-A	4	Locking axle with integral carrier
4953 KIT - DIFFERENTIAL - LESS DRIVEN GEAR						
60	A Spec. (8 cyl. 352 4/B)			COAW 4953-A	1	
61	A Spec. (8 cyl. 390 4/B)-with S/T & O/D				1	
	Consists of					
	1-COAW 4204-A	Case	2-WAA 4220-A	Bearing	2-WAA 4236-C	Gear
	1-B7A 4211-A	Shaft	2-B7A 4228-A	Washer	1-WAB 44205-A	Seat
	4-WAA 4215-C	Pinion	4-B7A 4230-A	Washer	2-WAB 44207-A	Shaft
			3-359475-S or 370083-S	Pin		

