

INDEX

Exterior Mouldings Illustrations are arranged by car line in the following order:

- Section A - Ford
- Section B - Fairlane
- Section S - Thunderbird
- Section X - Falcon

FORD (A)

YEAR	MODEL	PAGE	ILLUS. NO.	YEAR	MODEL	PAGE	ILLUS. NO.
60	54, 58, 75	848	P-3044	63	54A, 75	867	P-3950
60	59	849	P-3049	63	54B, 62B	868	P-3951
60	62, 64	850	P-3045	63	62A, 65	869	P-3953
60	63, 76	851	P-3046	63	63, 76	870	P-3956
60	71E, F, H	852	P-3051	63	71A, E, G, H	871	P-3964
60	71G	853	P-3052	63	71B, C	872	P-3965
61	54, 75	854	P-3321	64	54A, 62A	873	P-4264
61	58	855	P-3322	64	54B, E	874	P-4265
61	59	856	P-3324	64	57B, C	875	P-4268
61	62, 65	857	P-3325	64	62B, E	876	P-4270
61	63, 76	858	P-3326	64	63B, C	877	P-4273
61	64	859	P-3327	64	71A, E	878	P-4274
61	71E, F, H	860	P-3330	64	71B, C	879	P-4275
61	71G, J	861	P-3331	64	76	880	P-4277
62	54A, 75	862	P-3689	64	Optional body side moulding	881	P-4428
62	54B, 62B	863	P-3690				
62	62A, 65, 76	864	P-3691				
62	71A, E	865	P-3694				
62	71B, C, D	866	P-3695				

FAIRLANE (B)

62	54	882	P-3755	64	54A, 62A	889	P-4278
62	62	883	P-3756	64	54B, 62B	890	P-4279
63	54A, 62A	884	P-3966	64	65	891	P-4282
63	54B, 62B, 65	885	P-3967	64	71B	892	P-4284
63	71B	886	P-3972	64	71D	893	P-4285
63	71D	887	P-4011				
63	71E, G	888	P-3973				

THUNDERBIRD (S)

60	All	894	P-3163	62, 63	76	897	P-3757
61	All	895	P-3320	64, 65	63	898	P-4301
62, 63	63	896	P-3987	64, 65	76	899	P-4302

FALCON (X)

60	58, 64	900	P-3054	63	54A, B	910	P-3961
60	59, 71	901	P-3198	63	59, 71A, B	911	P-3964
60, 63	66	902	P-3754	63	62A, B	912	P-4140
61	58, 64	903	P-3335	63	63, 76	913	P-3981
61	59, 71	904	P-3339	63	71C, D	914	P-3985
61, 63	78	905	P-3753	64	54A, D, 62A, D	915	P-4288
62	58, 64A	906	P-3747	64	54B, 62B	916	P-4287
62	59, 71A	907	P-3750	64	59, 71A, B	917	P-4297
62	62, 64C	908	P-3751	64	63, 76	918	P-4293
62	71B	909	P-3752	64	71C	919	P-4298
				64	54A, D, 62A, D	920	P-4296
				64	54B, 62B	921	P-4296
				64	59, 71A, B	922	P-4760
				64	63, 76	922	P-4295
				64	71C		
				64	66A, B		
				64	66G, H		
				64	78		

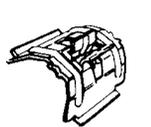
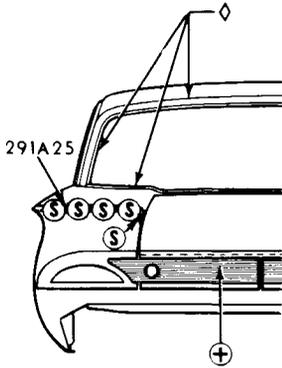
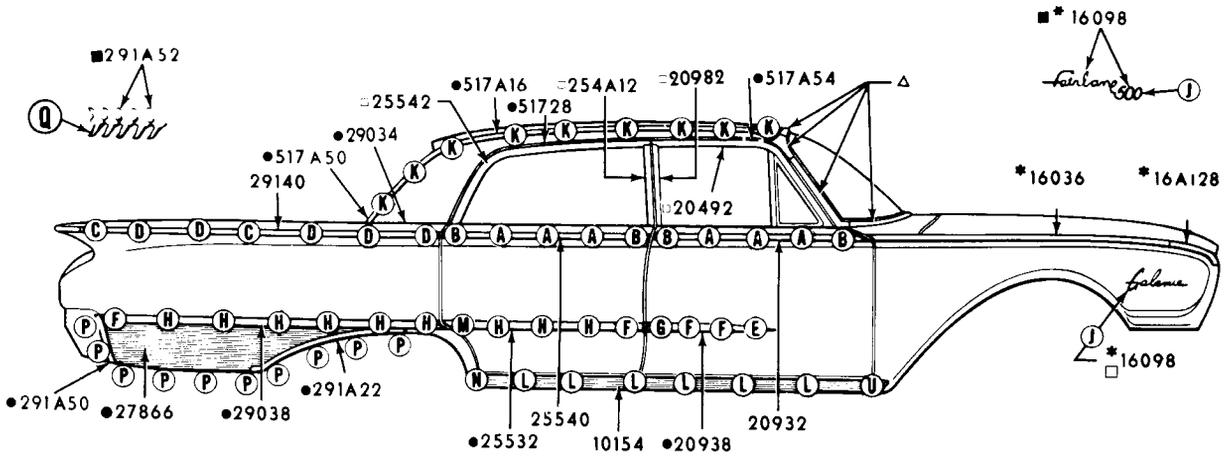

COAB16A076-K
A



COAB6420842-C
B

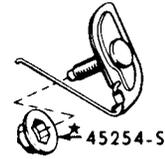

COAB6429108-E
C



COAB6429108-B
D



B9A5829120-B
E



COAZ6421094-C
F



COAB6421066-A
G



COAB6429120-A
H



373528-S (MM-227)
J



COAB6250024-A
K

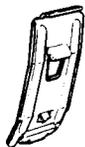

COAB6410182-A
L



COAB5825553-A
M

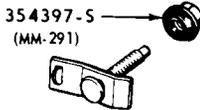

372719-S (BB-643)
N



376378-S (UU-97)
P



373503-S (MM-285-A)
Q



* 45254-S
S



52368-S(U-295)
U

* REFER TO GROUP IN CHASSIS SECTION

△ REFER TO BODY ILLUSTRATION SECTION 030

⊕ REFER TO BODY ILLUSTRATION SECTION 400

⊕ REFER TO BODY ILLUSTRATION SECTION 430

■ BODY TYPE 58A

● BODY TYPE 54 AND 75

□ BODY TYPE 54 AND 58

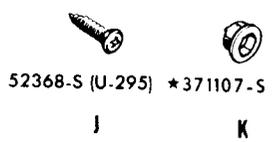
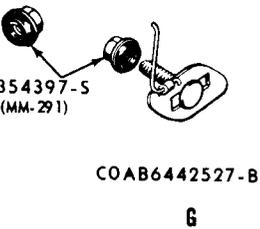
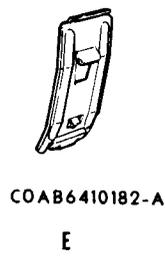
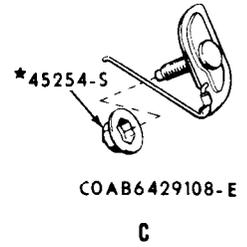
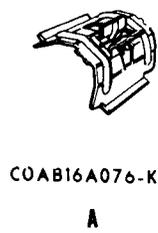
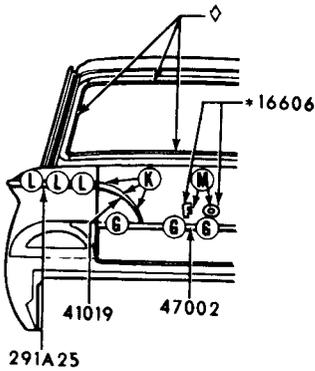
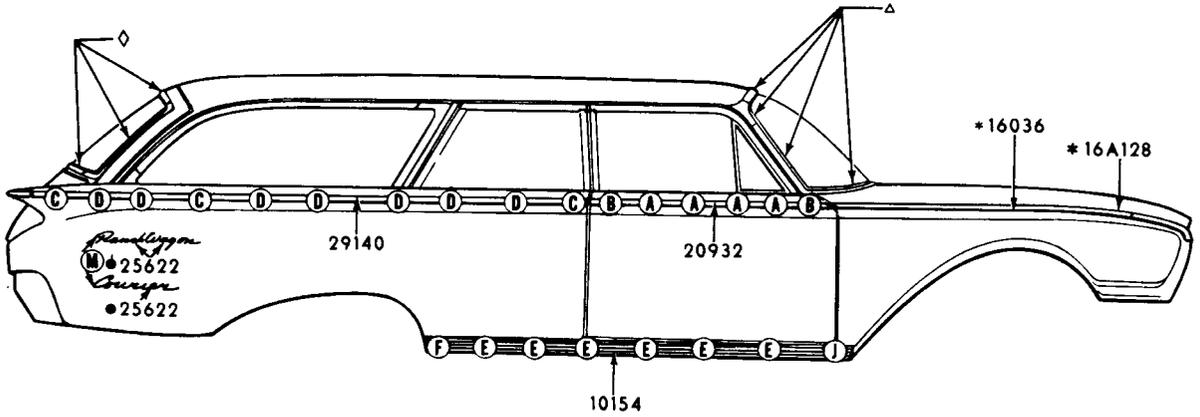

△ REFER TO BODY ILLUSTRATION SECTION 030
 ◇ REFER TO BODY ILLUSTRATION SECTION 400
 * REFER TO GROUP IN CHASSIS SECTION
 ● BODY TYPE 59C
 ● BODY TYPE 59E

**A EXTERIOR Moulding
ILLUSTRATION SECTION**

FORD CAR PARTS

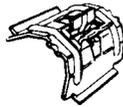
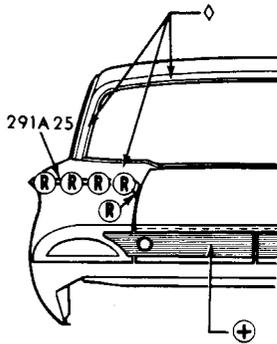
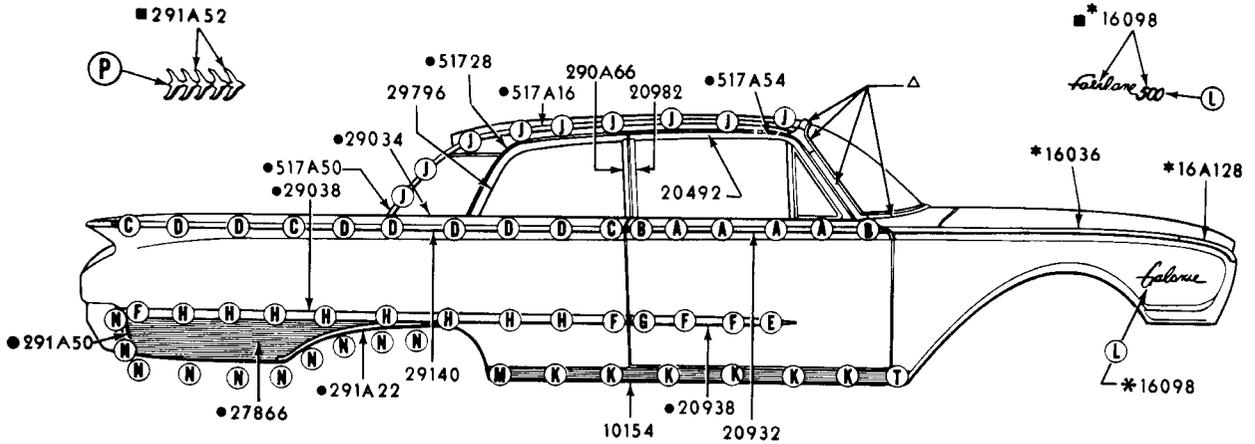

COAB16A076-K
A



COAB6420842-C
B



COAB6429108-E
C



COAB6429108-B
D

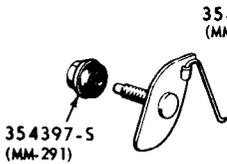

354397-S (MM-291)
354397-S (MM-291)
B9A5829120-B
E

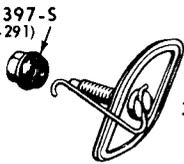

COAZ6421094-C
F



COAB6421066-A
G



COAB6429120-A
H



COAB6250024-A
J

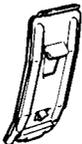

COAB6410182-A
K



373528-S (MM-227)
L



372719-S (BB-643)
M



376378-S (UU-97)
N



373503-S (MM-285-A)
P



*45254-S
R



52368-S (U-295)
T

* REFER TO GROUP IN CHASSIS SECTION

△ REFER TO BODY ILLUSTRATION SECTION 030

◇ REFER TO BODY ILLUSTRATION SECTION 400

⊕ REFER TO BODY ILLUSTRATION SECTION 430

● BODY TYPE 62A

■ BODY TYPE 64A

P-3045

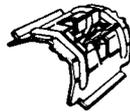
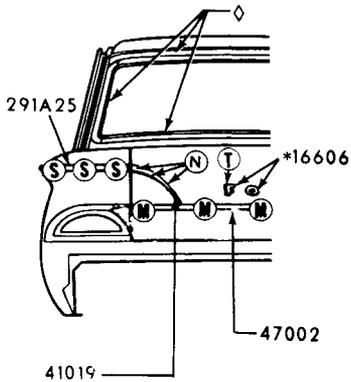
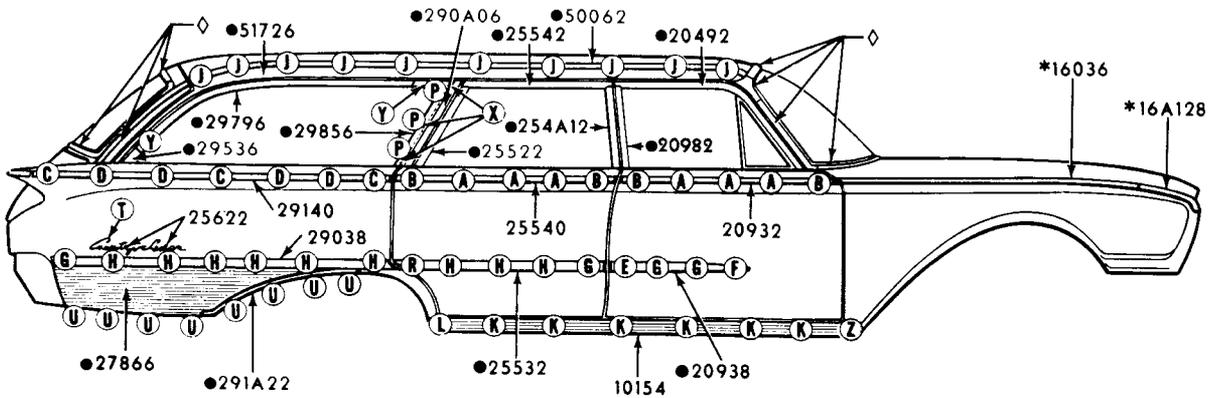

COAB16A076-K
A



COAB6420842-C
B

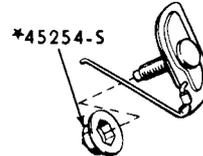

COAB6429108-E
C



COAB6429108-B
D

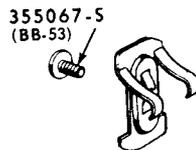

COAB6421066-A
E

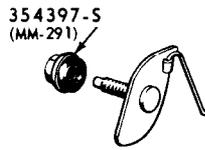

B9A5829120-B
F

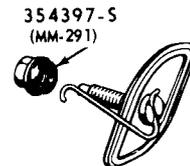

COAZ6421094-C
G



COAB6429120-A
H

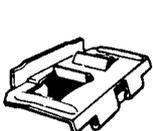

COAB6350024-B
J



COAB6410182-A
K

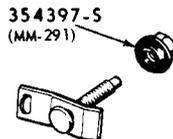

372719-S (BB-643)
L



COAB6442527-B
M



USE 373504-S (MM-285-B)
N

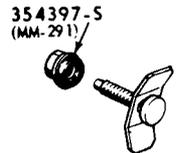

★ COMB6328507-A
P



COAB5825553-A
R



★45254-S
S



373528-S (MM-227)
T



376378-S (UU-97)
U



52720-S (U-380)
X



52005-S (U-196)
Y



52368-S(U-295)
Z



370713-S (MM-292)
AA

△ REFER TO BODY ILLUSTRATION SECTION 030
◇ REFER TO BODY ILLUSTRATION SECTION 400
* REFER TO GROUP IN CHASSIS SECTION
● BODY TYPE 71E, F

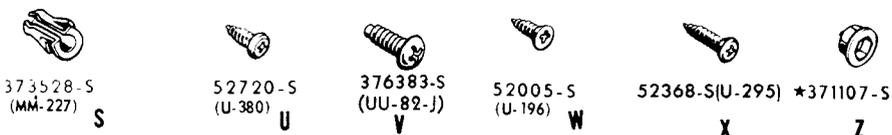
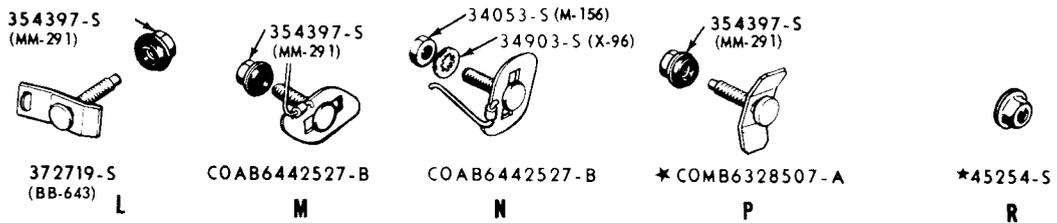
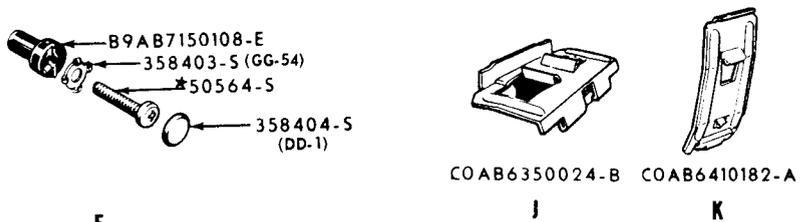
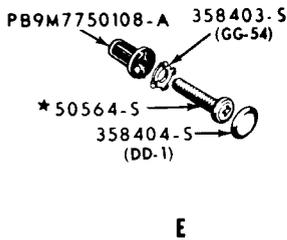
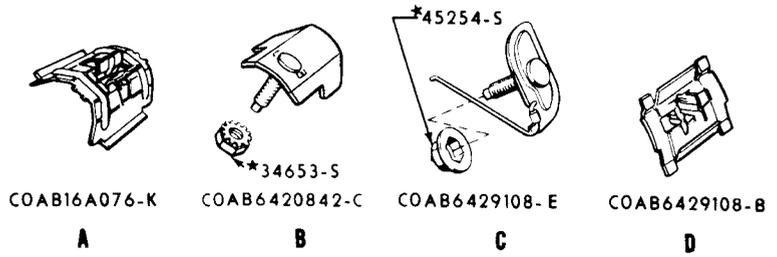
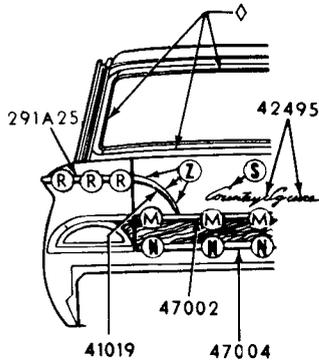
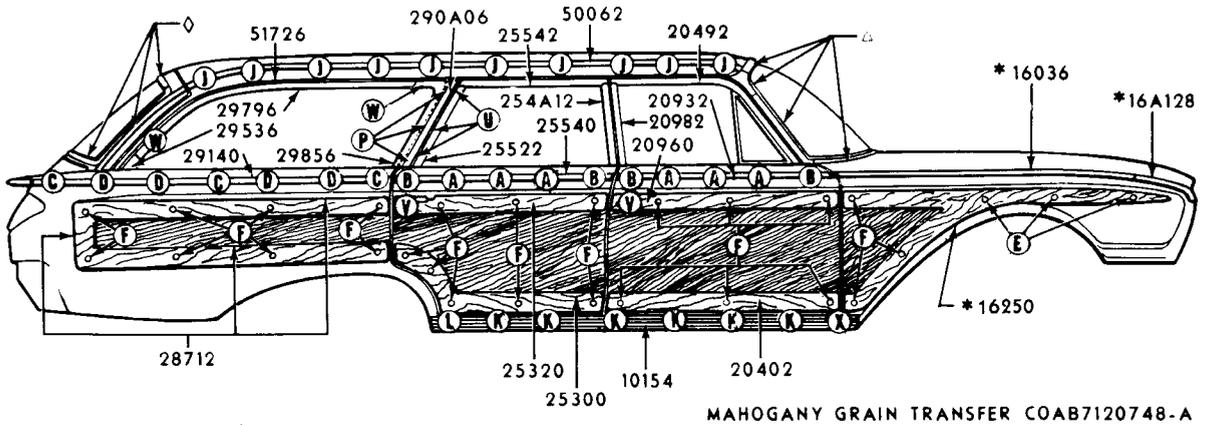

* REFER TO GROUP IN CHASSIS SECTION

△ REFER TO BODY ILLUSTRATION SECTION 030

◇ REFER TO BODY ILLUSTRATION SECTION 400

P-3052

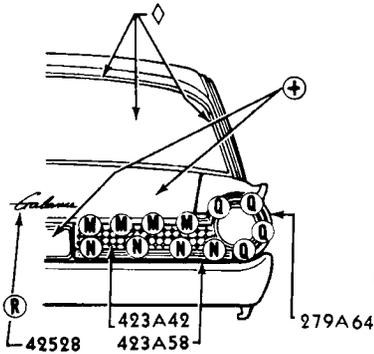
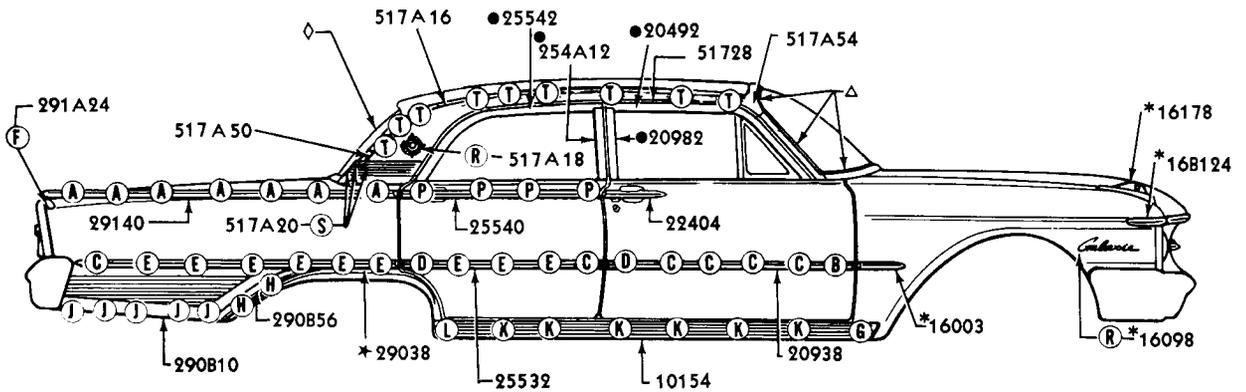

C1AB-6229144-A

A

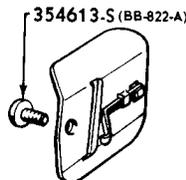

C1AB-5420884-A

B

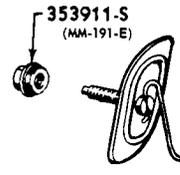

C1AB-6221094-A

C

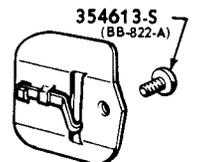

C1AB-5420880-B

D



C1AB-62290882-B

E

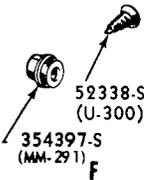

354397-S (MM-291)

F

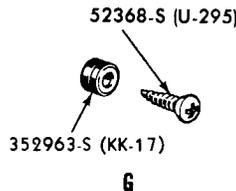

352963-S (KK-17)

G

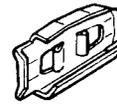

C1AB-62290878-B

H



376378-S (UU-97)

J



COAB-6410182-A

K

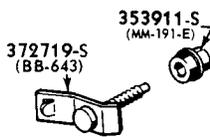

372719-S (BB-643)

L

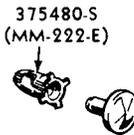

375480-S (MM-222-E)

M

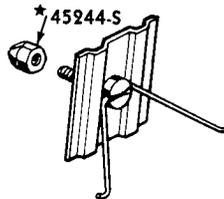

*45244-S

C1AB-6240368-A

N

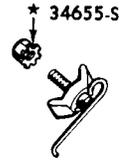

*34655-S

C1AB-5425034-A

P



371068-S (MM-171)

Q



353577-S (MM-222)

R



370548-S (MM-295)

S



*C1AB-6250024-A

T

◇ REFER TO BODY ILLUSTRATION SECTION 400

⊕ REFER TO BODY ILLUSTRATION SECTION 430

● BODY TYPE 54

* REFER TO GROUP IN CHASSIS SECTION
△ REFER TO BODY ILLUSTRATION SECTION 030

P-3321

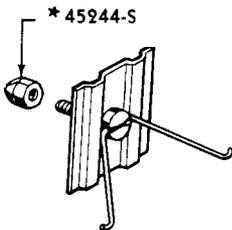
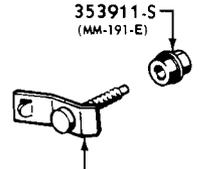
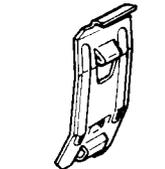
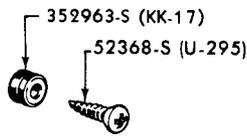
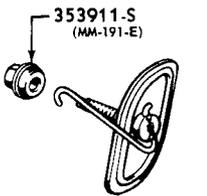
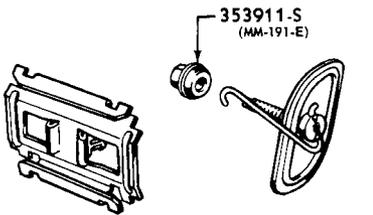
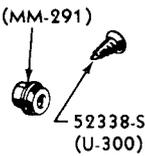
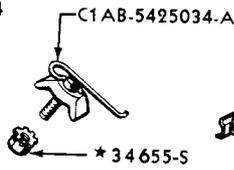
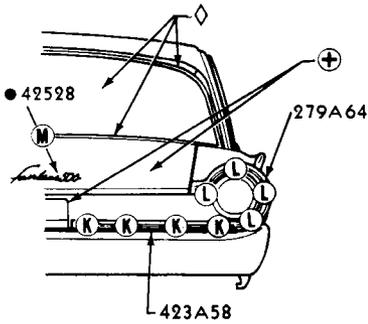
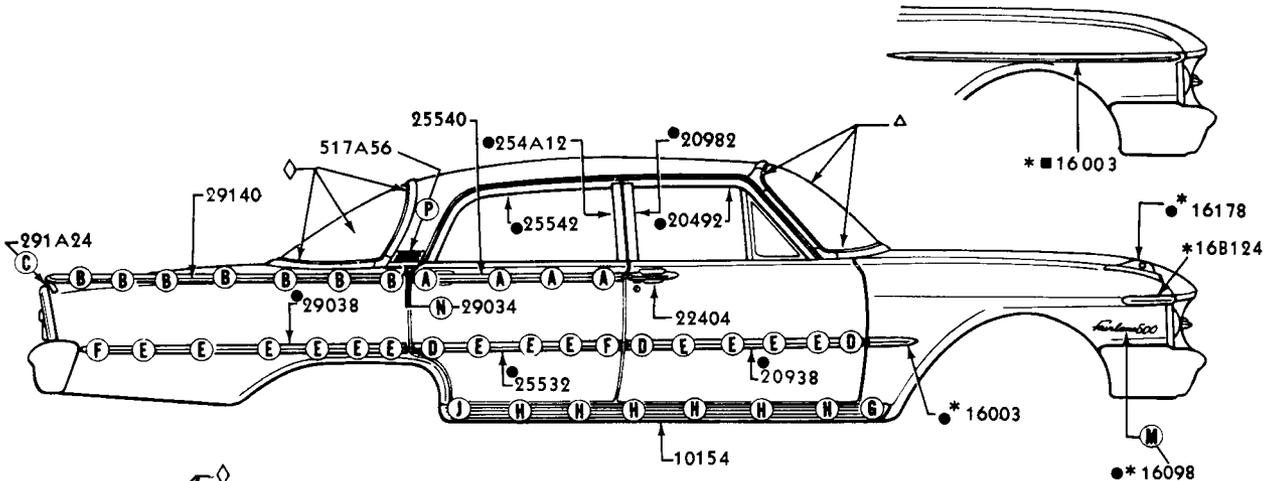

C1AB-6240368-A

371068-S (MM-171)

353577-S (MM-222)

52720-S (U-380)

353911-S (MM-191-E)

* REFER TO GROUP IN CHASSIS SECTION
 △ REFER TO BODY ILLUSTRATION SECTION 030
 ■ BODY TYPE 58E, F

◇ REFER TO BODY ILLUSTRATION SECTION 400
 ⊕ REFER TO BODY ILLUSTRATION SECTION 430
 ● BODY TYPE 58A

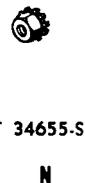
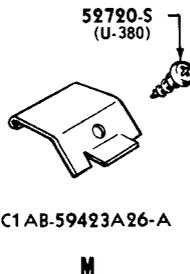
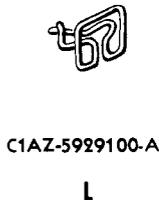
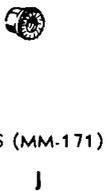
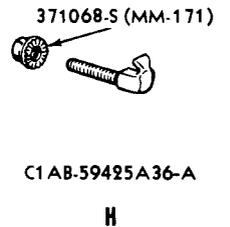
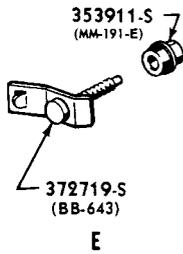
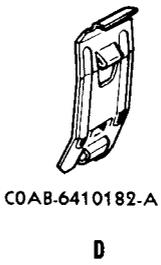
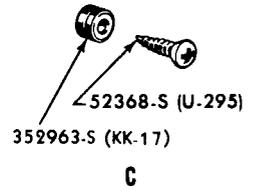
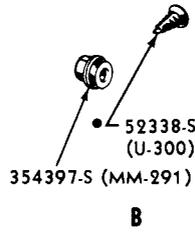
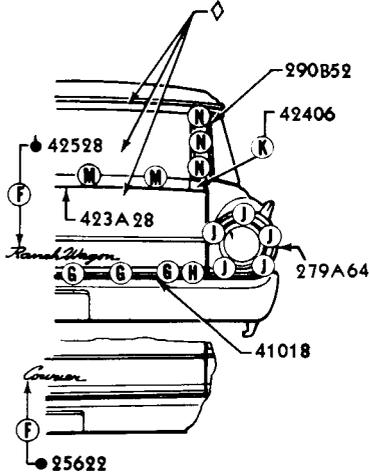
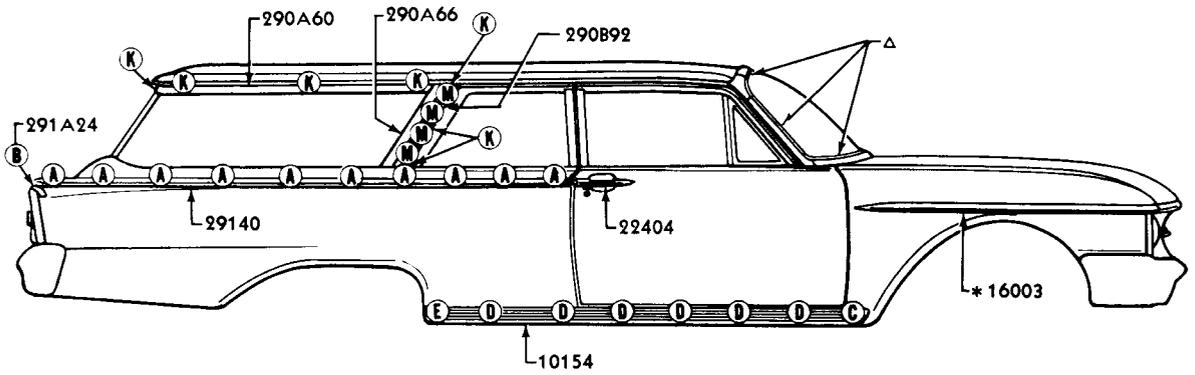

* REFER TO GROUP IN CHASSIS SECTION
△ REFER TO BODY ILLUSTRATION SECTION 030
◆ BODY TYPE 59C

● BODY TYPE 59E
◇ REFER TO BODY ILLUSTRATION SECTION 400

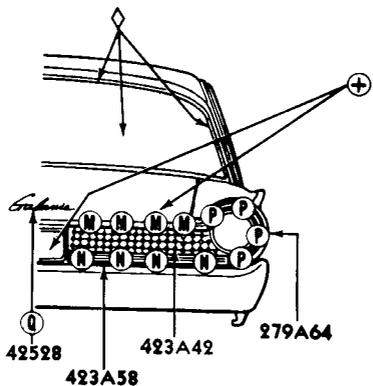
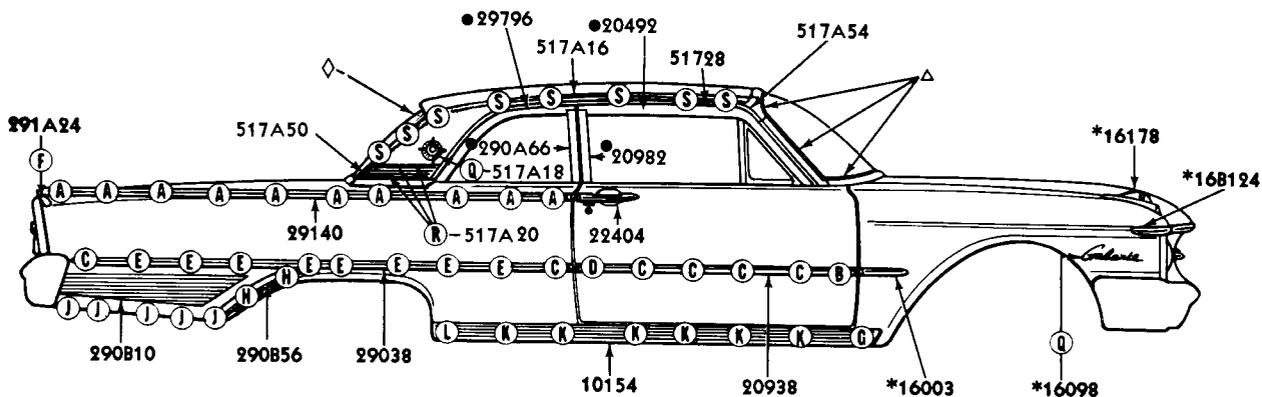

C1AB-6229144-A
A

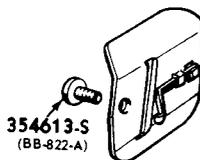

C1AB-5420884-A
B



C1AB-6221094-A
C

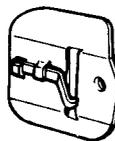

C1AB-5420880-B
D



C1AB-62290882-B
E



F



G

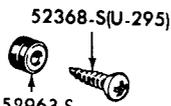

C1AB-62290878-B
H



376378-S (UU-97)
J



COAB-6410182-A
K

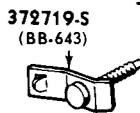

L



C1AB-62423A64-A
M



C1AB-6240368-A
N



371068-S (MM-171)
P



353577-S (MM-222)
Q



370548-S (MM-295)
R



COAB-6 2500 24 -A
S

* REFER TO GROUP IN CHASSIS SECTION
△ REFER TO BODY ILLUSTRATION SECTION 030

◇ REFER TO BODY ILLUSTRATION SECTION 400
⊕ REFER TO BODY ILLUSTRATION SECTION 430

● BODY TYPE 62

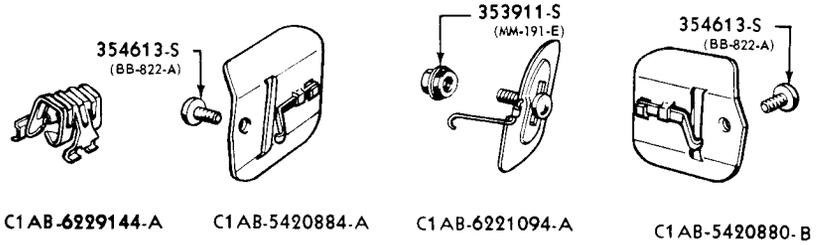
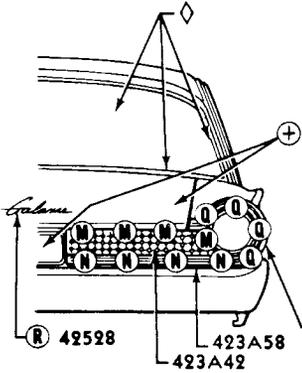
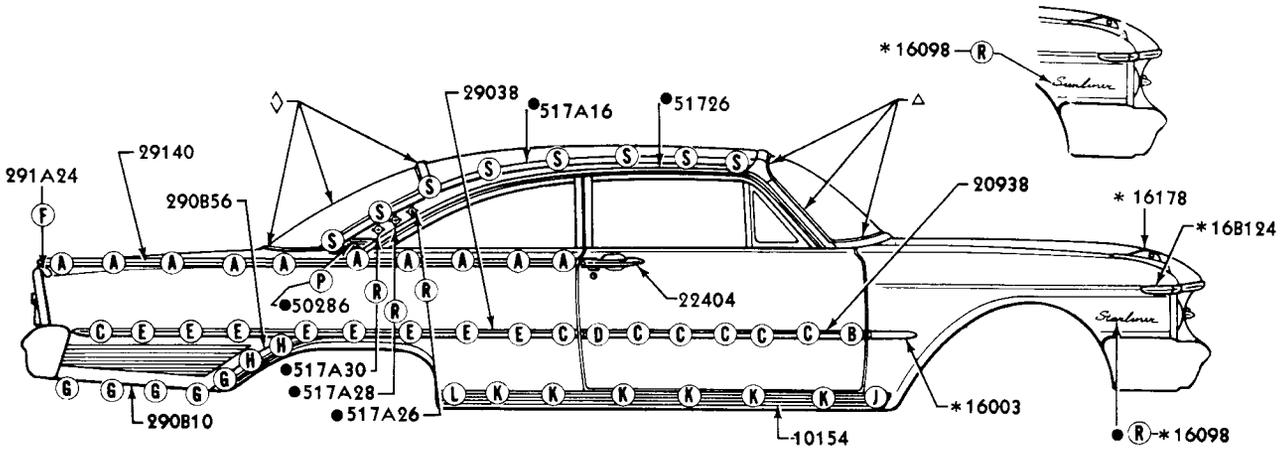

C1AB-6229144-A C1AB-5420884-A C1AB-6221094-A C1AB-5420880-B

A

B

C

D



C1AB-62290882-B

E

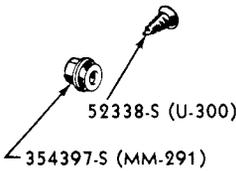

F



G

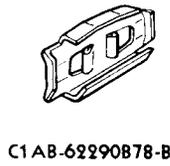

C1AB-62290878-B

H

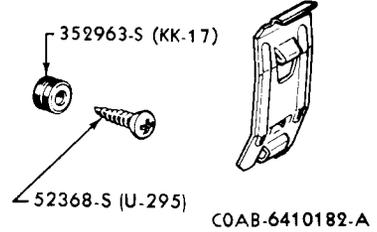

J

COAB-6410182-A

K

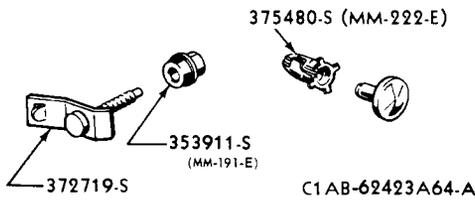

L

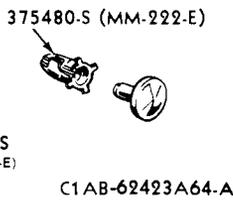

M

C1AB-62423A64-A

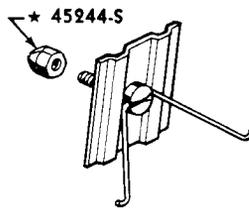

C1AB-6240368-A

N

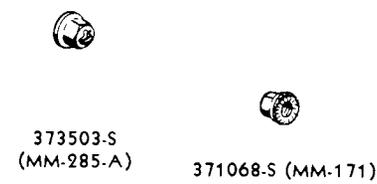

P

Q



353577-S (MM-222)

R

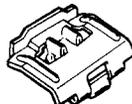

COAB-6350024-B

S

- * REFER TO GROUP IN CHASSIS SECTION
- △ REFER TO BODY ILLUSTRATION SECTION 030
- ◇ REFER TO BODY ILLUSTRATION SECTION 400
- ⊕ REFER TO BODY ILLUSTRATION SECTION 430

- BODY TYPE 63
- BODY TYPE 76

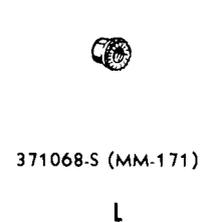
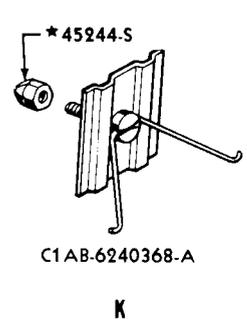
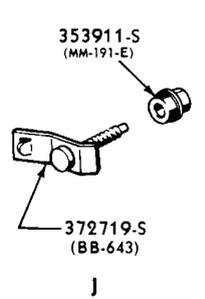
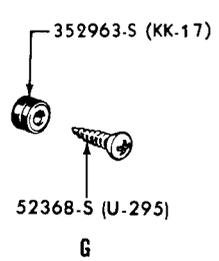
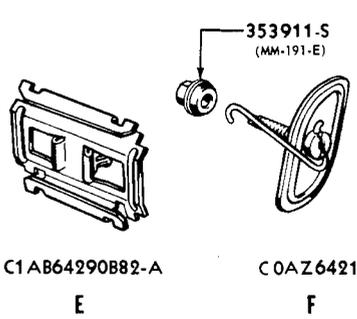
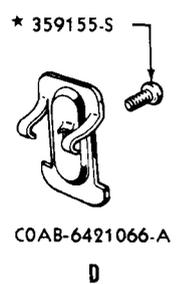
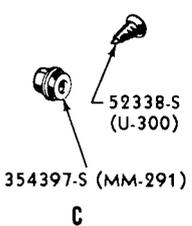
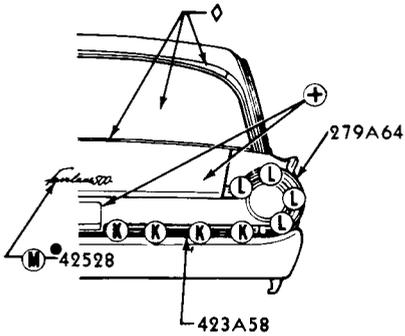
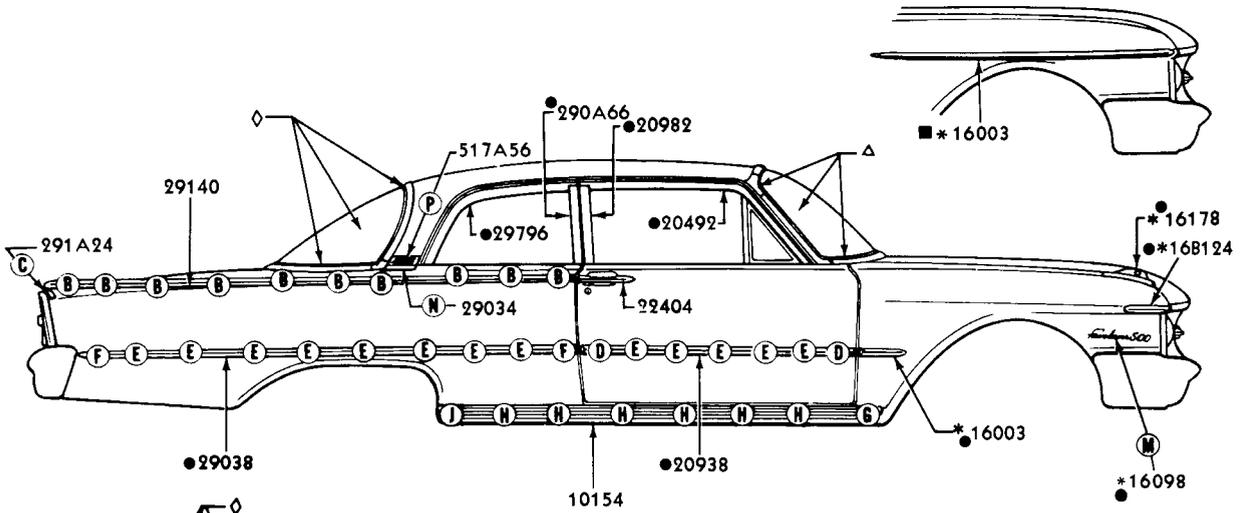

* REFER TO GROUP IN CHASSIS SECTION
 Δ REFER TO BODY ILLUSTRATION SECTION 030
 ■ BODY TYPE 64F, H

◇ REFER TO BODY ILLUSTRATION SECTION 400
 ⊕ REFER TO BODY ILLUSTRATION SECTION 430
 ● BODY TYPE 64A

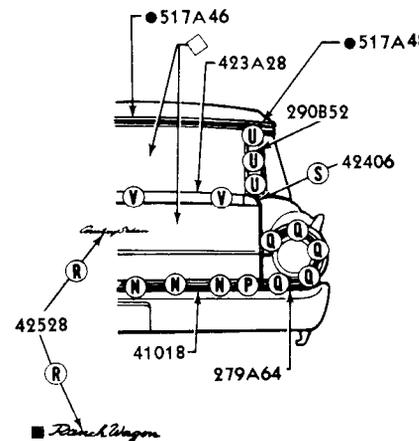
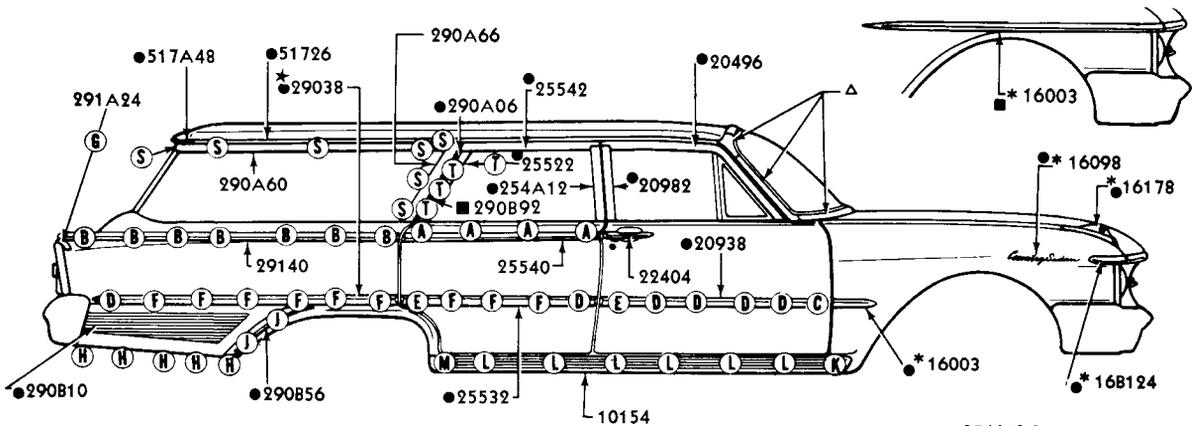

- * 34655-S C1AB-5425034-A **A**
- C1AB-6229144-A **B**
- 354613-S (BB-822-A) C1AB-5420884-A **C**
- 353911-S (MM-191-E) C1AB-6221094-A **D**
- 354613-S (BB-822-A) C1AB-5420880-B **E**
- C1AB-62290882-B **F**
- 52338-S (U-300) **G**
- 376378-S (UU-97) **H**
- C1AB-62290878-B **J**
- * 357165-S 352963-S (KK-17) **K**
- COAB-6410182-A **L**
- 353911-S (MM-191-E) 372719-S (BB-643) **M**
- *C1AB-59407A12-B **N**
- 371068-S (MM-171) C1AB-59425A36-A **P**
- 371068-S (MM-171) **Q**
- 353577-S (MM-222) **R**
- 52720-S (U-380) **S**
- C1AZ-5929100-A **T**
- * 34655-S **U**
- * C1AB59423A26-A 52720-S (U-380) **V**

◇ REFER TO BODY ILLUSTRATION SECTION 400
 * REFER TO GROUP IN CHASSIS SECTION
 △ REFER TO BODY ILLUSTRATION SECTION 030
 ● BODY TYPE 71E, F
 ■ BODY TYPE 71H

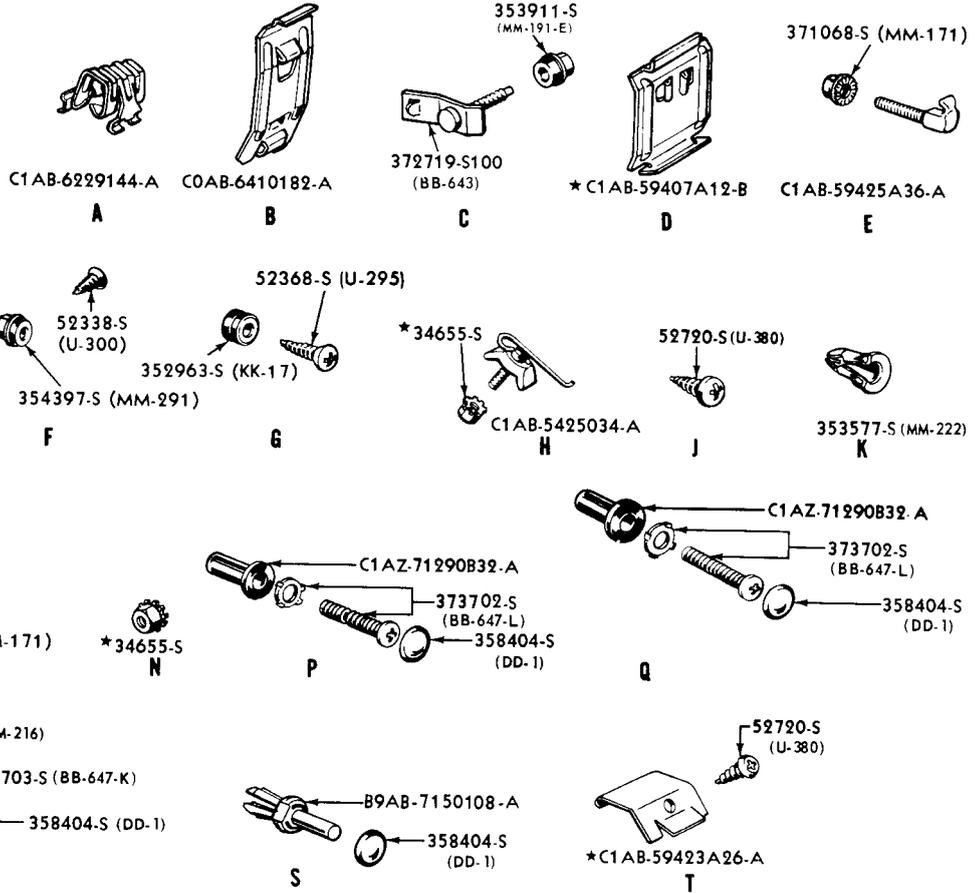
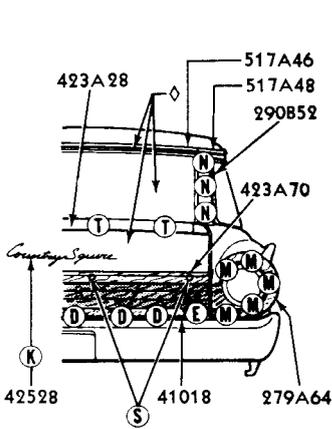
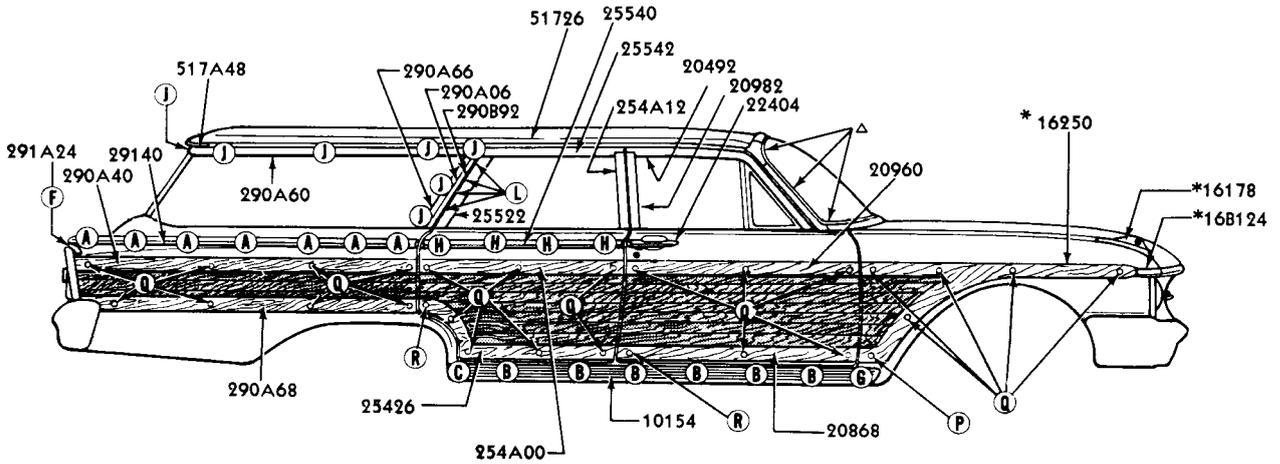

* REFER TO GROUP IN CHASSIS SECTION
 Δ REFER TO BODY ILLUSTRATION SECTION 030
 ◇ REFER TO BODY ILLUSTRATION SECTION 400

MAHOGANY GRAIN TRANSFER (BODY SIDE) C1AB-7120748-A
 MAHOGANY GRAIN TRANSFER (TAIL GATE) C1AB-7120748-B

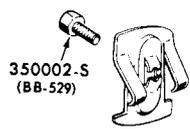
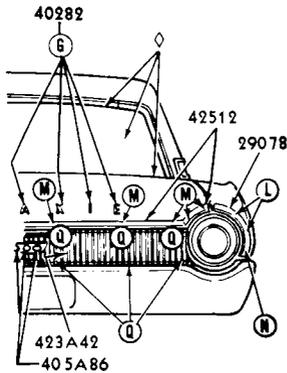
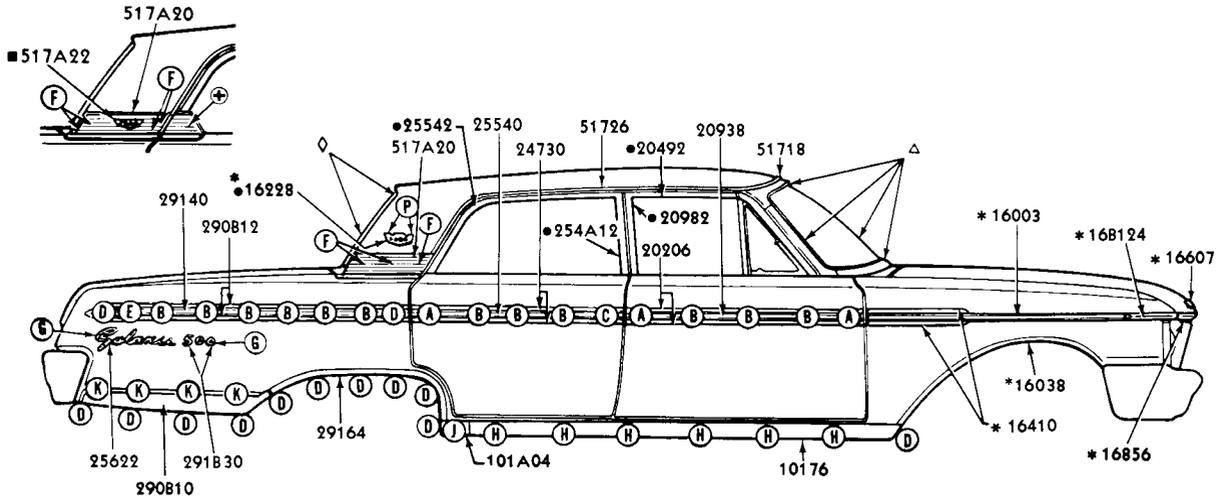

C2AZ-6221066-A
A

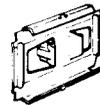

C2AZ-6229120-A
B



COAZ-6421094-C
C



376378-S (UU-97)
D



C2AZ-6229108-A
E



375526-S (MM-295-H)
F



375890-S (MM-222-A)
G



C2AZ-5410182-A
H



*356479-S
353911-S (MM-191-E)
J



52413-S (U-316)
K



C2AZ-6229185-A
L

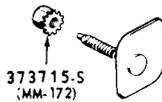

C2AZ-6242527-A
M

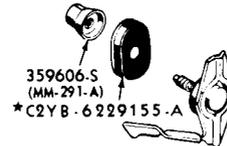

C2AZ-6242527-B
N



375480-S (MM-222-E)
P



376378-S (UU-97)
Q

*REFER TO GROUP IN CHASSIS SECTION

△ REFER TO BODY ILLUSTRATION SECTION 030

● BODY TYPE 54A

■ BODY TYPE 75

◇ REFER TO BODY ILLUSTRATION SECTION 400

⊙ REFER TO BODY ILLUSTRATION SECTION 240

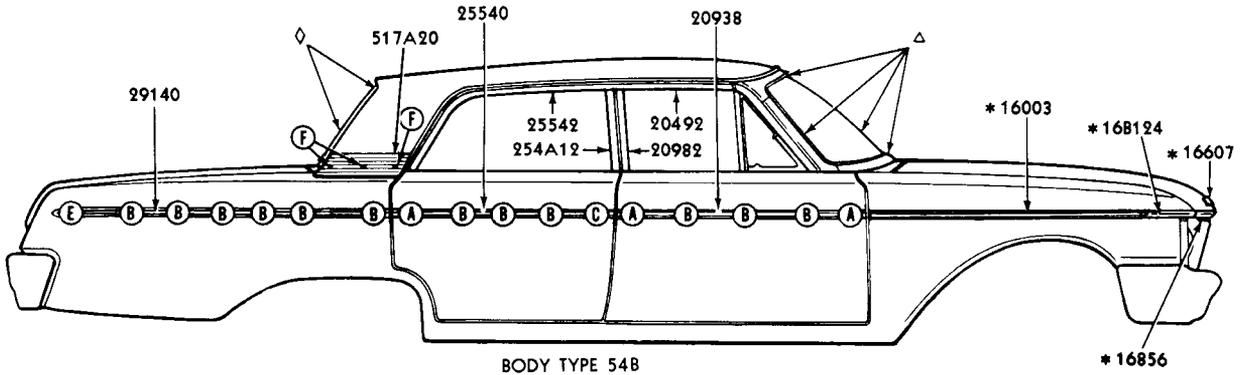

BODY TYPE 54B

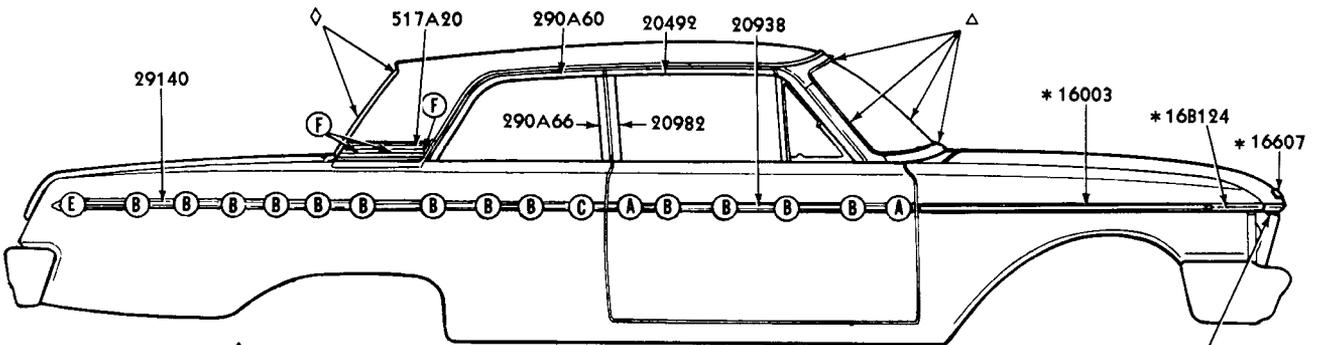

BODY TYPE 62B

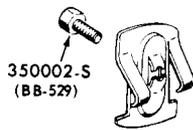
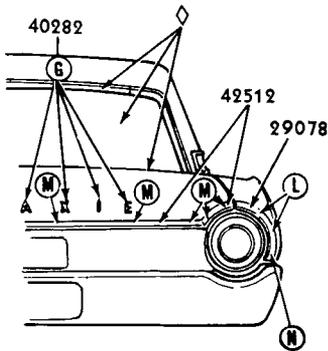

350002-S
(BB-529)

C2AZ-6221066-A
A



C2AZ-6229120-A
B

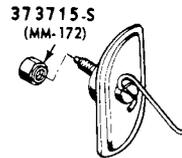

373715-S
(MM-172)

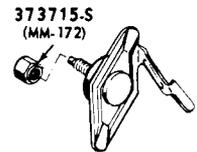

373715-S
(MM-172)

ALTERNATES

C0AZ-6241094-C
C



*359606-S
(MM-291-A)

C2AZ-6229108-A
E



375526-S
(MM-295-H)
F



375890-S
(MM-222-A)
G

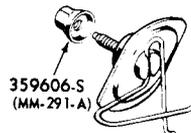

359606-S
(MM-291-A)

C2AZ-6229185-A
L

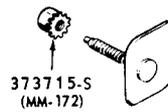

373715-S
(MM-172)



373715-S
(MM-172)

ALTERNATES

C2AZ-6242527-A
M

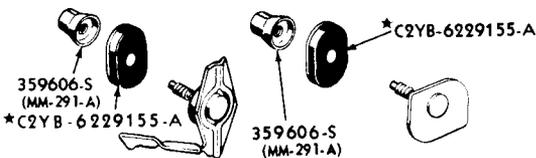

359606-S
(MM-291-A)

*C2YB-6229155-A



359606-S
(MM-291-A)



*C2YB-6229155-A

ALTERNATES

C2AZ-6242527-B
N

*REFER TO GROUP IN CHASSIS SECTION
△ REFER TO BODY ILLUSTRATION SECTION 030
◇ REFER TO BODY ILLUSTRATION SECTION 400

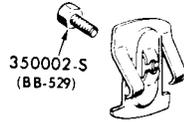
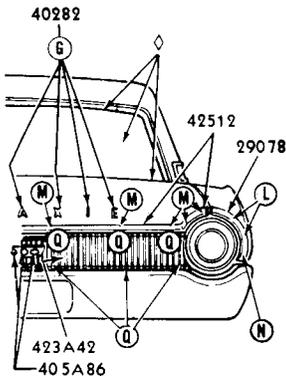
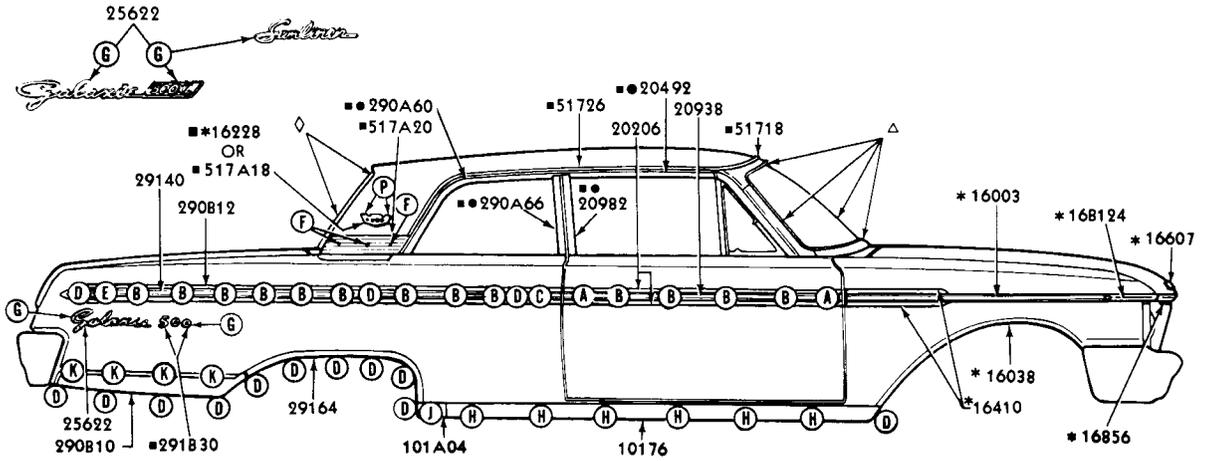

C2AZ-6221066-A
A



C2AZ-6229120-A
B

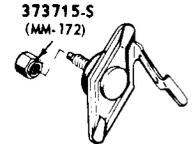
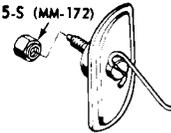

ALTERNATES

COAZ-6421094-C
C



376378-S (UU-97)
D

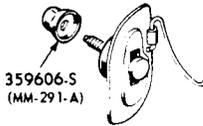

359606-S (MM-291-A)
C2AZ-6229108-A
E



375526-S (MM-295-H)
F



375890-S (MM-222-A)
G



C2AZ-5410182-A
H



353911-S (MM-191-E)
J



52413-S (U-316)
K

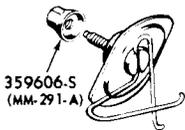

359606-S (MM-291-A)
C2AZ-6229185-A
L

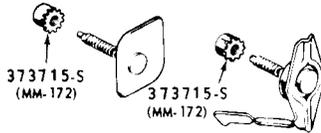

ALTERNATES

C2AZ-6242527-A
M



ALTERNATES

C2AZ-6242527-B
N



375480-S (MM-222-E)
P



376378-S (UU-97)
Q

*REFER TO GROUP IN CHASSIS SECTION
 Δ REFER TO BODY ILLUSTRATION SECTION 030
 ● BODY TYPE 62A ONLY
 ■ BODY TYPE 62A AND 65 ONLY
 ◇ REFER TO BODY ILLUSTRATION SECTION 400

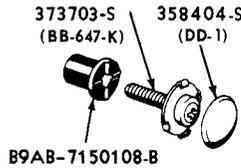
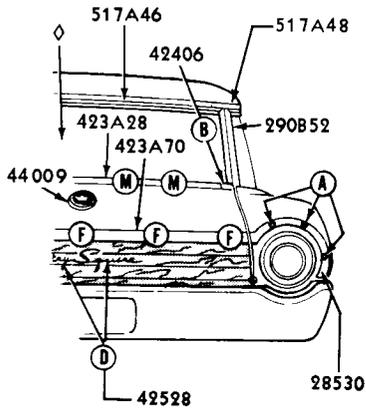
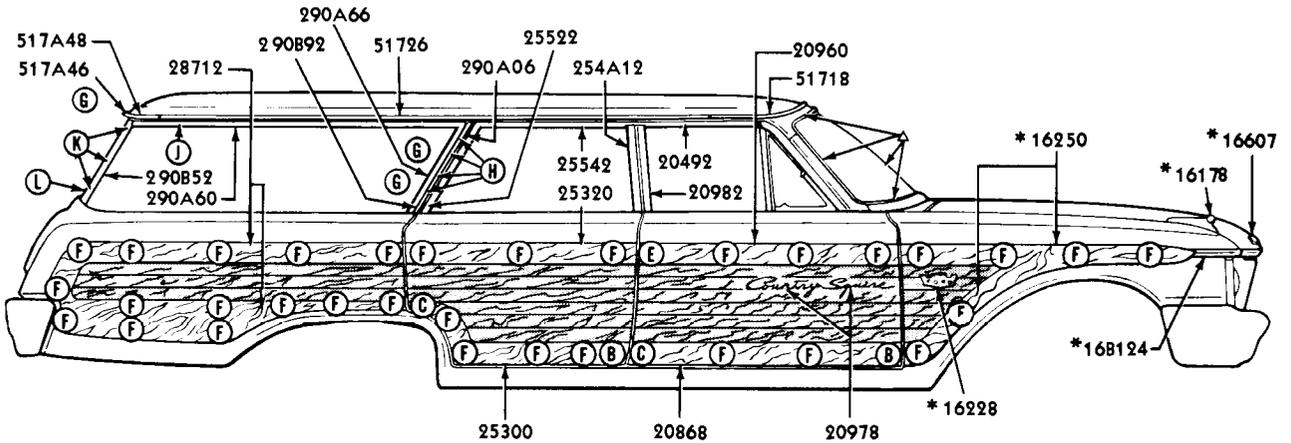

52721-S (U-382-B)

A



B

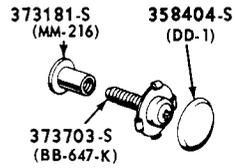

C



375890-S (MM-222-A)

D

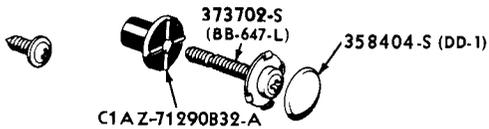

350754-S (UU-86)

E

F



376378-S (UU-97)

G



C1AZ-5929100-A

H



52720-S (U-380)

J

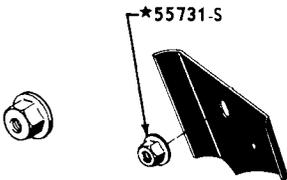

*55731-S

K

L

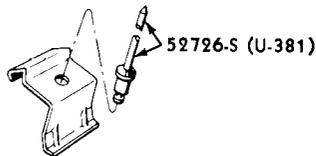

M

WALNUT GRAIN TRANSFER (BODY SIDE) C2AB7120748-A
WALNUT GRAIN TRANSFER (TAILGATE) C2AB7120748-B

△ REFER TO BODY ILLUSTRATION SECTION 030
* REFER TO GROUP IN CHASSIS SECTION

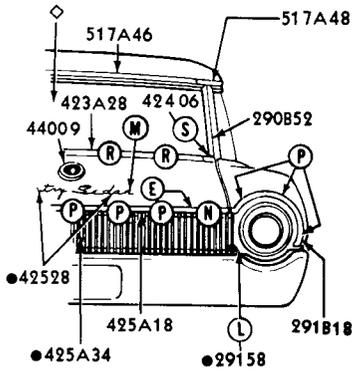
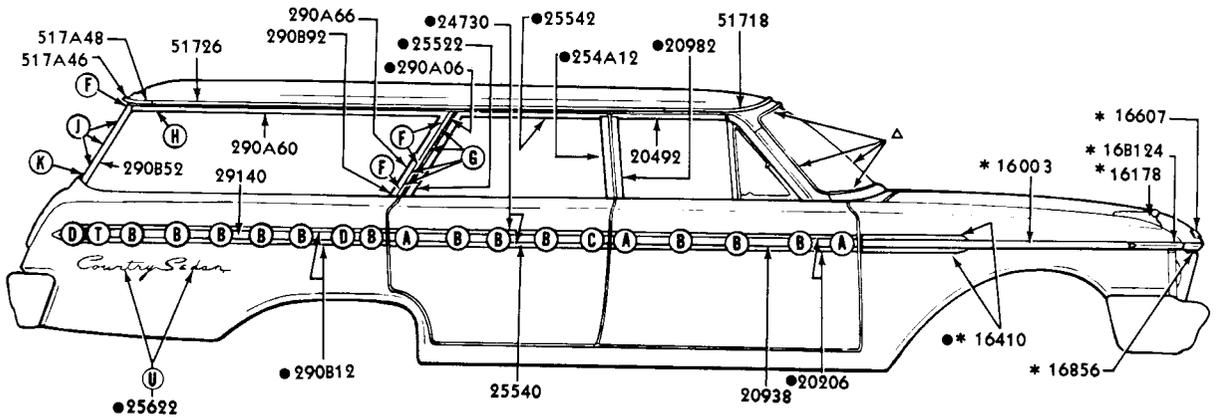

C2AZ-6221066-A
A

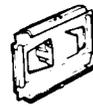

C2AZ-6229120-A
B

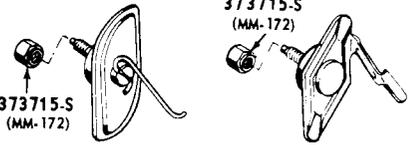

ALTERNATES
COAZ-6421094-C
C



376378-S (UU-97)
D



375557-S (UU-82)
E



376378-S (UU-97)
F



C1AZ-5929100-A
G



52720-S (U-380)
H



*55731-S
J

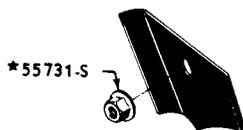

C1AB-59291B14-A
K



*376394-S
L



353577-S (MM-222)
M

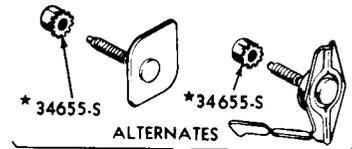

ALTERNATES
C2AZ-6242527-A
N

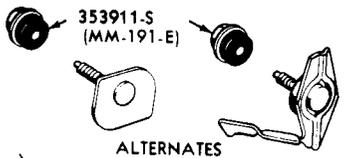

ALTERNATES
C2AZ-6242527-B
P



*C2AZ-71423A26-A
R

USE 52726-S (U-381) FOR SERVICE



*52718-S
S

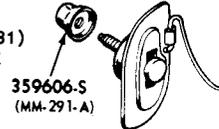

C2AZ-6229108-A
T



375890-S (MM-222-A)
U

* REFER TO CHASSIS ILLUSTRATION SECTION 160
 Δ REFER TO BODY ILLUSTRATION SECTION 030
 ◇ REFER TO BODY ILLUSTRATION SECTION 400
 ● BODY TYPE 71B, C ONLY

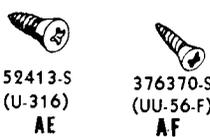
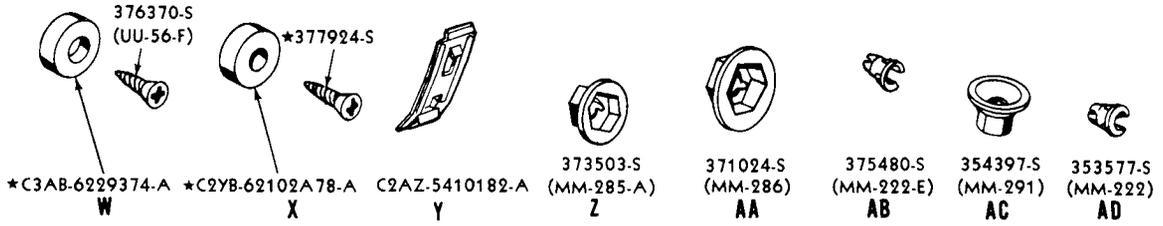
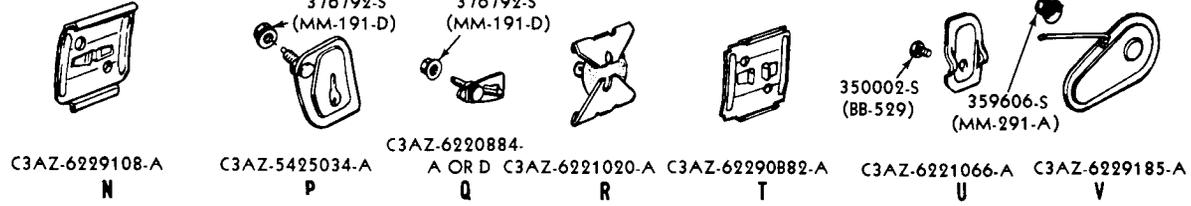
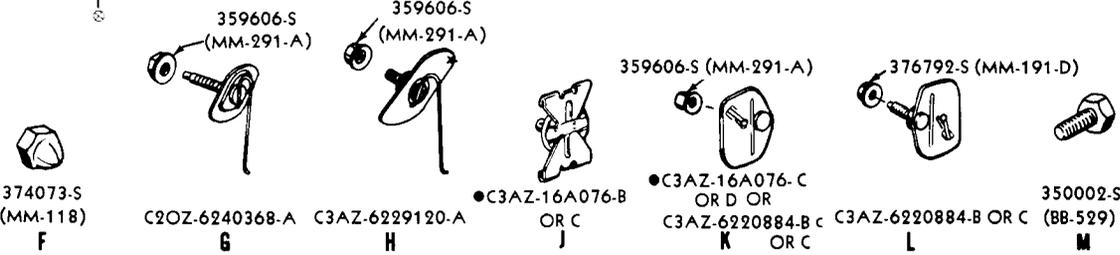
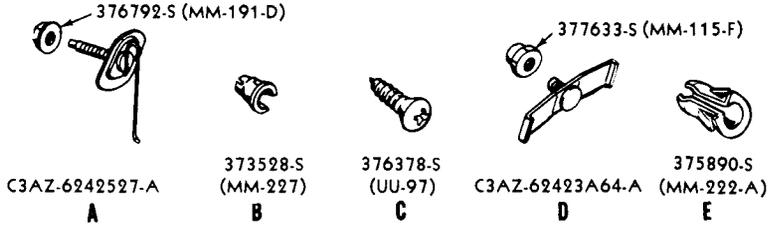
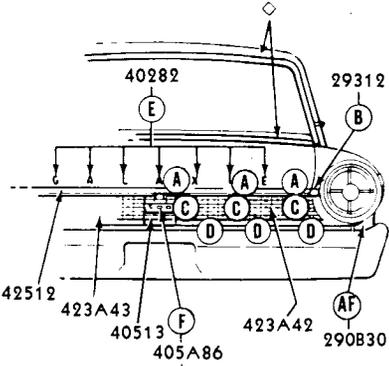
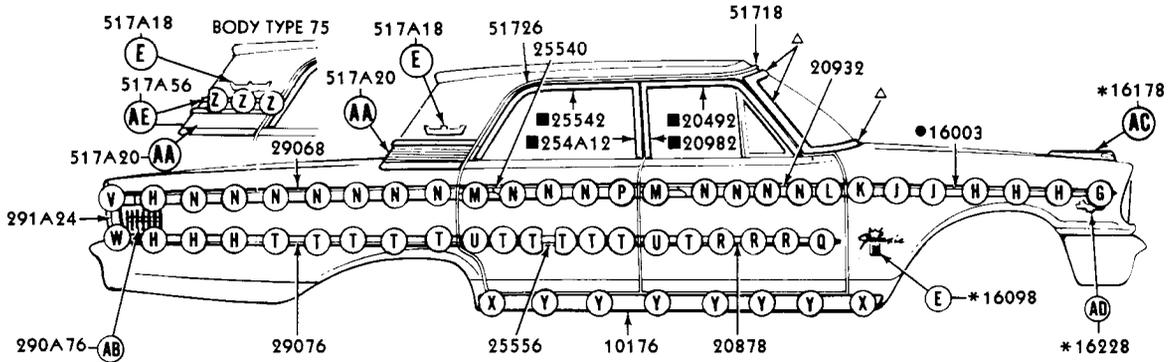

△ REFER TO BODY ILLUSTRATION SECTION 030 ■ BODY TYPE 54A
◇ REFER TO BODY ILLUSTRATION SECTION 400 ⊕ ALSO REFER TO BODY ILLUSTRATION SECTION 430
*REFER TO GROUP IN CHASSIS SECTION P-3950

**A EXTERIOR MOULDING
ILLUSTRATION SECTION**

FORD CAR PARTS

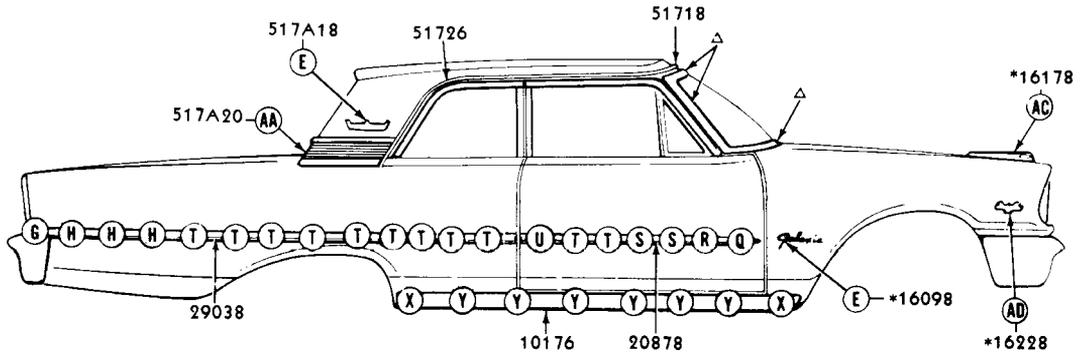

BODY TYPE 62B

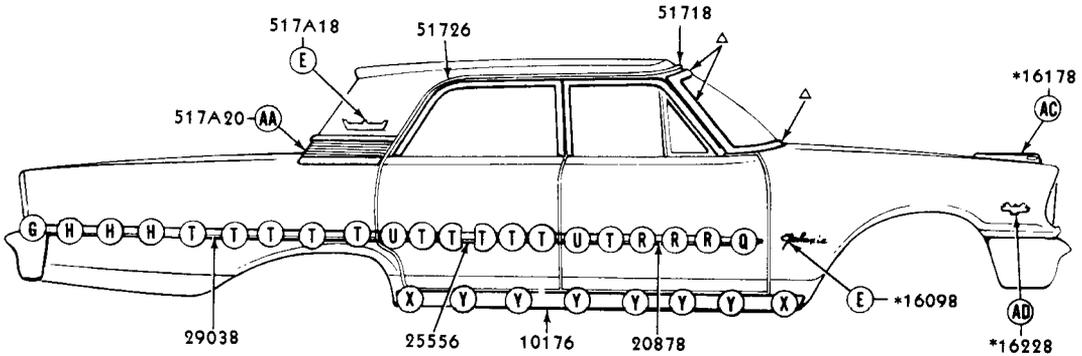

BODY TYPE 54B

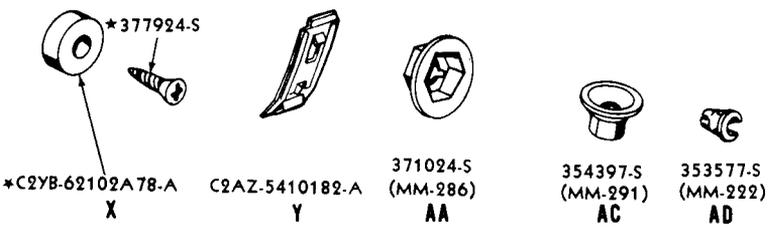
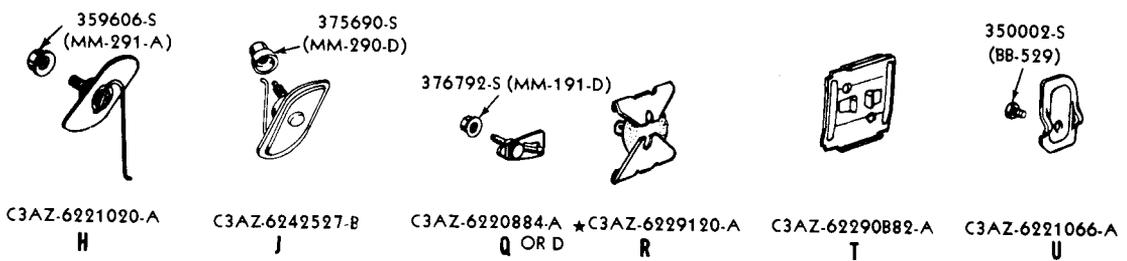
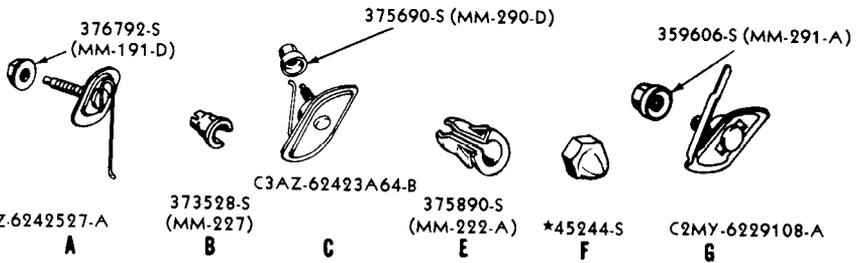
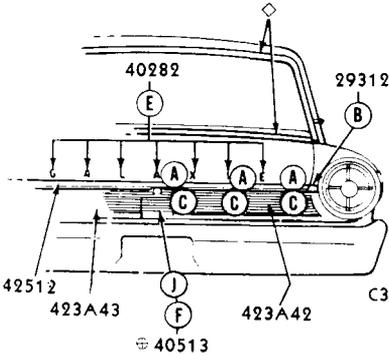

▲ REFER TO BODY ILLUSTRATION SECTION 030
 ◇ REFER TO BODY ILLUSTRATION SECTION 400
 * REFER TO GROUP IN CHASSIS SECTION
 ⊕ ALSO REFER TO BODY ILLUSTRATION SECTION 430

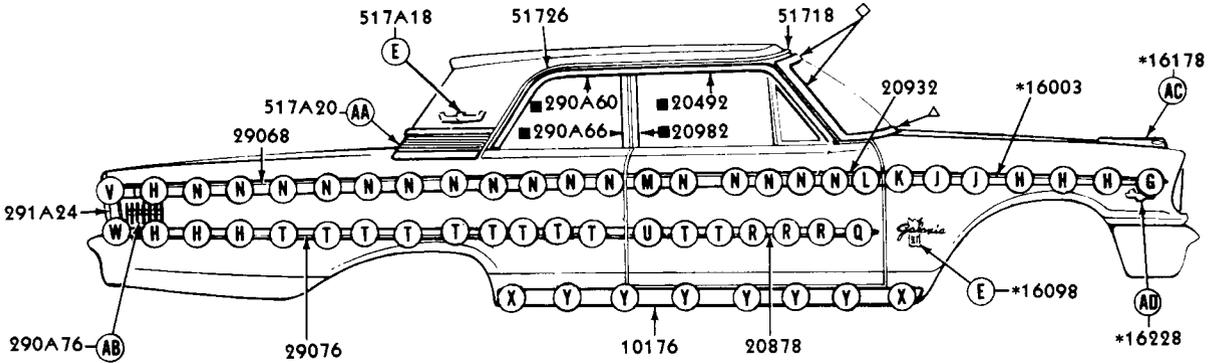

376792-S (MM-191-D)

A

377633-S (MM-115-F)

D

373528-S (MM-227)

B

376378-S (UU-97)

C

375890-S (MM-222-A)

E

359606-S (MM-291-A)

G

359606-S (MM-291-A)

H

359606-S (MM-291-A)

K

374073-S (MM-118)

F

C2OZ-6240368-A

G

*C3AZ-16A076-B OR C3AZ-6220884-B OR C

J

376792-S (MM-191-D)

L

350002-S (BB-529)

M

ALTERNATES

C3AZ-6229108-A

N

376792-S (MM-191-D)

Q OR D

ALTERNATES

C3AZ-6221020-A

R

ALTERNATES

C3AZ-62290882-A

T

350002-S (BB-529)

U

359606-S (MM-291-A)

V

376370-S (UU-56-F)

W

*377924-S

X

371024-S (MM-286)

AA

375480-S (MM-222-E)

AB

354397-S (MM-291)

AC

353577-S (MM-222)

AD

376370-S (UU-56-F)

AF

354397-S (MM-191)

AG

52413-S (U-316)

AH

BODY TYPE 62A
 *REFER TO GROUP IN CHASSIS SECTION
 ▲REFER TO SOFT TRIM SECTION
 △REFER TO BODY ILLUSTRATION SECTION 030
 ◇REFER TO BODY ILLUSTRATION SECTION 400
 ⊕ALSO REFER TO BODY ILLUSTRATION SECTION 430

A EXTERIOR MOULDING ILLUSTRATION SECTION

FORD CAR PARTS

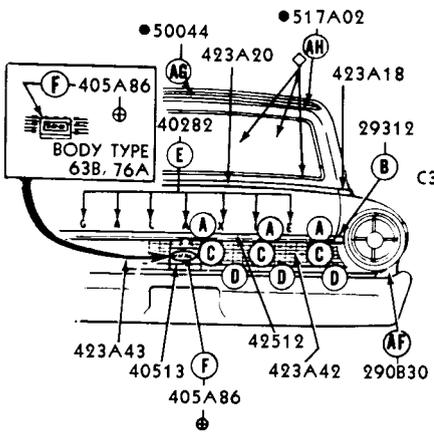
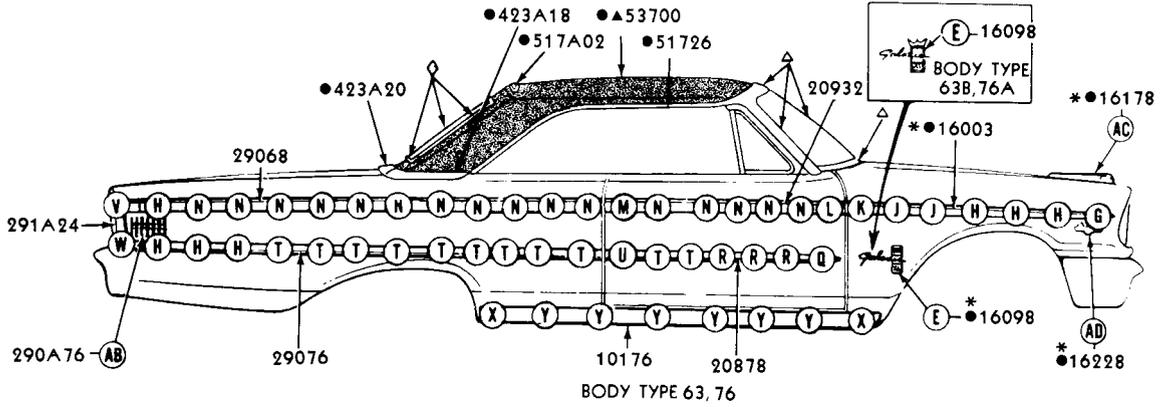

- 376792-S (MM-191-D) **A**
- 373528-S (MM-227) **B**
- 376378-S (UU-97) **C**
- 377633-S (MM-115-F) **D**
- 375890-S (MM-222-A) **E**
- 359606-S (MM-291-A) **F**
- 359606-S (MM-291-A) **G**
- 359606-S (MM-291-A) **H**
- 359606-S (MM-291-A) **J**
- 359606-S (MM-291-A) **K**
- 374073-S (MM-118) **F**
- C2OZ-6240368-A **G**
- C3AZ-6229120-A *C3AZ-16A076-B **H**
- C3AZ-6220884-B OR C **K**
- 376792-S (MM-191-D) **L**
- 350002-S (BB-529) **M**
- 376792-S (MM-191-D) **N**
- 376792-S (MM-191-D) **Q**
- 376792-S (MM-191-D) **R**
- 376792-S (MM-191-D) **T**
- 350002-S (BB-529) **U**
- 359606-S (MM-291-A) **V**
- 376370-S (UU-56-F) **W**
- *377924-S **X**
- 375480-S (MM-222-E) **AB**
- 354397-S (MM-291) **AC**
- 353577-S (MM-222) **AD**

ALTERNATES
 C3AZ-6229108-A C3AZ-6220884-A OR D C3AZ-6221020-A C3AZ-62290882-A

ALTERNATES
 C3AZ-6229108-A C3AZ-6220884-A OR D C3AZ-6221020-A C3AZ-62290882-A

- 376370-S (UU-56-F) **AF**
- 354397-S (MM-191) **AG**
- C2OZ-6242527-A **AG**
- 52413-S (U-316) **AH**

*REFER TO GROUP IN CHASSIS SECTION
 ▲REFER TO SOFT TRIM SECTION
 △REFER TO BODY ILLUSTRATION SECTION 030
 ◇REFER TO BODY ILLUSTRATION SECTION 400
 ⊕ALSO REFER TO BODY ILLUSTRATION SECTION 430

●BODY TYPE 63

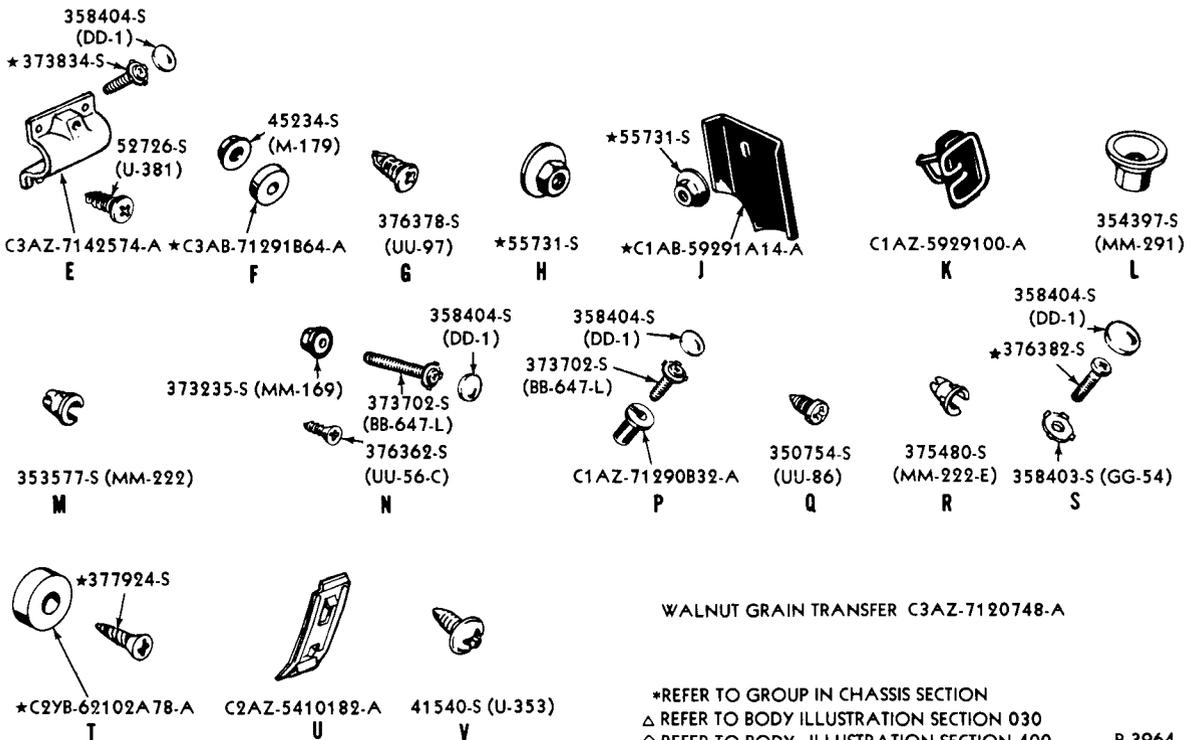
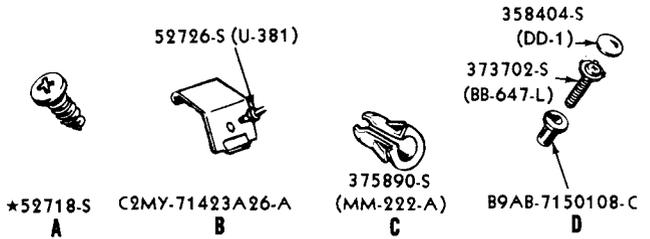
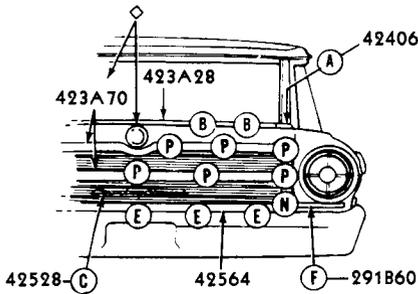
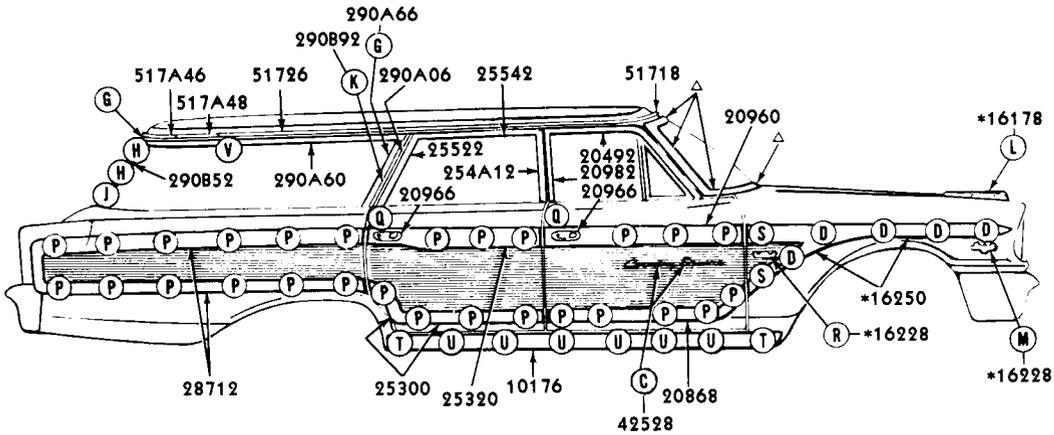

WALNUT GRAIN TRANSFER C3AZ-7120748-A

*REFER TO GROUP IN CHASSIS SECTION
 Δ REFER TO BODY ILLUSTRATION SECTION 030
 ◇ REFER TO BODY ILLUSTRATION SECTION 400

P-3964

A EXTERIOR Moulding ILLUSTRATION SECTION

FORD CAR PARTS

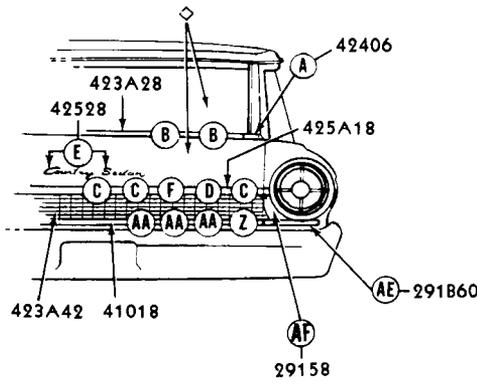
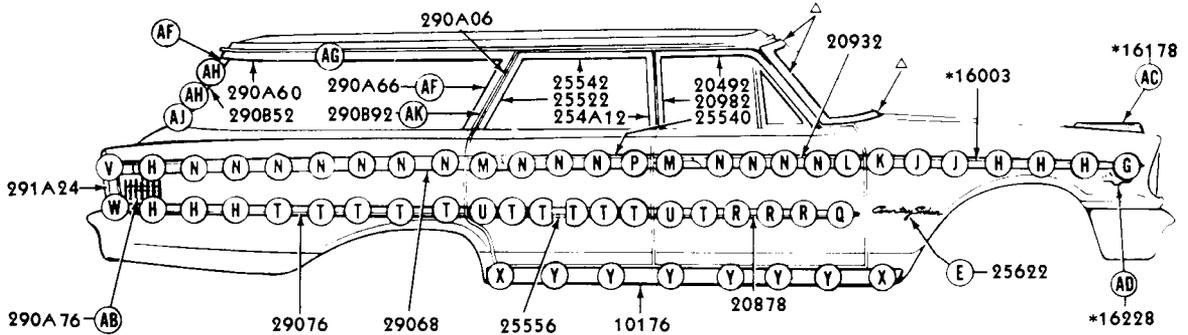

- A** *52718-S
- B** C2MY-71423A26-A
- C** C3AZ-7142527-A
- D** C3AZ-7142527-B
- E** 375890-S (MM-222-A)
- F** 376792-S (MM-191-D)
- G** C2OZ-6240368-A
- H** C3AZ-6229120-A
- I** *C3AZ-16A076-B OR C
- J** 376792-S (MM-191-D)
- K** *C3AZ-16A076-C OR D OR C3AZ-6220884-B OR C
- L** C3AZ-6220884-B OR C
- M** 350002-S (BB-529)
- N** C3AZ-6229108-A
- O** 350002-S (BB-529)
- P** C3AZ-5425034-A
- Q** C3AZ-6220884-A OR D
- R** C3AZ-6221020-A
- S** 359606-S (MM-291-A)
- T** 376792-S (MM-191-D)
- U** C3AZ-6221066-A
- V** C3AZ-6229185-A
- W** *C3AB-7129374-A
- X** *C2YB-62102A78-A
- Y** C2AZ-5410182-A
- Z** C1AB-59425A36-A
- AA** C3AZ-71407A12-A
- AB** 375480-S (MM-222-E)
- AC** 354397-S (MM-291)
- AD** 353577-S (MM-222)
- AE** *C3AB-71291864-A

ALTERNATES
*C3AZ-62290882-A

- AF** 376378-S (UU-97)
- AG** 41540-S (U-353)
- AH** *55731-S
- AJ** *C1AB-59291A14-A
- AK** C1AZ-5929100-A
- AC** 354397-S (MM-291)
- AD** 353577-S (MM-222)
- AE** *C3AB-71291864-A
- AM** 377924-S
- AN** *376762-S
- AO** 45234-S (M-179)

△ REFER TO BODY ILLUSTRATION SECTION 030
◇ REFER TO BODY ILLUSTRATION SECTION 400
*REFER TO GROUP IN CHASSIS SECTION P-3965

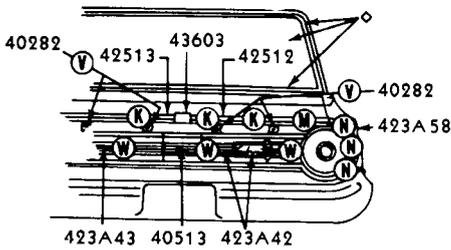
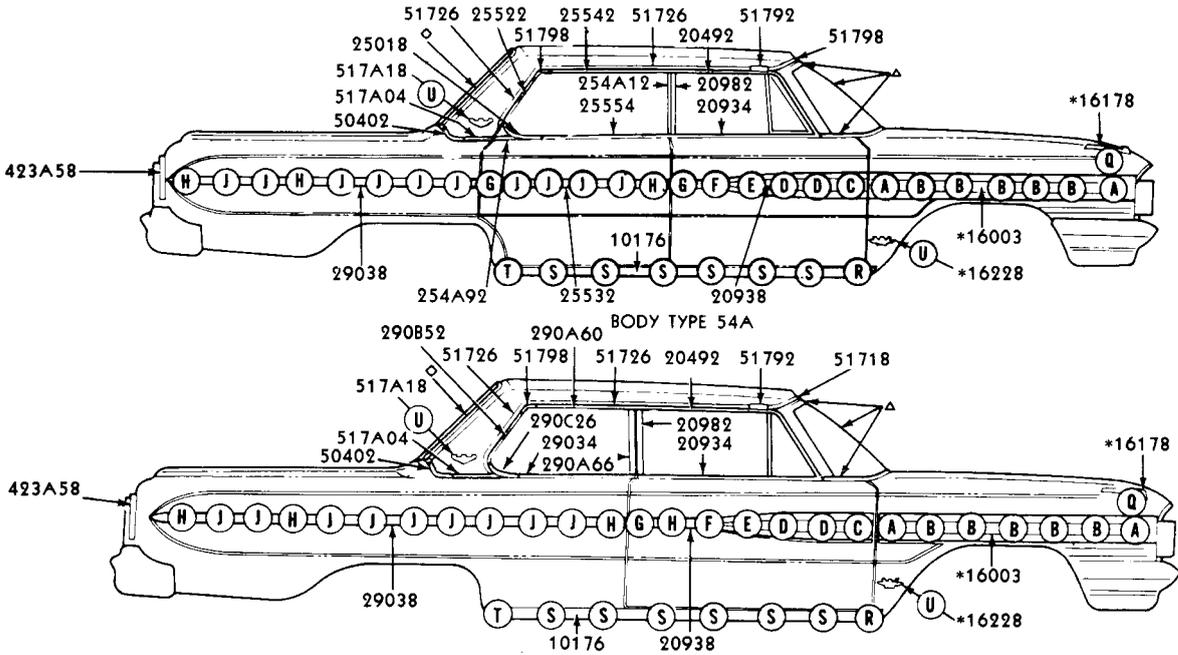

- 353911-S (MM-191-E)
- 353911-S (MM-191-E)
- C4AZ-6220884-A
- 376792-S (MM-191-D)
- 359606-S (MM-291-A)
- 359606-S (MM-291-A)
- 40282
- 42513
- 43603
- 42512
- 40282
- 423A58
- 423A43
- 40513
- 423A42
- *C4AZ-16A076-A
- *C4AZ-16A076-B
- C4AZ-6220884-B
- C4AZ-6221060-A
- 359606-S (MM-291-A)
- 350002-S (BB-529)
- 359606-S (MM-291-A)
- C4AZ-6221094-A
- C4AZ-6221066-A
- C4AZ-6220880-A
- C4AZ-6229120-A
- 359606-S (MM-291-A)
- 380144-S (BB-541-H)
- C4AZ-6242527-B
- C4AZ-6242527-A
- C4AZ-6242527-D
- 376792-S (MM-191-D)
- *C2YB-62102A78-A
- C4AZ-6210182-A
- 353911-S (MM-191-E)
- *34160-S
- *378470-S
- 375480-S (MM-222-E)
- 378362-S (MM-228)
- C4AZ-62423A64.C
- ◇ REFER TO BODY ILLUSTRATION SECTION 400
- △ REFER TO BODY ILLUSTRATION SECTION 030
- * REFER TO GROUP IN CHASSIS SECTION

A EXTERIOR Moulding
II ILLUSTRATION SECTION

FORD CAR PARTS

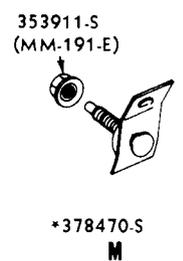
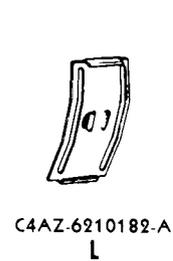
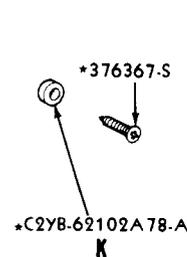
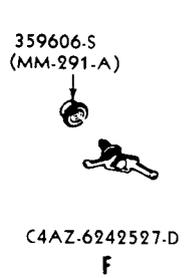
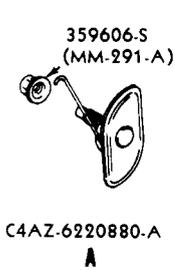
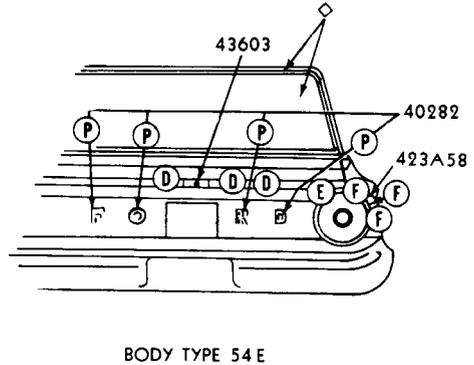
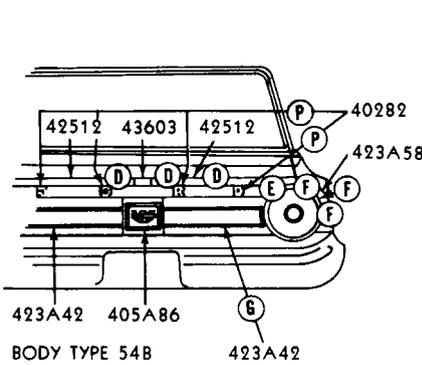
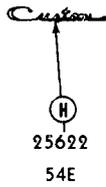
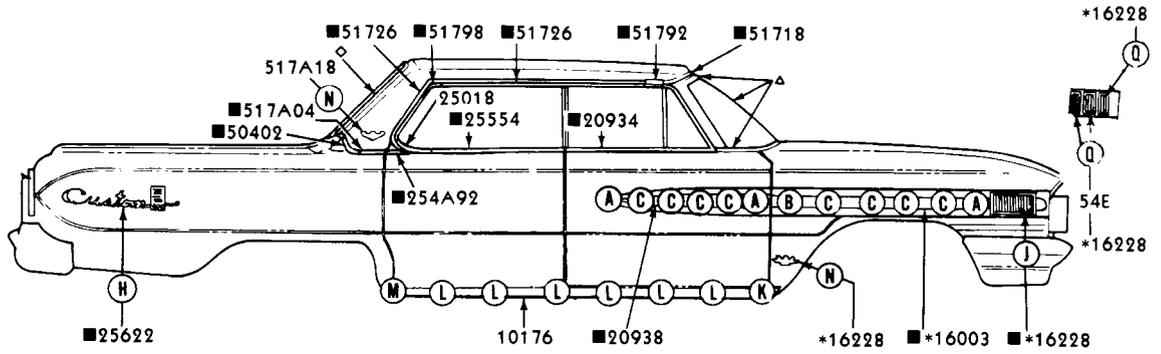

◇ REFER TO BODY ILLUSTRATION SECTION 400
 △ REFER TO BODY ILLUSTRATION SECTION 030
 * REFER TO GROUP IN CHASSIS SECTION
 ■ BODY TYPE 54B

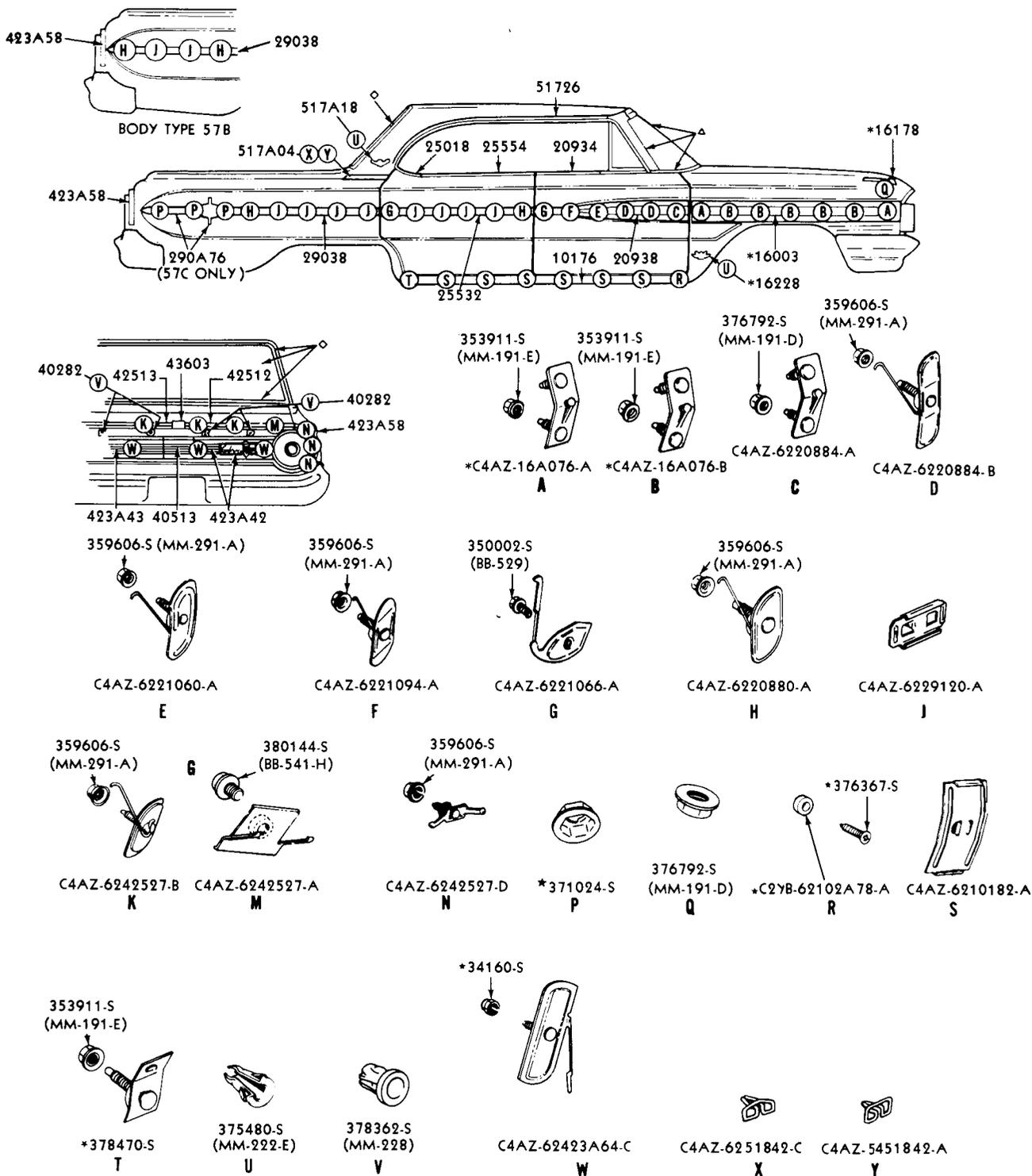

◇REFER TO BODY ILLUSTRATION SECTION 400
 △REFER TO BODY ILLUSTRATION SECTION 030
 *REFER TO GROUP IN CHASSIS SECTION

**A EXTERIOR MOULDING
ILLUSTRATION SECTION**

FORD CAR PARTS

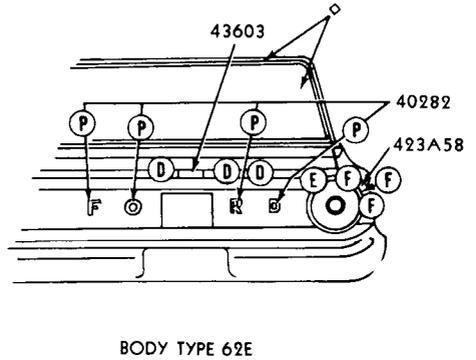
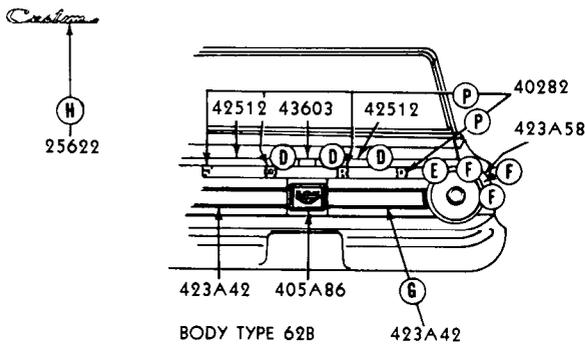
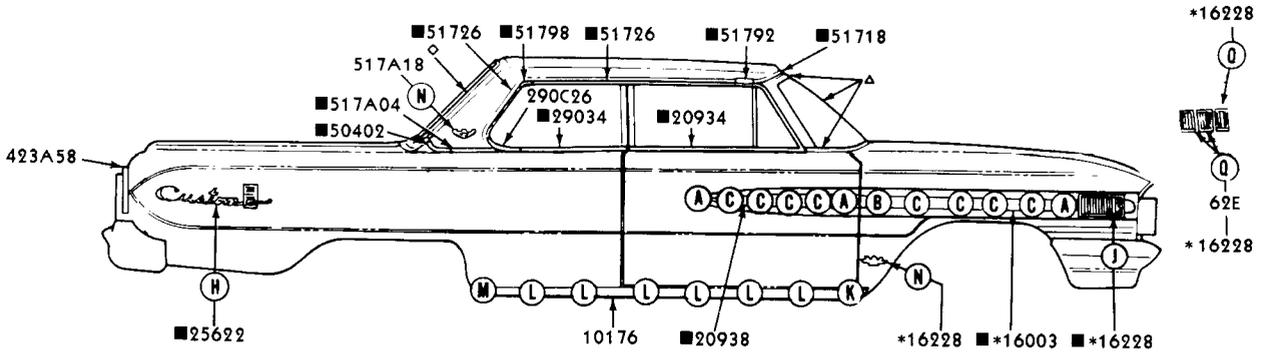

C4AZ-6220880-A
A



*C4AZ-16A076-C
B



C4AZ-6229120-A
C

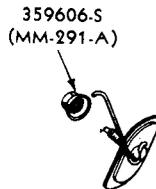

C4AZ-6242527-B
D



C4AZ-6242527-A
E

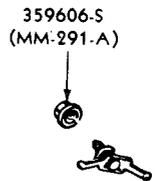

C4AZ-6242527-D
F

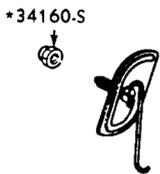

C4AZ-62423A64-B
G



375890-S
(MM-222-A)
H



*372855-S
J



*C2YB-62102A78-A
K



C4AZ-6210182-A
L

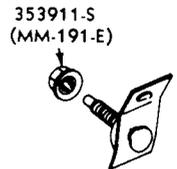

*378470-S
M



375480-S
(MM-222-E)
N



378362-S
(MM-228)
P



371024-S
(MM-286)
Q

■ BODY TYPE 62B
 ◇ REFER TO BODY ILLUSTRATION SECTION 400
 △ REFER TO BODY ILLUSTRATION SECTION 030
 * REFER TO GROUP IN CHASSIS SECTION

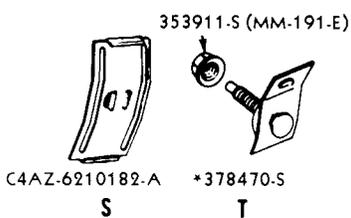
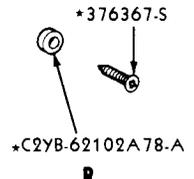
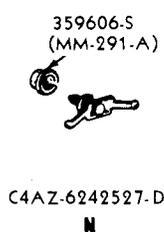
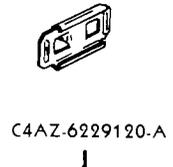
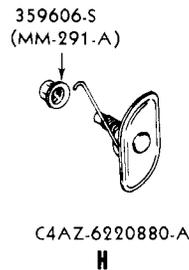
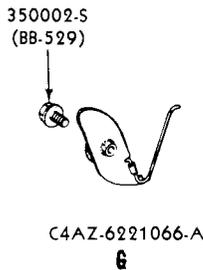
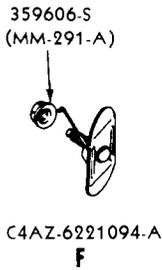
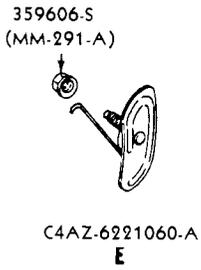
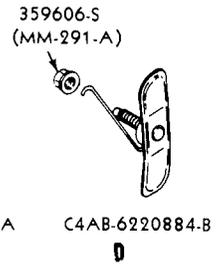
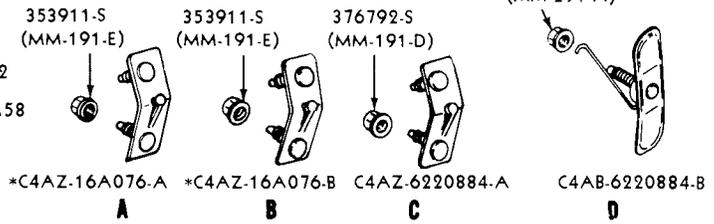
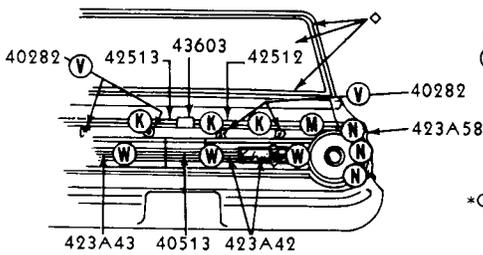
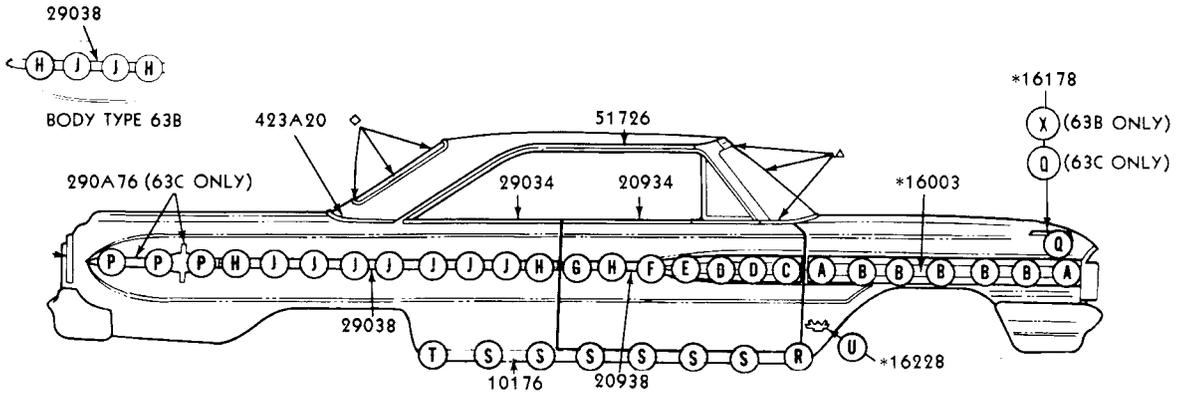

◇ REFER TO BODY ILLUSTRATION SECTION 400
 △ REFER TO BODY ILLUSTRATION SECTION 030
 * REFER TO GROUP IN CHASSIS SECTION

**A EXTERIOR Moulding
ILLUSTRATION SECTION**

FORD CAR PARTS

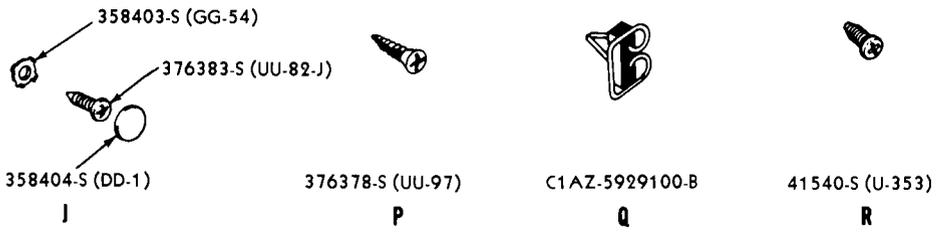
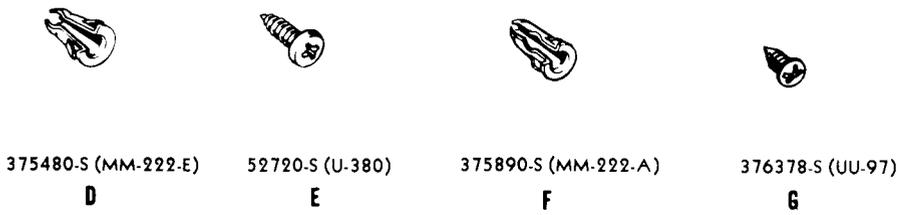
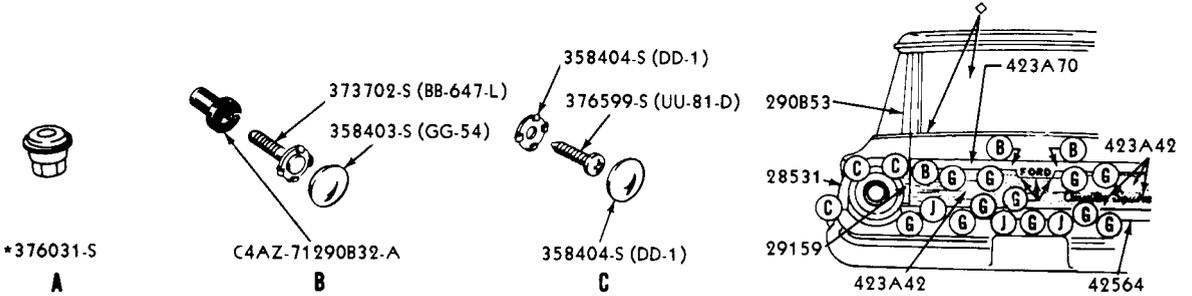
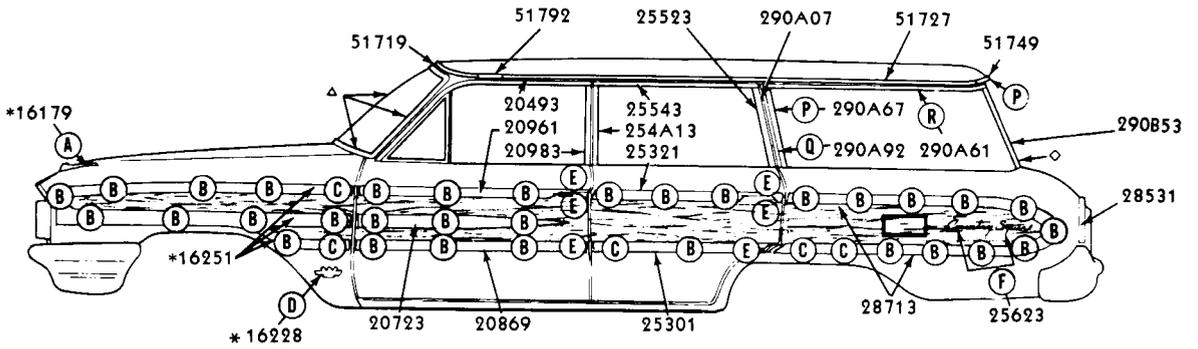

△ REFER TO BODY ILLUSTRATION SECTION 030
 ◇ REFER TO BODY ILLUSTRATION SECTION 400
 * REFER TO GROUP IN CHASSIS SECTION
 WALNUT GRAIN TRANSFER REFER TO BODY GROUP 20748

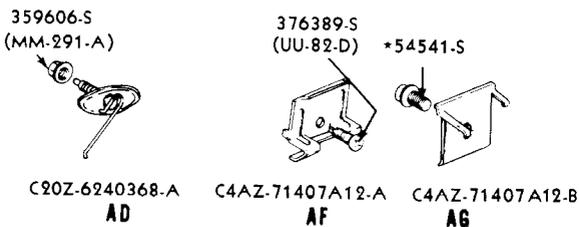
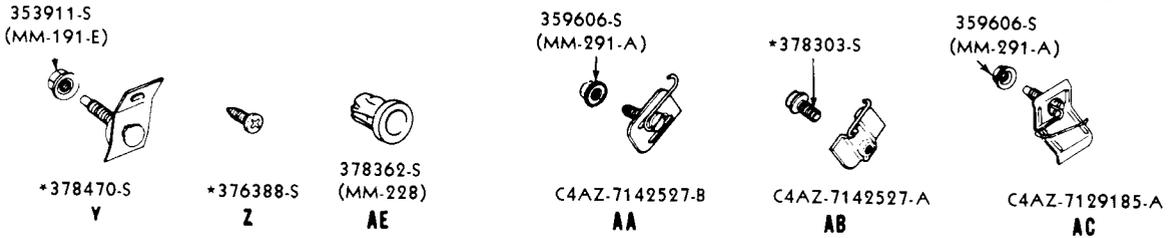
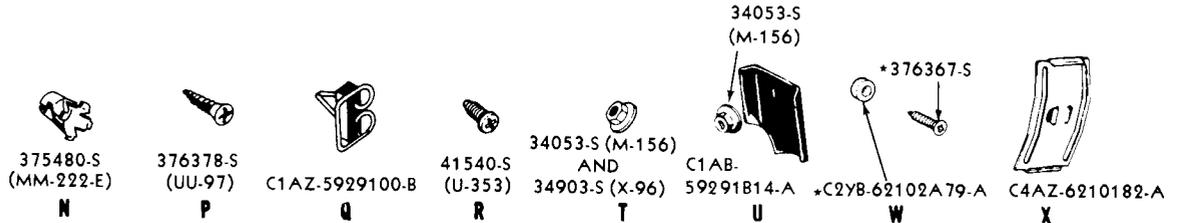
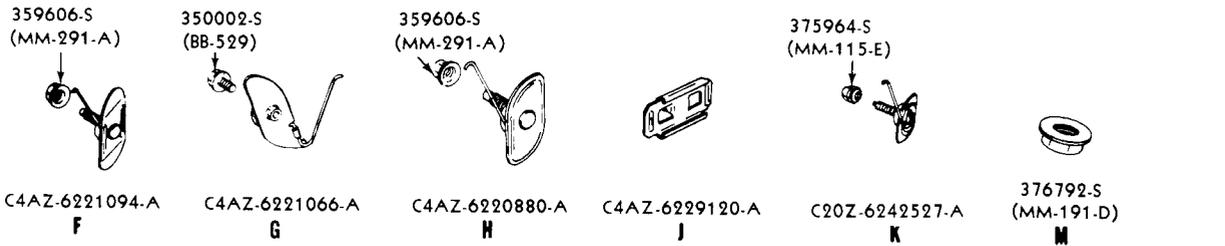
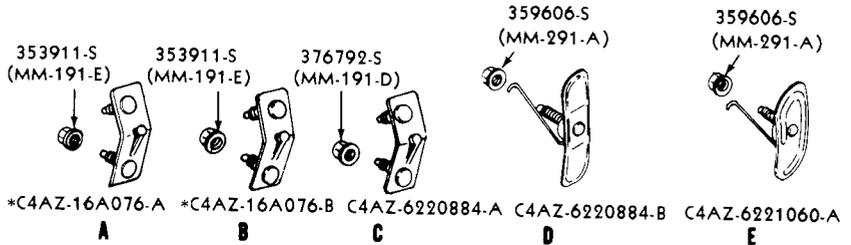
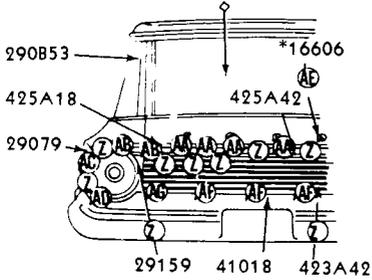
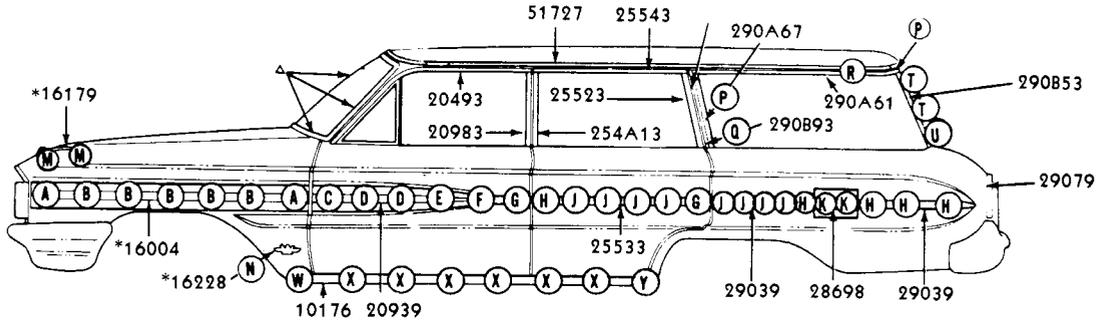

◇ REFER TO BODY ILLUSTRATION SECTION 400
 △ REFER TO BODY ILLUSTRATION SECTION 030
 * REFER TO GROUP IN CHASSIS SECTION

**A EXTERIOR MOULDING
ILLUSTRATION SECTION**

FORD CAR PARTS

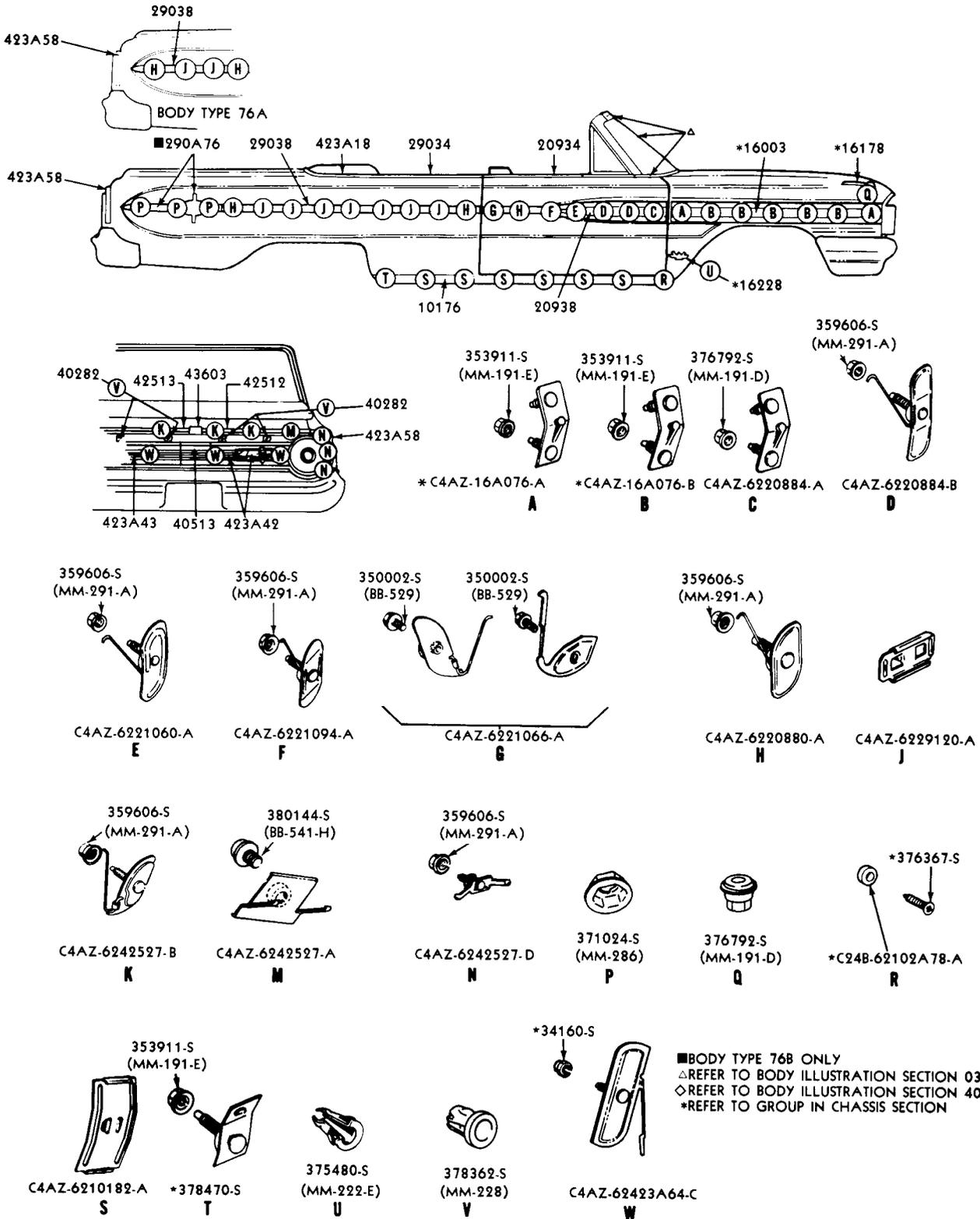

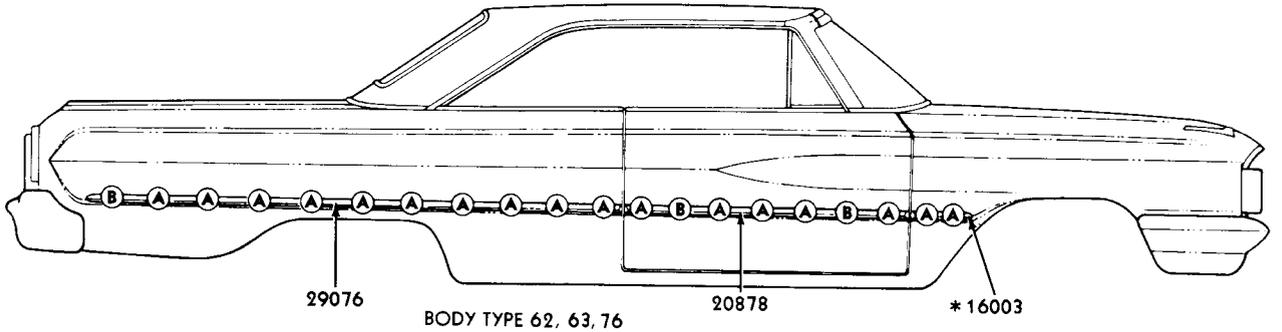

COMPLETE UNIT KIT C4AZ 6221048-A

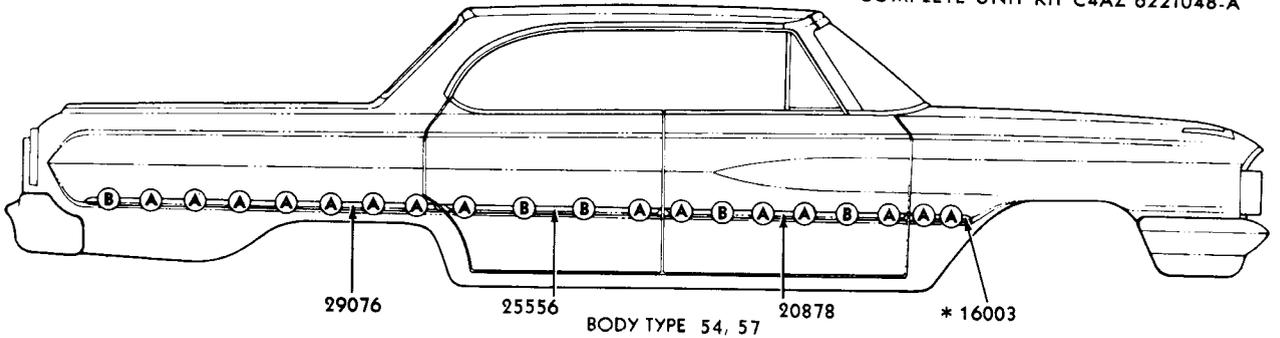

COMPLETE UNIT KIT C4AZ 5421048-A

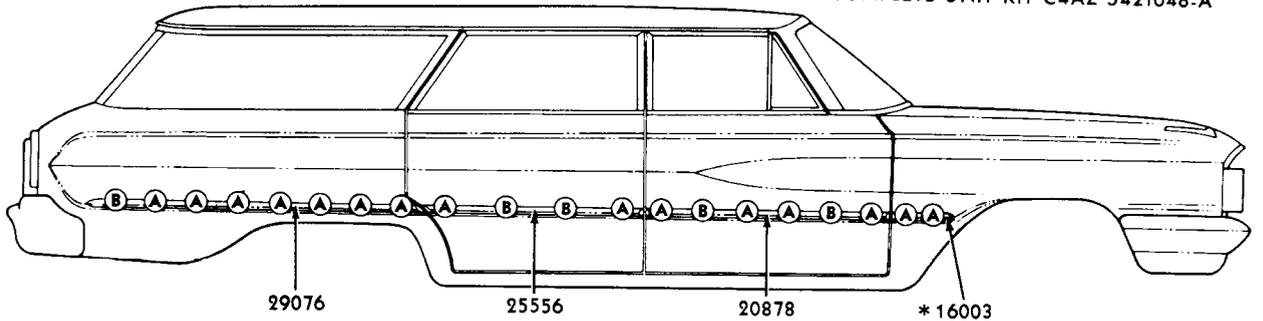

COMPLETE UNIT KIT C4AZ 7121048-A

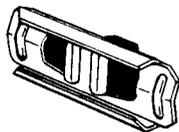

C2DZ 6420842-A

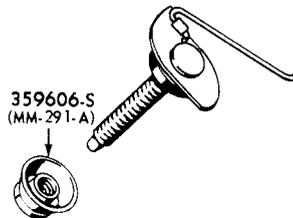

C2DZ 16A076-A

A

B

*REFER TO GROUP IN CHASSIS SECTION

**B EXTERIOR Moulding
ILLUSTRATION SECTION**

FORD CAR PARTS

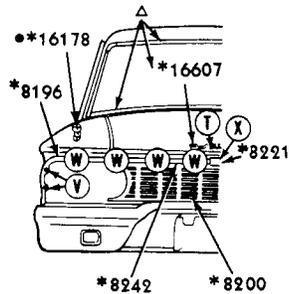
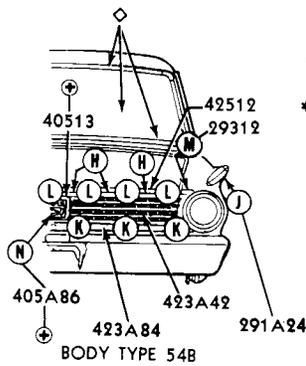
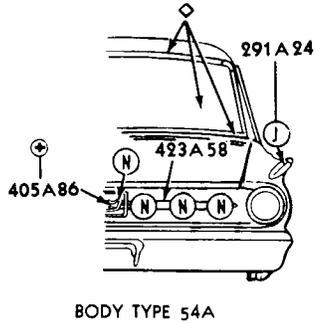
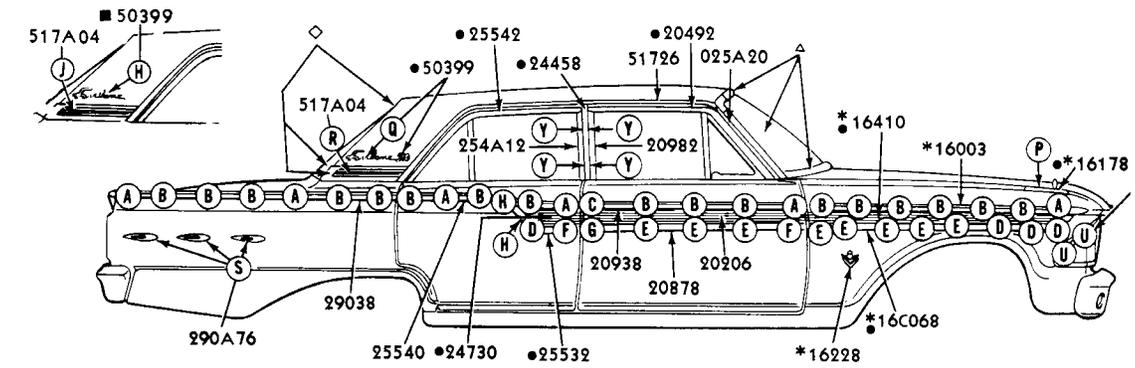

C20Z-6229120-A

B



C20Z-6221066-B

C

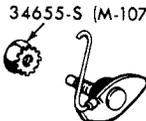

*C20Z-16A076-C

D

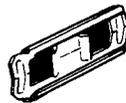

*C20Z-16A076 A

E

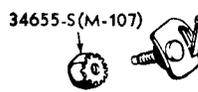

C20Z-6220884-A

F

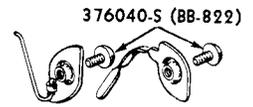

ALTERNATES
C20Z 6221066-A

G



376378-S (UU-97)

H



373265-S7 (MM-291-D)

J

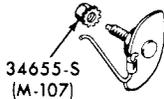

C20Z-6240368-A

K



C20Z-6242527-A

L



373715-S (MM-172)

M



373052-S (BB-556)

N



370548-S (MM-295)

P



375890-S (MM-222-A)

Q



375526-S (MM-295-H)

R



374073-S (MM-118)

S



55731-S (M-96-E)

T

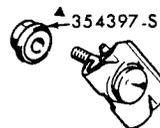

*C20Z-8B097-A

U



52727-S (U-382)

V



*C20Z-8244-A

W



354397-S (MM-291)

X



376374-S (BB-99)

Y

* REFER TO GROUP IN CHASSIS SECTION
△ REFER TO BODY ILLUSTRATION SECTION 030

■ BODY TYPE 54A

● BODY TYPE 54B

⊙ REFER TO BODY ILLUSTRATION SECTION 400

⊕ ALSO REFER TO BODY ILLUSTRATION SECTION 430

10-68

P-3755

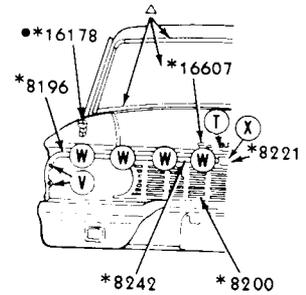
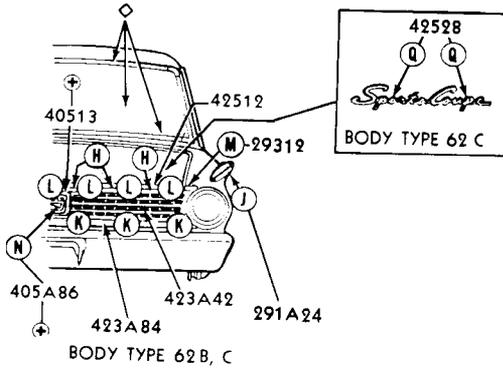
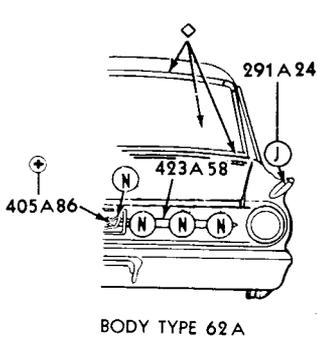
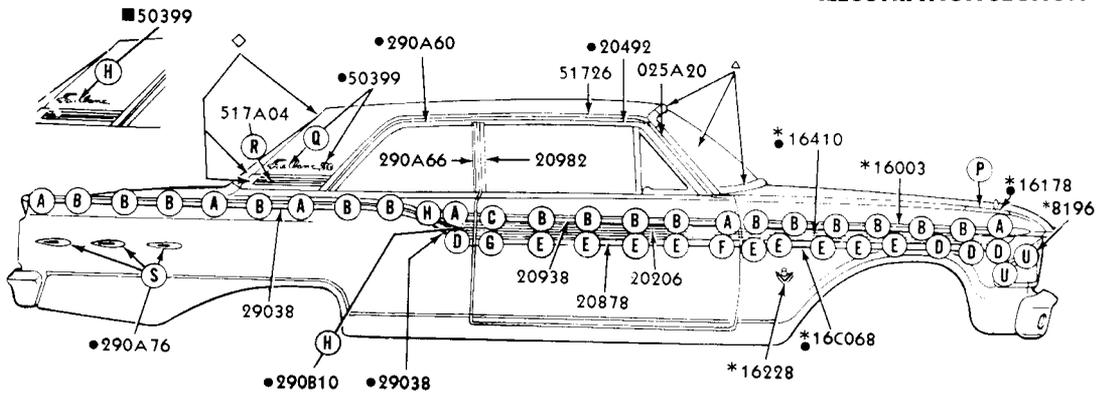

- | | | | | | |
|--------------------------------|--------------------------------|----------------------------------|----------------------------------|----------------------------------|--------------------------------|
| <p>C20Z-6221094-A
A</p> | <p>C20Z-6229120-A
B</p> | <p>C20Z-6221066-B
C</p> | <p>*C2DZ-16A076-C
D</p> | <p>*C20Z-16A076-A
E</p> | <p>C20Z-6220884-A
F</p> |
| <p>C20Z 6221066-A
G</p> | <p>376378-S (UU-97)
H</p> | <p>373265-S (MM-291-D)
J</p> | <p>C20Z-6240368-A
K</p> | <p>C20Z-6242527-A
L</p> | |
| <p>373715-S (MM-172)
M</p> | <p>373052-S (BB-556)
N</p> | <p>370548-S (MM-295)
P</p> | <p>375890-S (MM-222-A)
Q</p> | <p>375526-S (MM-295-H)
R</p> | <p>374073-S (MM-118)
S</p> |
| | | | | <p>55731-S (MM-96-E)
T</p> | <p>*C20Z-8B097-A
U</p> |
| | | | <p>52727-S (U-382)
V</p> | <p>*C20Z-8244-A
W</p> | <p>354397-S (MM-291)
X</p> |

* REFER TO GROUP IN CHASSIS SECTION
 △ REFER TO BODY ILLUSTRATION SECTION 030
 ◇ REFER TO BODY ILLUSTRATION SECTION 400
 † ALSO REFER TO BODY ILLUSTRATION SECTION 430
 ● BODY TYPE 62B, C
 ■ BODY TYPE 62A

B EXTERIOR MOULDING ILLUSTRATION SECTION

FORD CAR PARTS

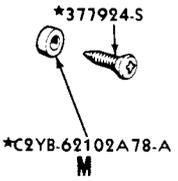
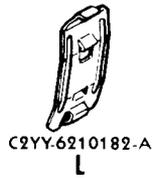
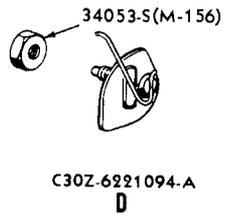
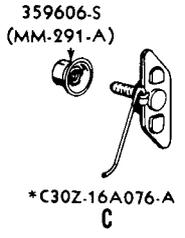
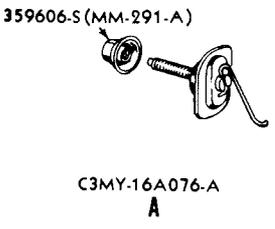
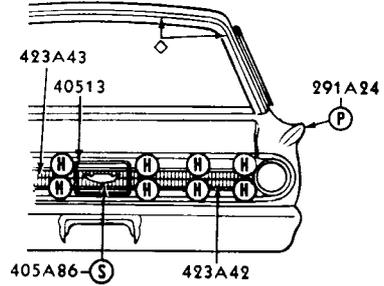
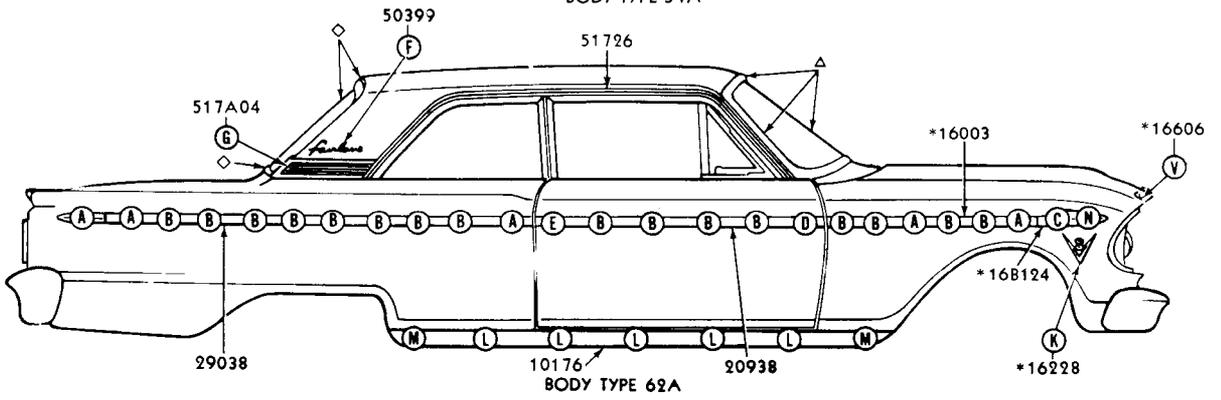
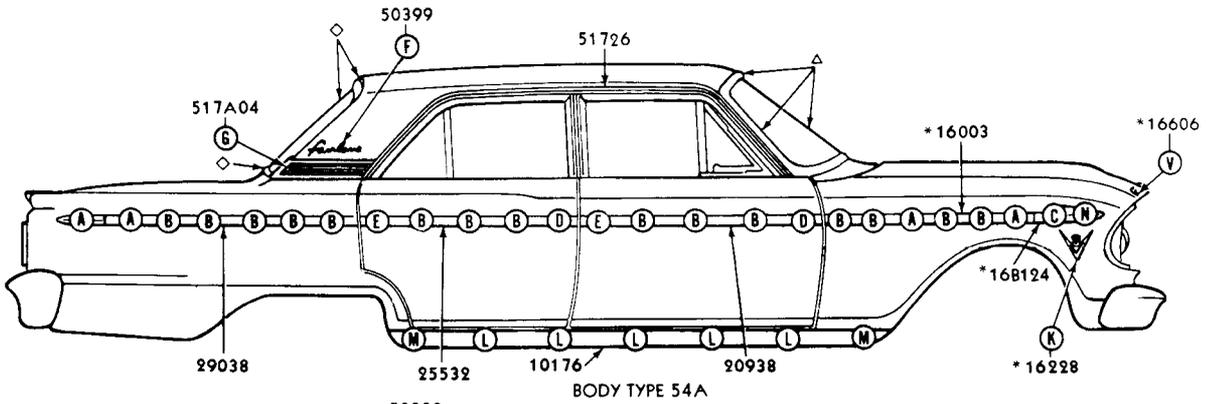

△REFER TO BODY ILLUSTRATION SECTION 030
◇REFER TO BODY ILLUSTRATION SECTION 400
*REFER TO GROUP IN CHASSIS SECTION

P-3966

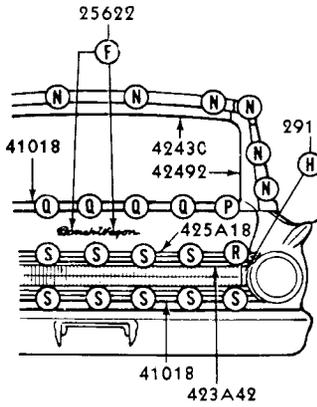
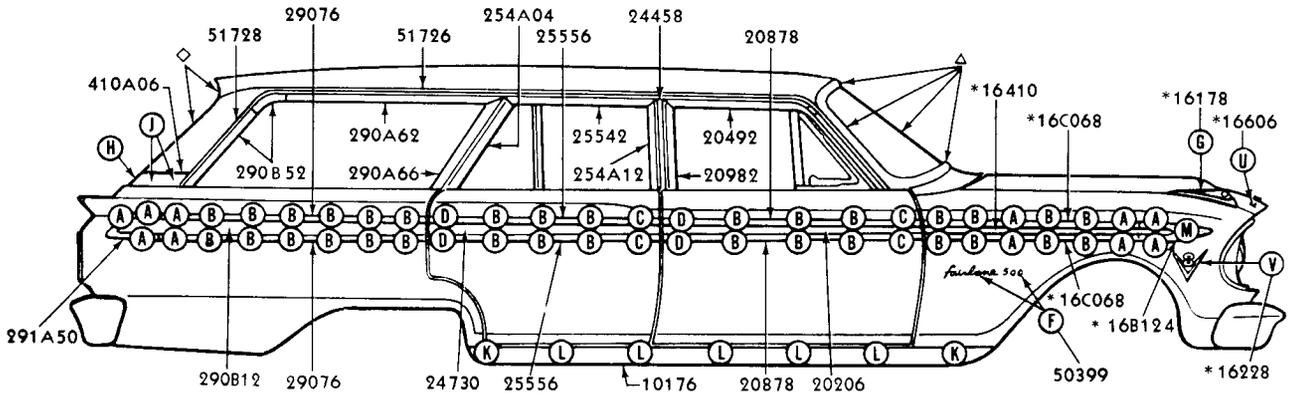

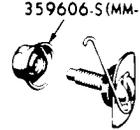
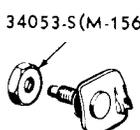
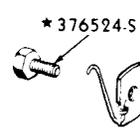
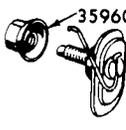
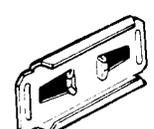
- 359606-S (MM-291-A)  **A**
- *C2DZ-16A076-C  **B**
- 34053-S (M-156)  **C**
- C20Z-6220884-A  **D**
- *376524-S  **E**
- C2SZ-6320880-B  **F**
- 375890-S (MM-222-A)  **G**
- 354397-S (MM-191)  **H**
- 376378-S (UU-97)  **I**
- *377924-S  **J**
- 359606-S (MM-291-A)  **K**
- *C2YB-62102A78-A  **L**
- C2YY-6210182-A  **M**
- *C30Z-16A076-C  **N**
- 52445-S (U-317)  **O**
- 376390-S (BB-820)  **P**
- C30Z-71407A12-A  **Q**
- *376524-S  **R**
- C30Z-71407A12-B  **S**
- 373265-S (MM-291-D)  **T**
- 375890-S (MM-222-A)  **U**
- 375480-S (MM-222-E)  **V**

△ REFER TO BODY ILLUSTRATION SECTION 030

◇ REFER TO BODY ILLUSTRATION SECTION 400

*REFER TO GROUP IN CHASSIS SECTION

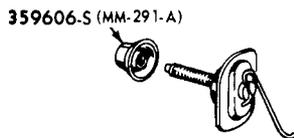
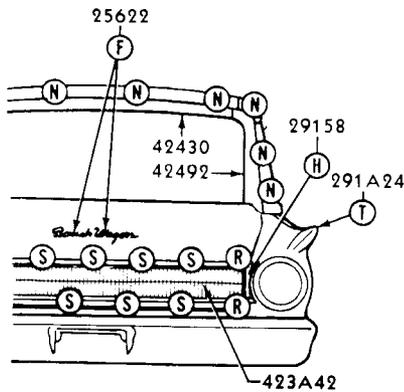
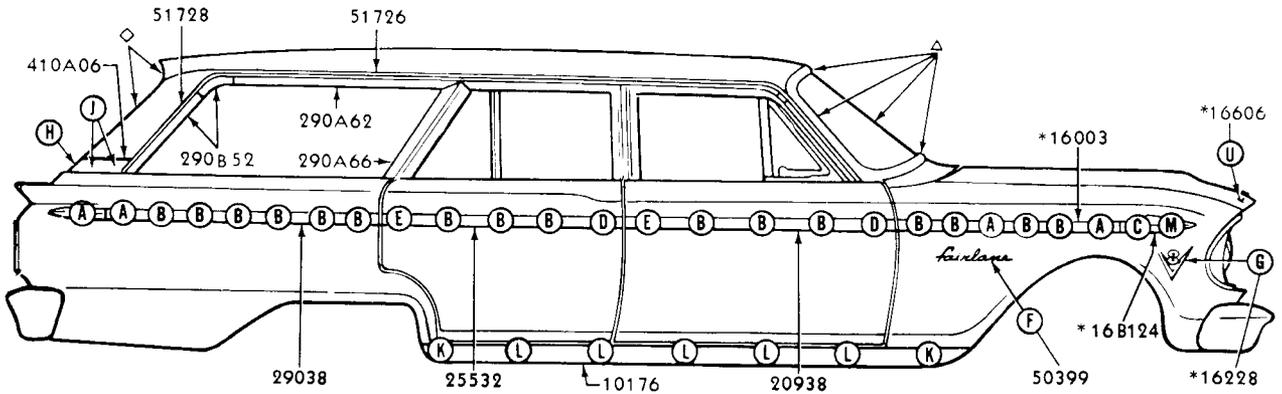

C3MY-16A076-A
A

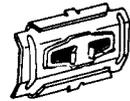

C3MY-6229108-A
B

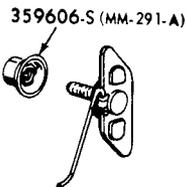

*C30Z-16A076-A
C

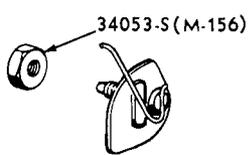

C30Z-6221094-A
D



*376524-S
E



375890-S (MM-222-A)
F



375480-S (MM-222-E)
G



376378-S (UU-97)
H



359606-S (MM-291-A)
J

*377924-S



*C2YB-62102A78-A
K



C2YY-6210182-A
L

359606-S (MM-291-A)



*C30Z-16A076-B
M



52445-S (U-317)
N



376792-S (MM-191-D)
R

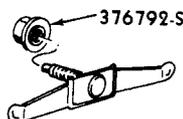

C30Z-7142527-A
S



373265-S (MM-291-E)
T



375890-S (MM-222-A)
U

△ REFER TO BODY ILLUSTRATION SECTION 030

◇ REFER TO BODY ILLUSTRATION SECTION 400

*REFER TO GROUP IN CHASSIS SECTION

P-4011

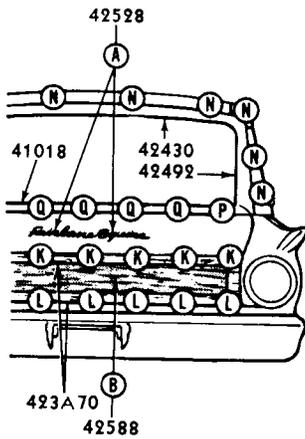
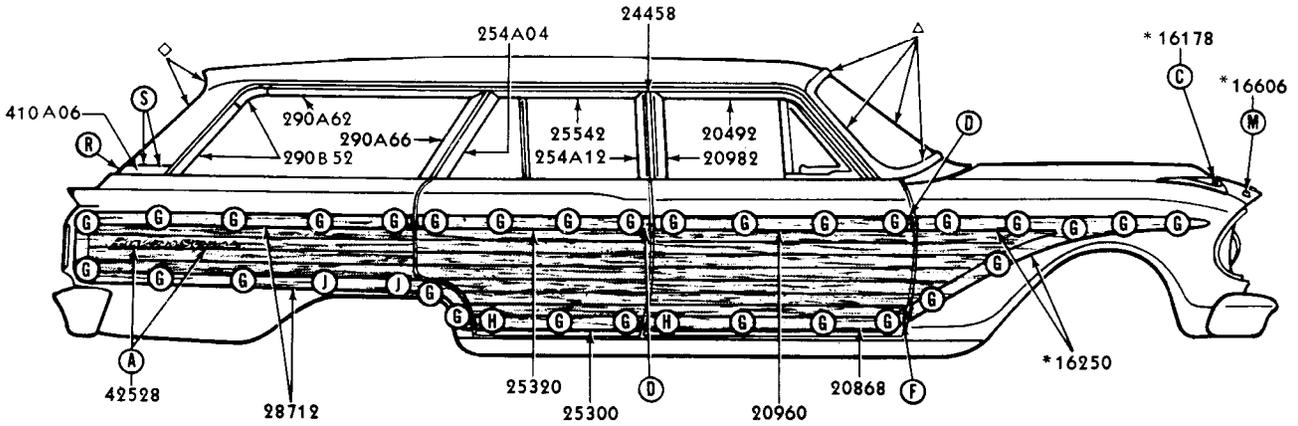

375890-S
(MM-222-A)
A



376389-S
(UU-82-D)
B



354397-S
(MM-191)
C



376599-S (UU-97)
D



350754-S (UU-86)
F

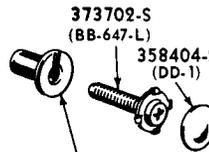

373702-S (BB-647-L)
B9AB-7150108-C
G

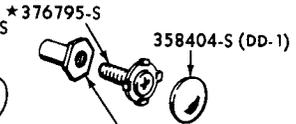

*376795-S
373181-S (MM-216)
H

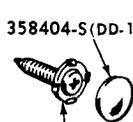

358404-S (DD-1)
376599-S (UU-81-D)
J



373702-S (BB-647-L)
358404-S (DD-1)
B9AB-7150108-B
K

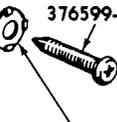

376599-S (UU-81-D)
358404-S (DD-1)
358403-S (GG-54)
L



375890-S
(MM-222-A)
M



52445-S (U-317)
N



376390-S
(BB-820)
P



C30Z-71407A12-A
Q



376378-S (UU-97)
R



359606-S (MM-291-A)
S

SIDE WALNUT GRAIN TRANSFER C30Z-7120748-A
TAIL GATE WALNUT GRAIN TRANSFER C30Z-7140722-A
FUEL FILLER LID TRANSFER C30Z-71405A02-A

*REFER TO GROUP IN CHASSIS SECTION
△ REFER TO BODY ILLUSTRATION SECTION 030
◇ REFER TO BODY ILLUSTRATION SECTION 400

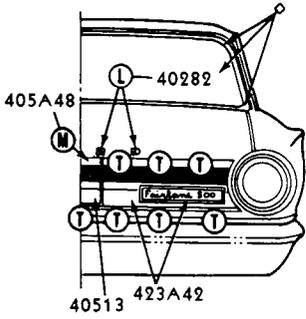
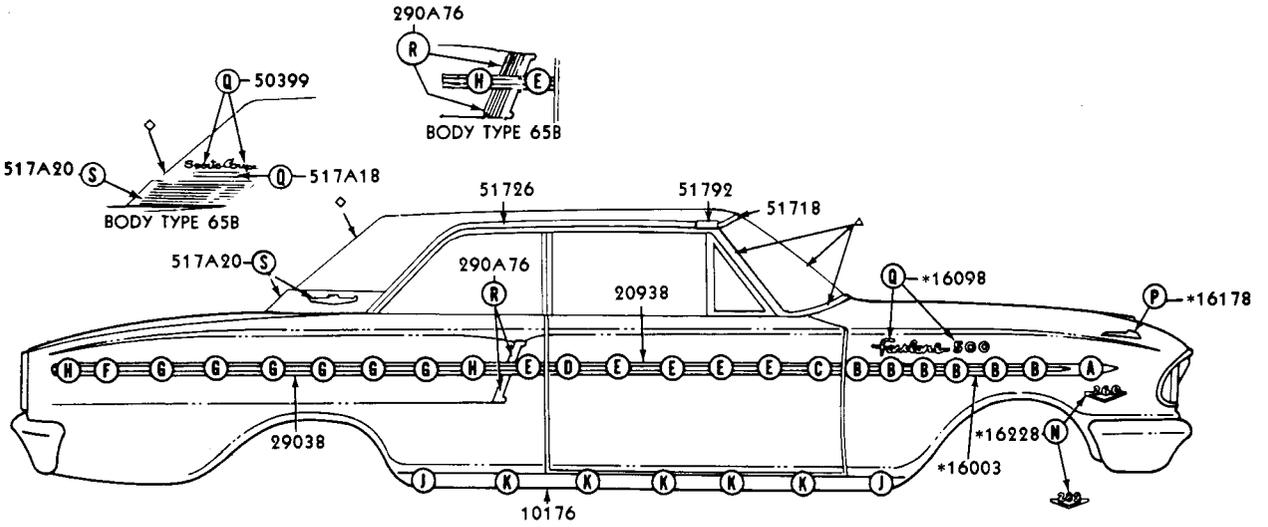

353911-S
(MM-191-E)



C40Z-6229120-A
A

353911-S
(MM-191-E)



C40Z-16A076-B
B

376792-S
(MM-191-D)



C40Z-6220884-B
C

376792-S
(MM-191-D)



C40Z-6220880-A
D

359606-S
(MM-291-A)

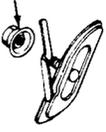

C40Z-6221094-C
E

359606-S
(MM-291-A)



C40Z-6229120-C
F



C40Z-6229120-B
G

359606-S
(MM-291-A)



*378419-S
H



*377924-S
*C2YB-62102A78-A
I



C2YY-6210182-A
K

378362-S
(MM-228)



L

40918-S
(U-260)



M

375480-S
(MM-222-E)



N

359606-S
(MM-291-A)



P

375890-S
(MM-222-A)



Q

371882-S
(MM-287)



R

375526-S
(MM-295-H)



S

377633-S
(MM-115-F)



*378419-S
T

△REFER TO BODY ILLUSTRATION SECTION 030
◇REFER TO BODY ILLUSTRATION SECTION 400
*REFER TO GROUP IN CHASSIS SECTION

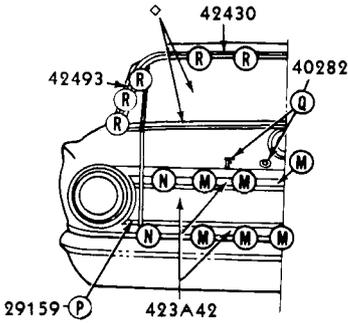
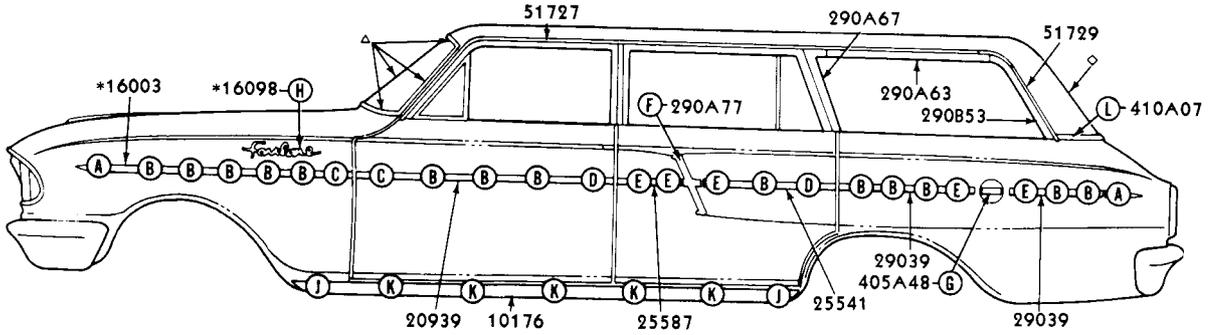

353911-S
(MM-191-E)



*C40Z-16A076-A
A

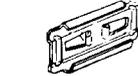

C40Z-6221094-A
B

376792-S
(MM-191-D)



C40Z-6220884-A
C

380144-S
(BB-541-H)



C40Z-6221094-B
D

353911-S
(MM-191-E)



C40Z-6229120-A
E



371882-S
(MM-287)
F



40917-S
(U-257)
G



375890-S
(MM-222-A)
H

*377924-S



*C2YB-62102A78-A
J



C2YY-6210182-A
K

45243-S
(M-178)

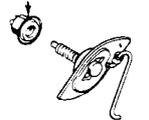

C30Z-71410A30-A
L

376792-S
(MM-191-D)



C30Z-7142527-A
M



350002-S
(BB-529)
N



376378-S
(UU-97)
P



378362-S
(MM-228)
Q



52445-S
(U-317)
R

△REFER TO BODY ILLUSTRATION SECTION 030
◇REFER TO BODY ILLUSTRATION SECTION 400
*REFER TO GROUP IN CHASSIS SECTION

P-4285

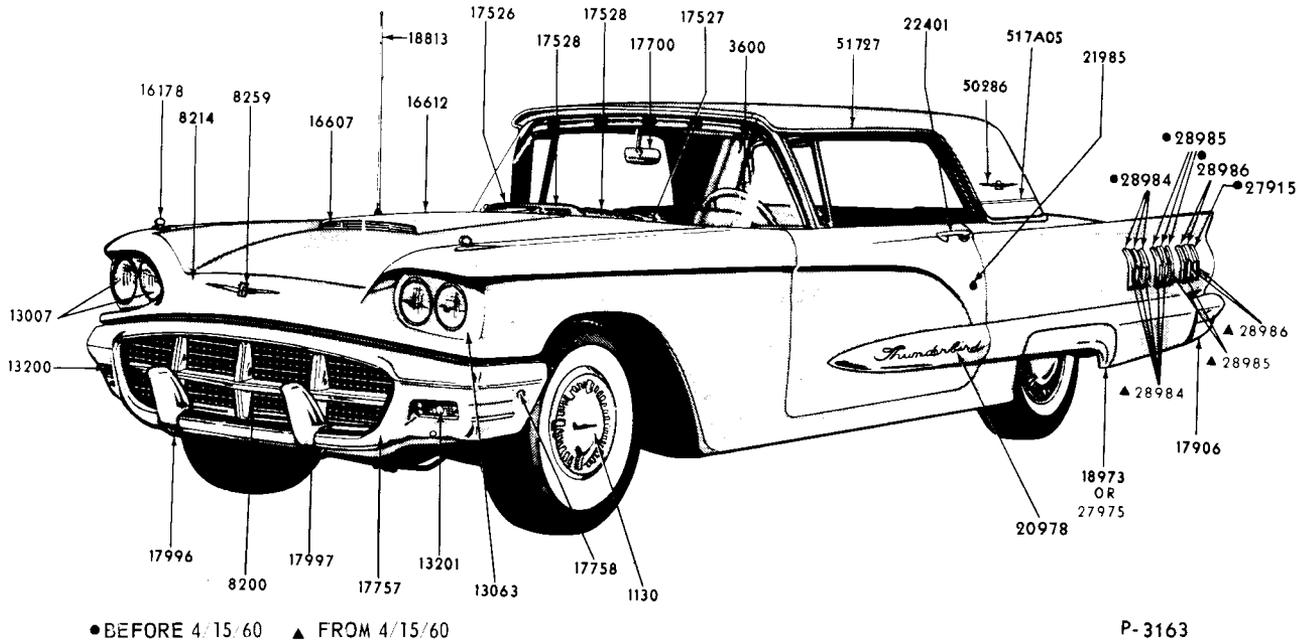

1960 THUNDERBIRD

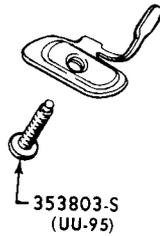
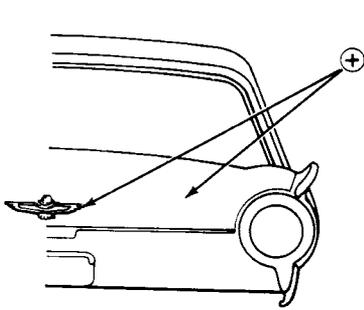
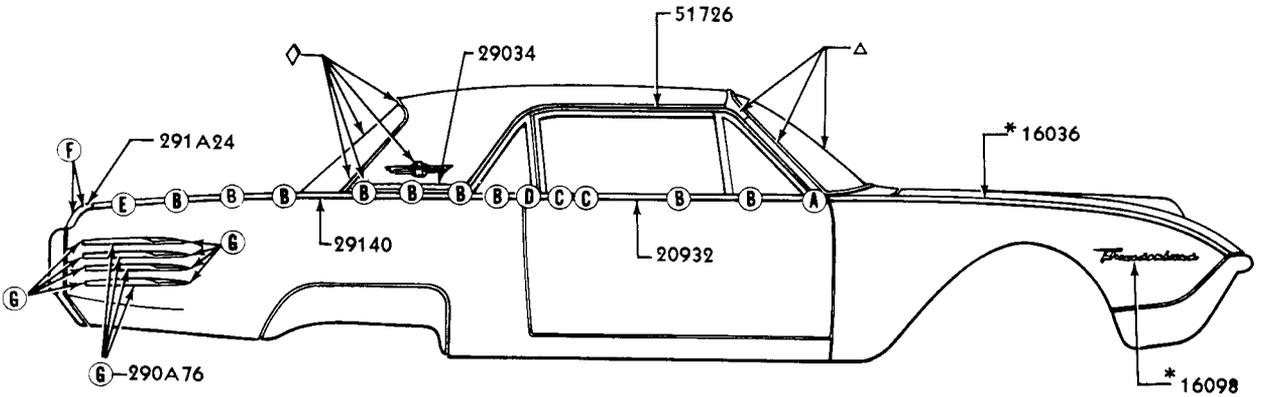

*C15B-6320232-A

A



C1AB6229144-A

B



353911-S
(MM-191-E)

C



354146-S
(UU-96)

D

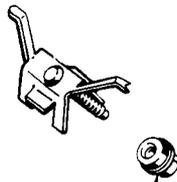

353911-S
(MM-191-E)
C1SZ-16A076

E



354397-S (MM-291)

F



373504-S
(MM-285-B)

G

* REFER TO GROUP IN CHASSIS SECTION
△ REFER TO BODY ILLUSTRATION SECTION 030

◇ REFER TO BODY ILLUSTRATION SECTION 400
⊕ REFER TO BODY ILLUSTRATION SECTION 430

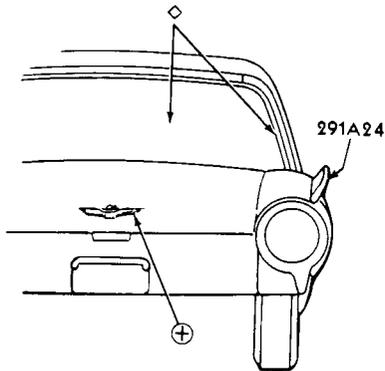
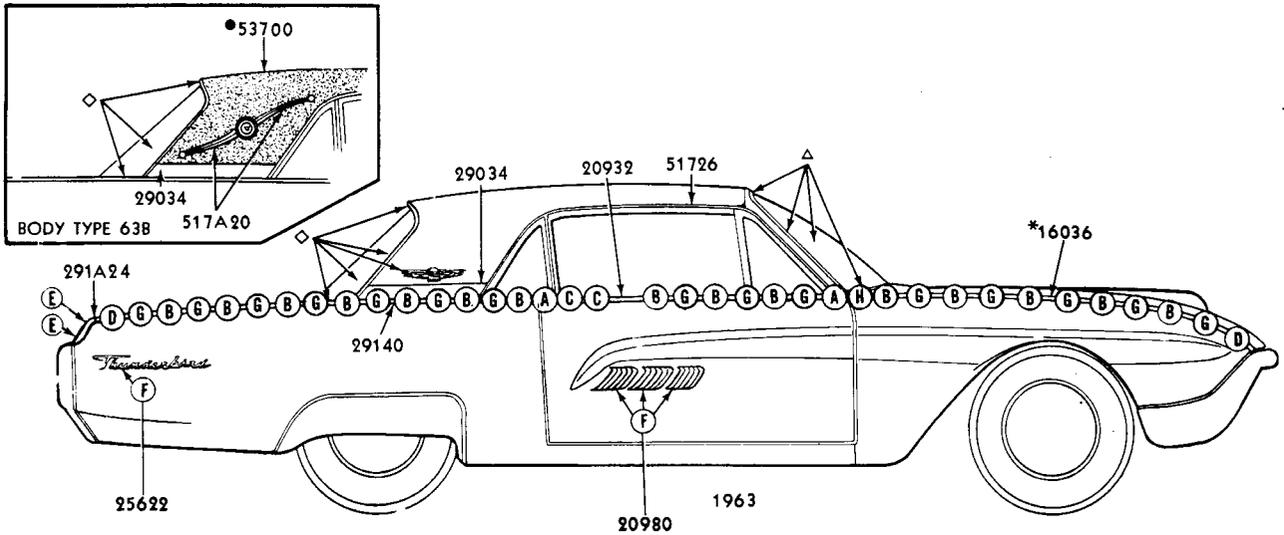
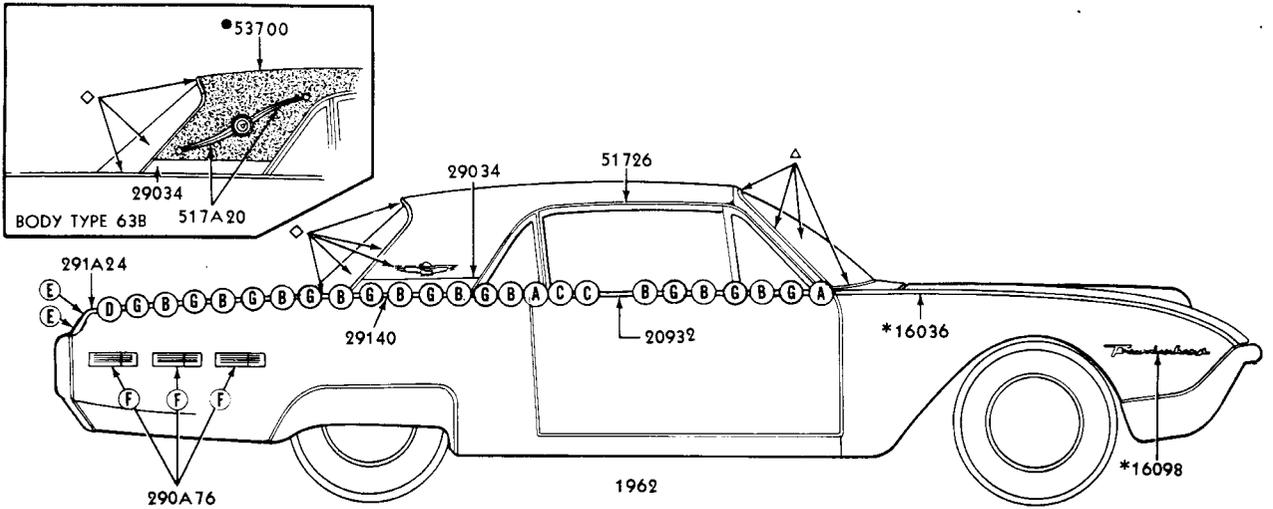

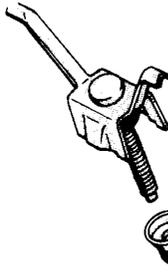
- 
52726-S (U-381)
A
- 
C1SZ-6329144-A
B
- 
359606-S (MM-291-A)
C
- 
359606-S (MM-291-A)
D
- 
353911-S (MM-191-E)
E
- 
373503-S (MM-285-A)
F
- 
C2SZ6329144-A
G
- 
376378-S (UU-97)
H

- * REFER TO GROUP IN CHASSIS SECTION
- △ REFER TO BODY ILLUSTRATION SECTION 030
- ◇ REFER TO BODY ILLUSTRATION SECTION 400
- ⊕ REFER TO BODY ILLUSTRATION SECTION 430
- REFER TO SOFT TRIM SECTION

376378-S (UU-97)

H

P-3987

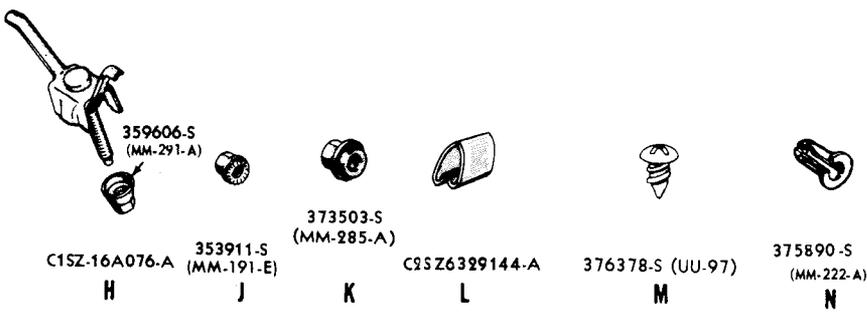
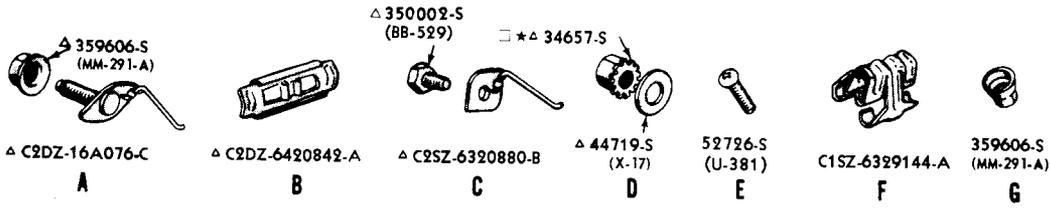
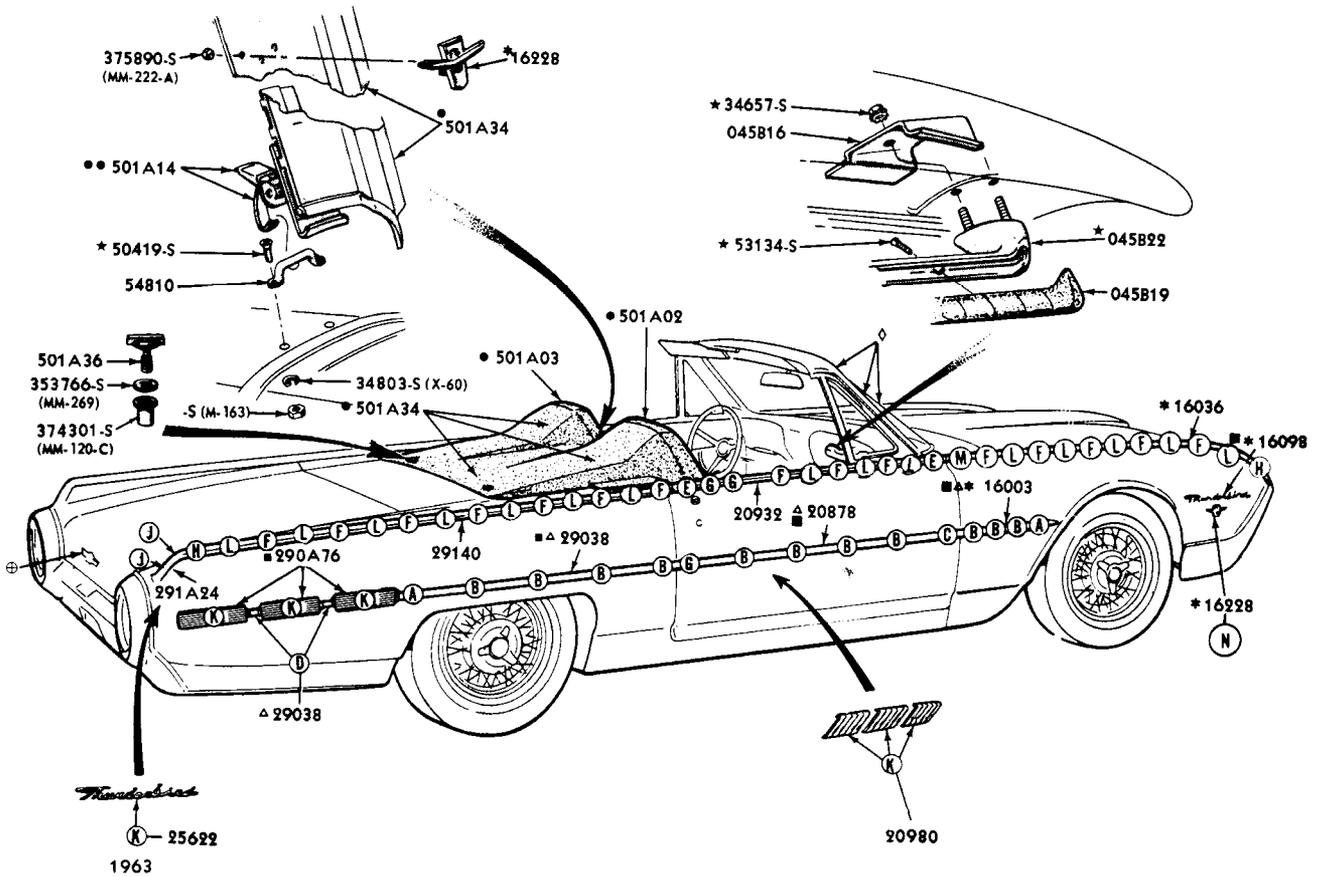

- 1962 ONLY
- * REFER TO GROUP IN CHASSIS SECTION
- ◇ REFER TO BODY ILLUSTRATION SECTION 030
- REFER TO SOFT TRIM SECTION
- FOR SERVICE USE 33795-S7(MM-49) & 34940-S7-8(X-88)
- △ ALSO INCLUDED IN SIDE SPORTS TRIM KIT 20000
- ALSO INCLUDED WITH 501A34
- ⊕ REFER TO BODY ILLUSTRATION SECTION 430

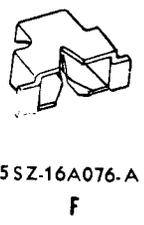
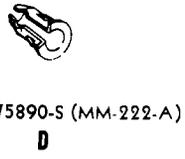
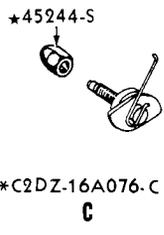
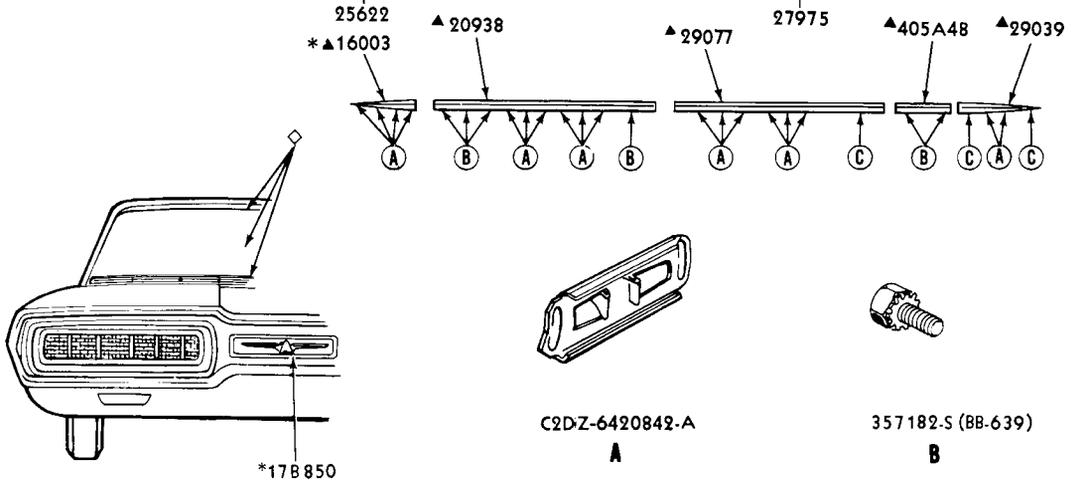
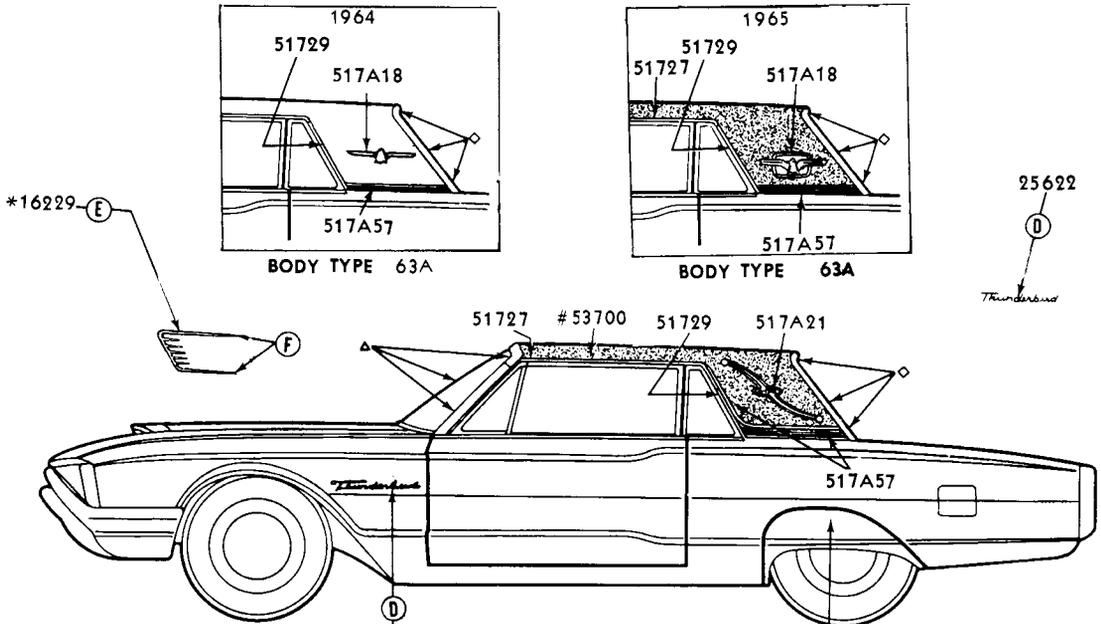

▲ REFER TO BODY ILLUSTRATION SECTION 030
◇ REFER TO BODY ILLUSTRATION SECTION 400
REFER TO SOFT TRIM SECTION
▲ ALSO SUPPLIED IN 21048 BODY SIDE MOULDING KIT
* REFER TO GROUP IN CHASSIS SECTION

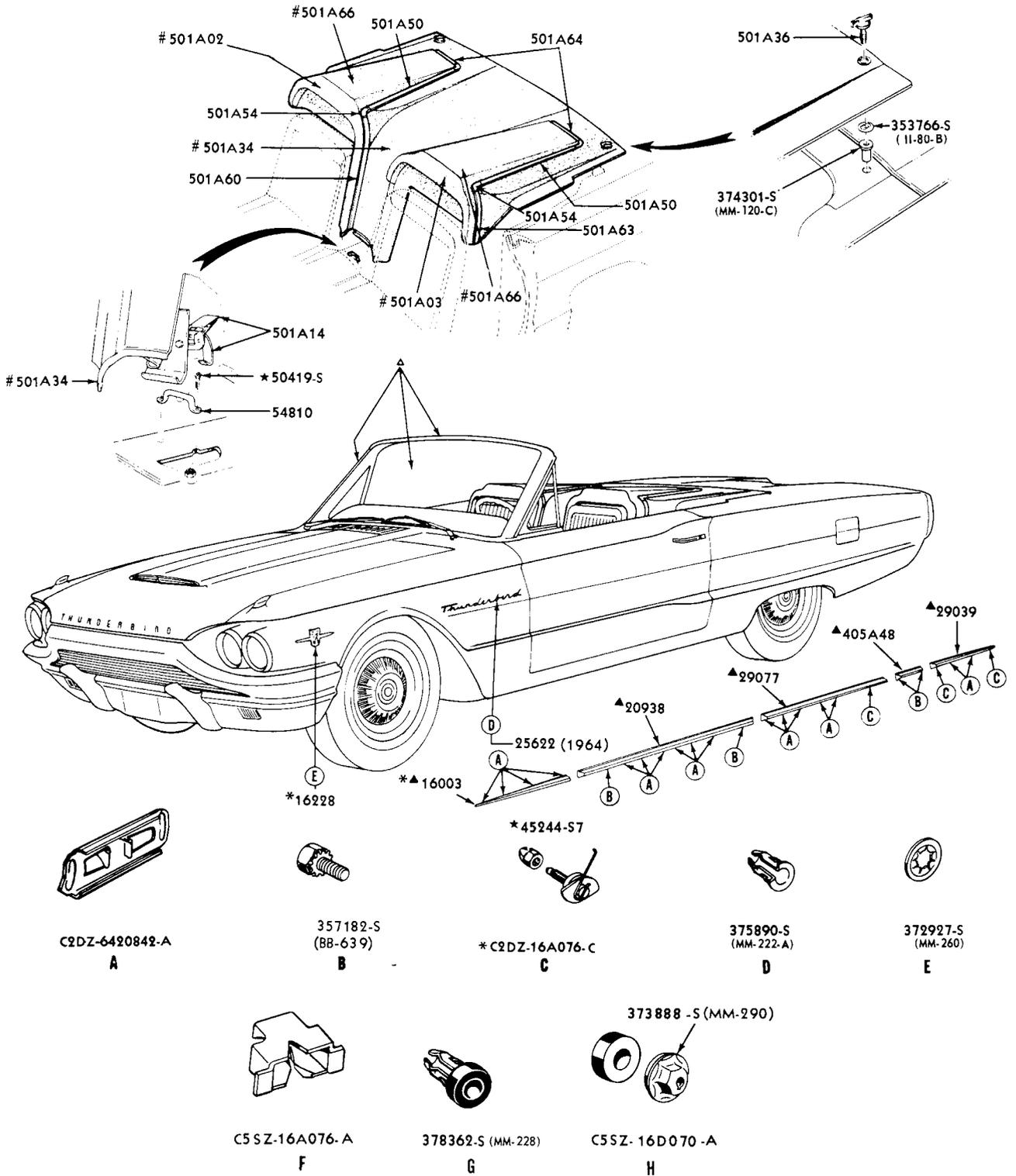

C2DZ-6420842-A
A

357182-S (BB-639)
B

*C2DZ-16A076-C
C

375890-S (MM-222-A)
D

372927-S (MM-260)
E

C5SZ-16A076-A
F

378362-S (MM-228)
G

C5SZ-16D070-A
H

▲ REFER TO BODY ILLUSTRATION SECTION 030
 ◊ REFER TO BODY ILLUSTRATION SECTION 400
 # REFER TO SOFT TRIM SECTION
 ▲ ALSO SUPPLIED IN C4SZ-6321048-A BODY SIDE MOULDING KIT
 * REFER TO GROUP IN CHASSIS SECTION

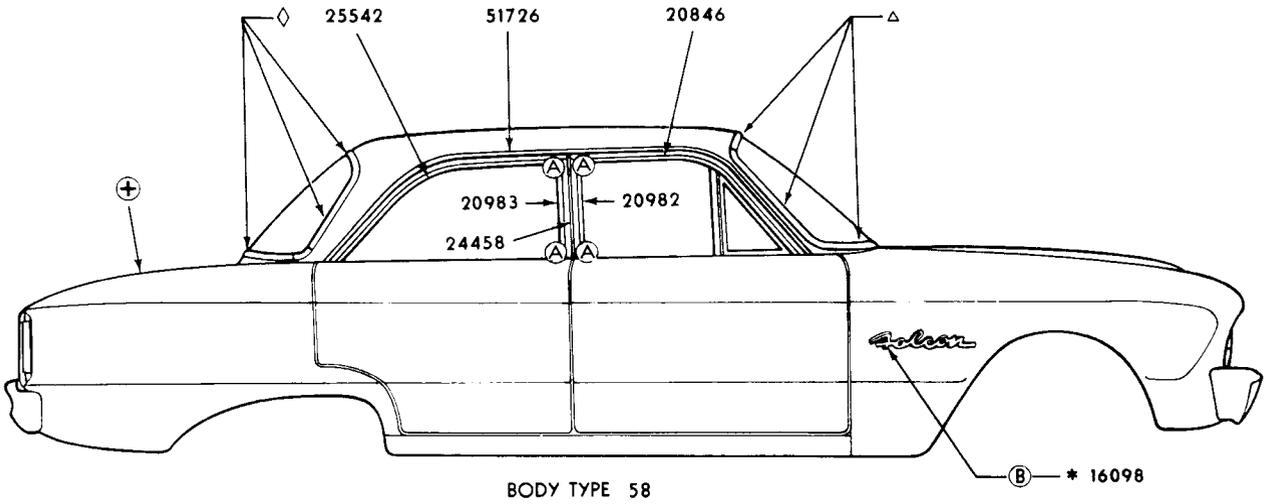

BODY TYPE 58

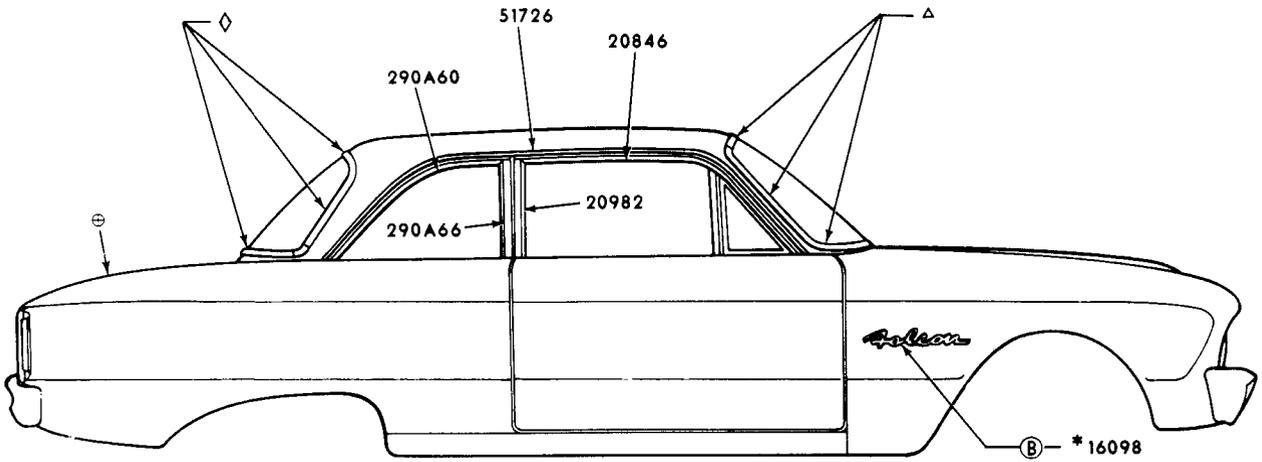

BODY TYPE 64



52336-S
(U-288) A



370713-S
(MM-292) B

* REFER TO GROUP IN CHASSIS SECTION
△ REFER TO BODY ILLUSTRATION SECTION 030

◇ REFER TO BODY ILLUSTRATION SECTION 400
⊕ REFER TO BODY ILLUSTRATION SECTION 430

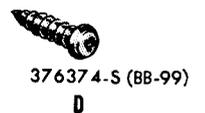
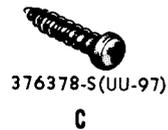
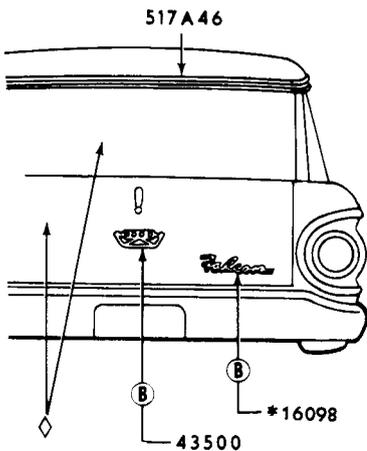
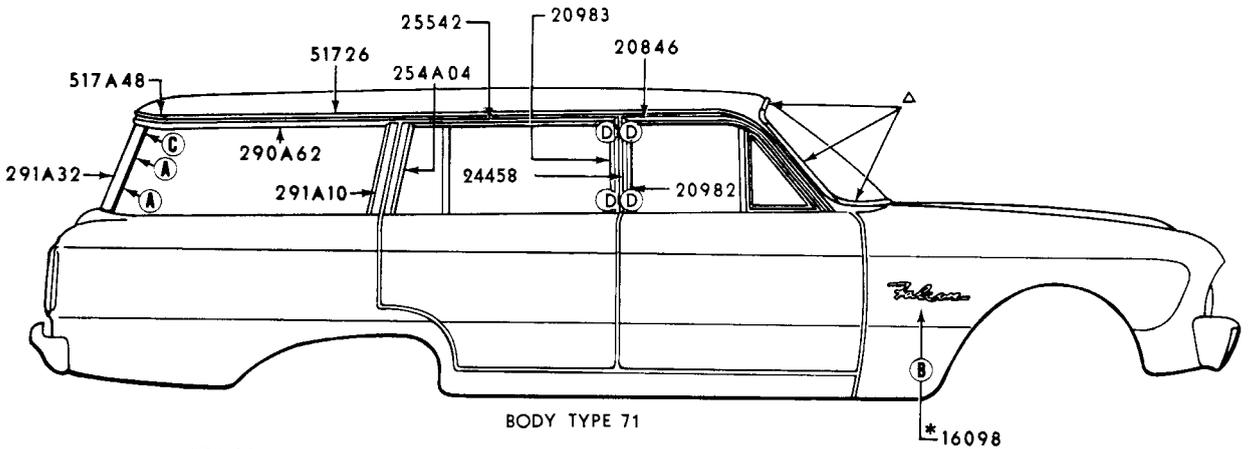
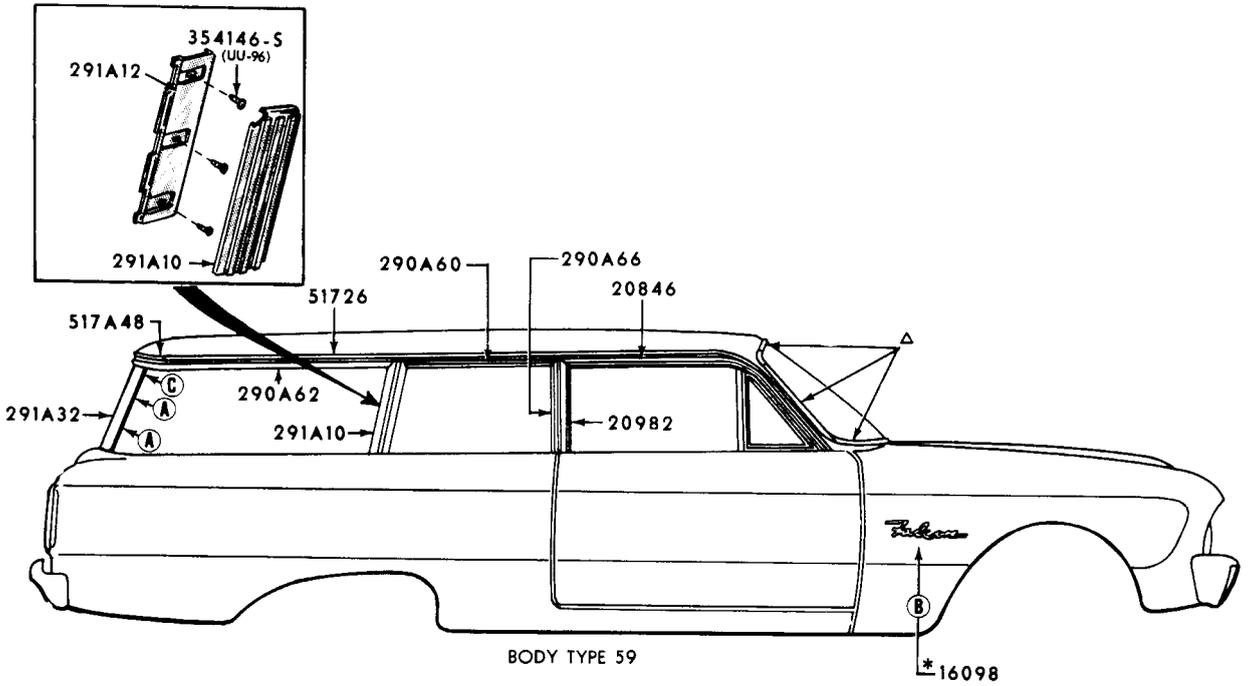

* REFER TO GROUP IN CHASSIS SECTION
 ▲ REFER TO BODY ILLUSTRATION SECTION 030
 ◇ REFER TO BODY ILLUSTRATION SECTION 400

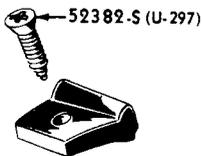
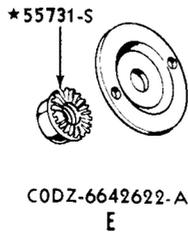
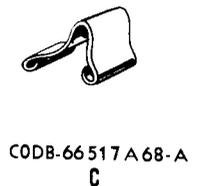
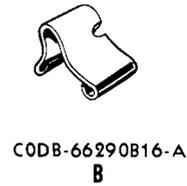
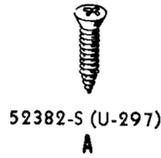
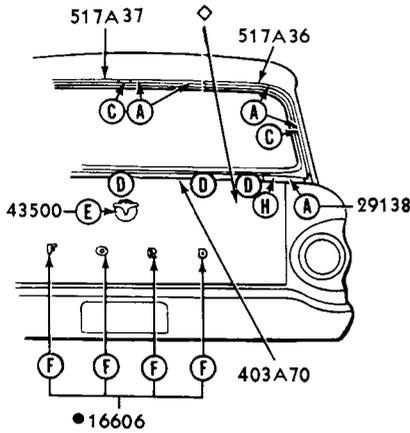
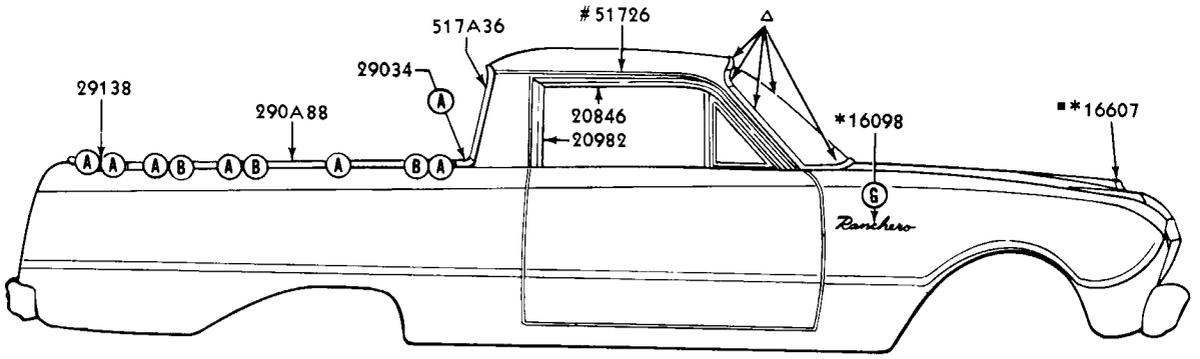

* REFER TO GROUP IN CHASSIS SECTION
 Δ REFER TO BODY ILLUSTRATION SECTION 030
 ◇ REFER TO BODY ILLUSTRATION SECTION 400
 # USED ON 1963 X(668) "FROM 6/19/63"
 ■ USE FOR 1962-3 ONLY

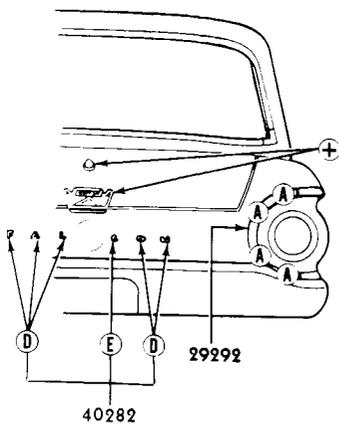
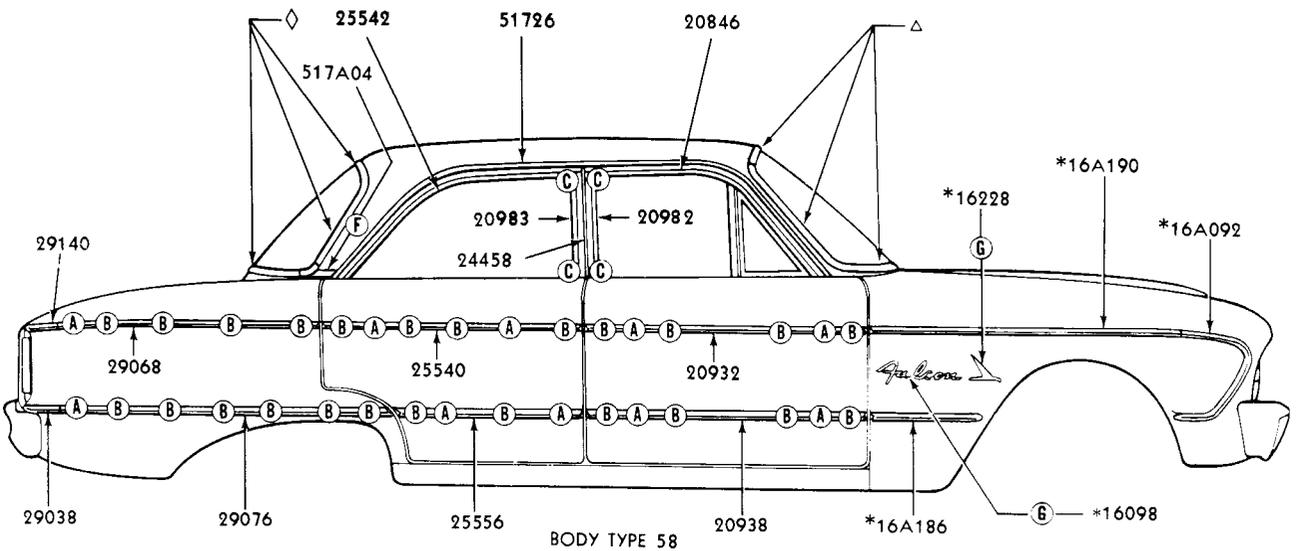
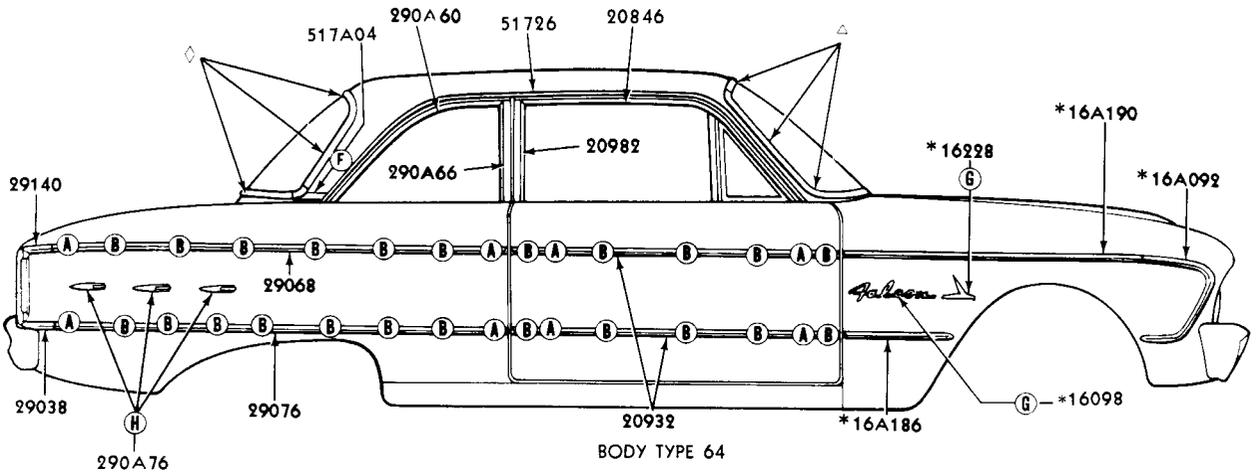

353911-S (MM-191-E)

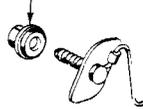

C2DZ-16A076-C

A

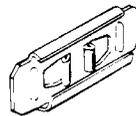

C2OZ-16A076-A

B



52336-S (U-288)

C



374046-S (MM-116)

D



353577-S (MM-222)

E



*C0DB 64517A60-A

F



370713-S (MM-292)

G



373504-S (MM-285-B)

H

* REFER TO GROUP IN CHASSIS SECTION
 △ REFER TO BODY ILLUSTRATION SECTION 030

◇ REFER TO BODY ILLUSTRATION SECTION 400
 ⊕ REFER TO BODY ILLUSTRATION SECTION 430

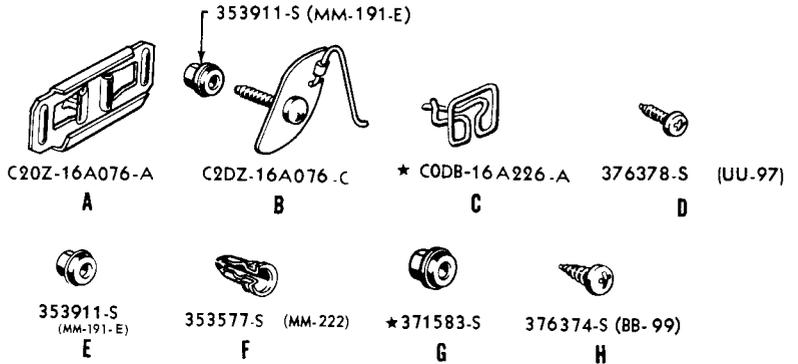
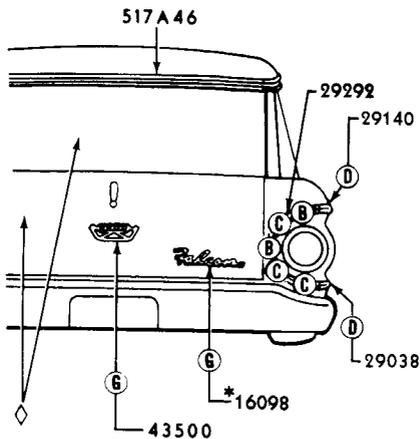
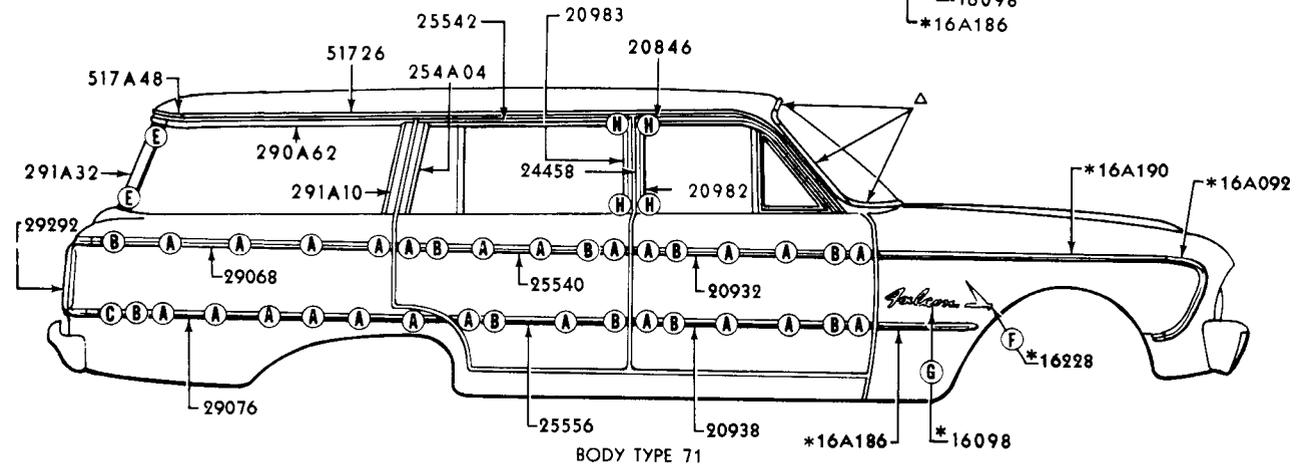
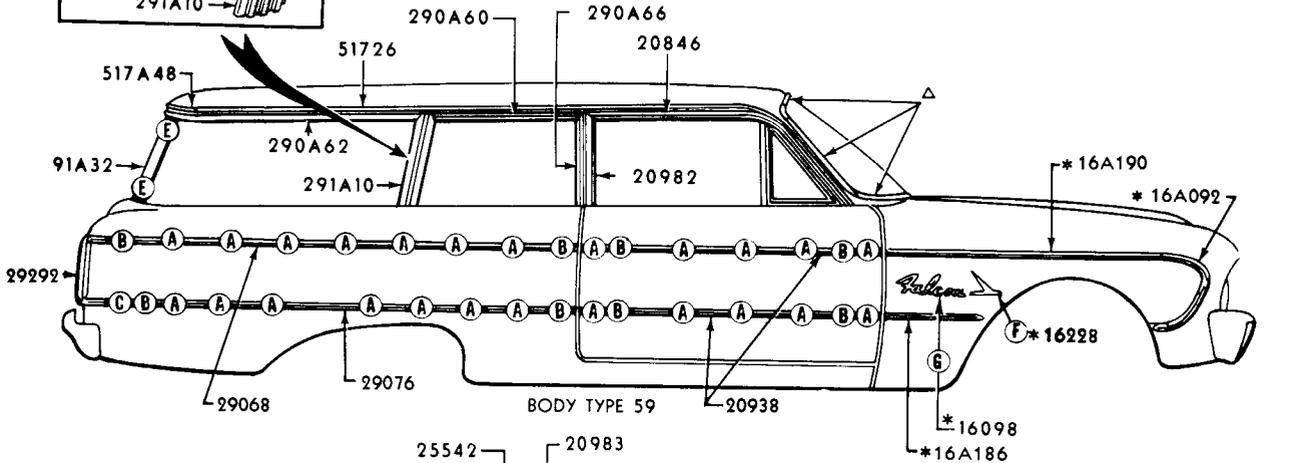
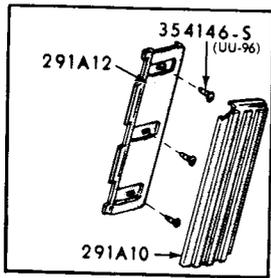

* REFER TO GROUP IN CHASSIS SECTION
 △ REFER TO BODY ILLUSTRATION SECTION 030
 ◇ REFER TO BODY ILLUSTRATION SECTION 400

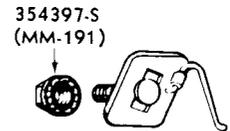
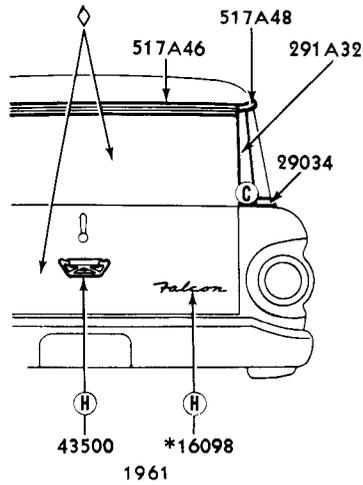
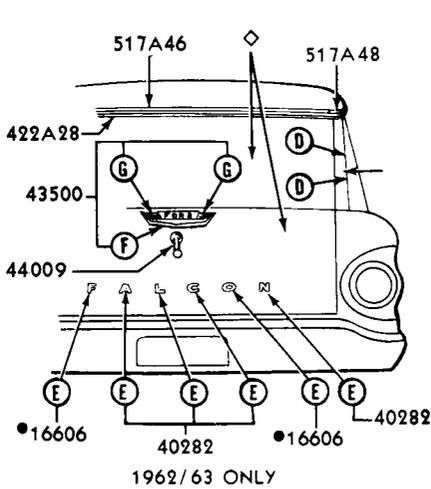
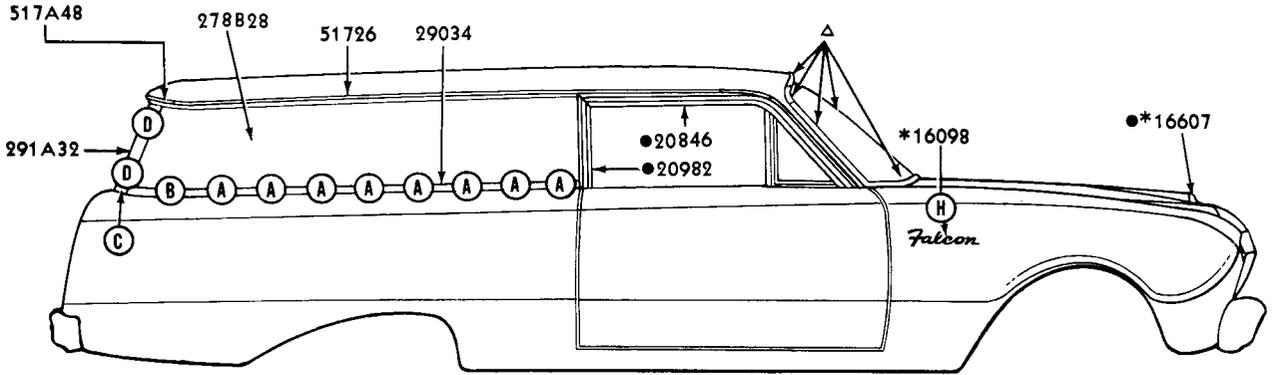

COAZ-6442527-B

A

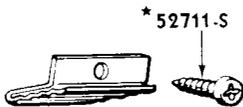

C1AB-6242413-A

B



*52711-S

C



359606-S
(MM-291-A)

D



375890-S
(MM-222-A)

E



353577-S
(MM-222)

F



373503-S
(MM-285-A)

G



*371583-S

H

* REFER TO GROUP IN CHASSIS SECTION
 ▲ REFER TO BODY ILLUSTRATION SECTION 030
 ◇ REFER TO BODY ILLUSTRATION SECTION 400
 ●1962/63 ONLY

**X EXTERIOR Moulding
ILLUSTRATION SECTION**

FORD CAR PARTS

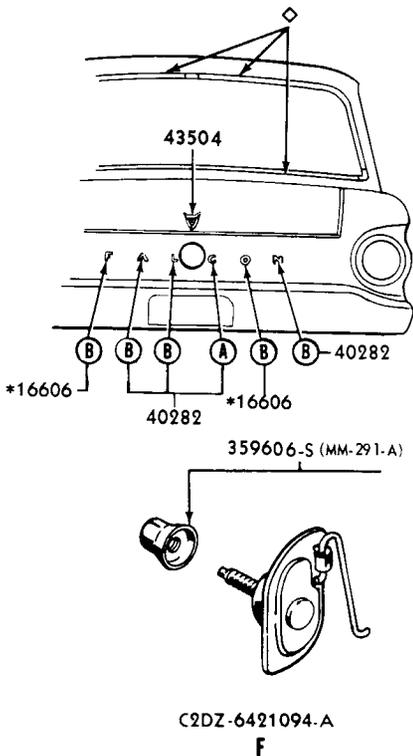
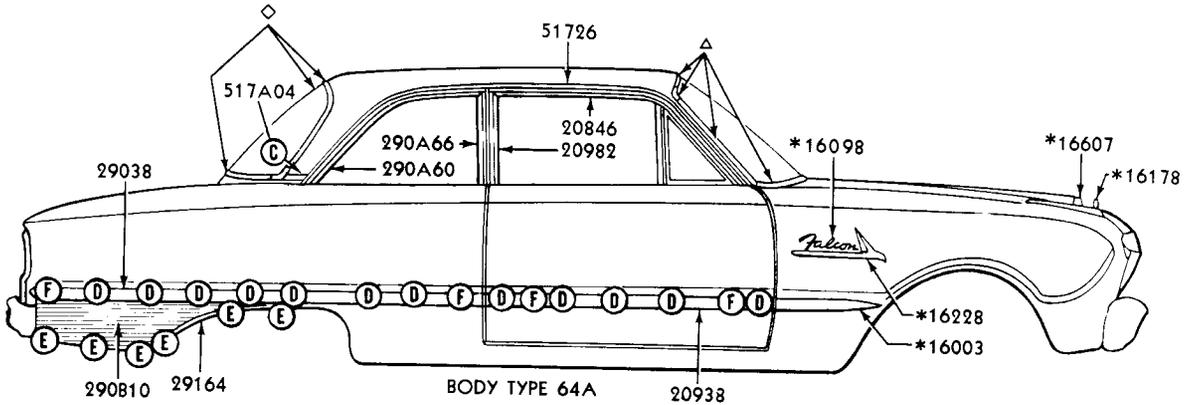
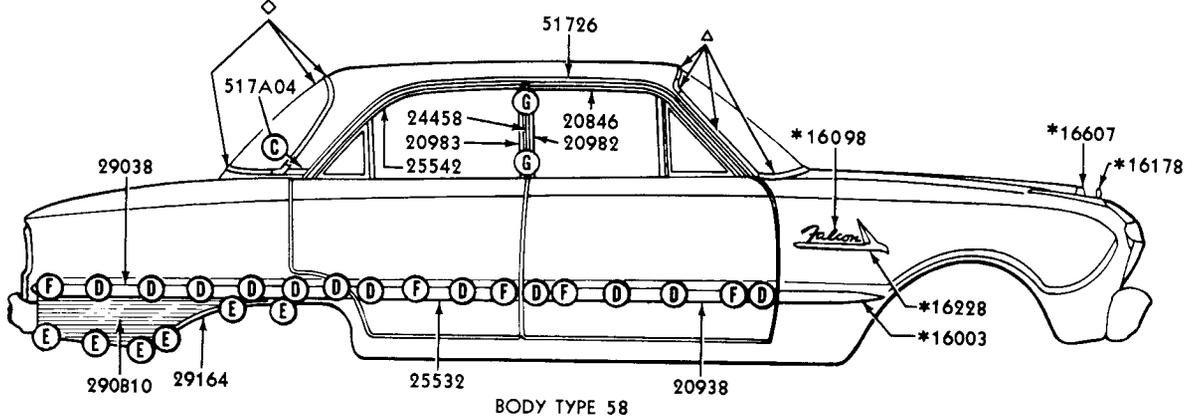

375890-S (MM-222-A)

A



374046-S (MM-116)

B



*C2DB-64517A60-A

C

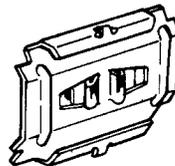

C2DZ-6429120-A

D



376378-S (UU-97)

E



376374-S (BB-99)

G

* REFER TO GROUP IN CHASSIS SECTION
 Δ REFER TO BODY ILLUSTRATION SECTION 030
 ◇ REFER TO BODY ILLUSTRATION SECTION 400

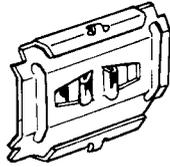
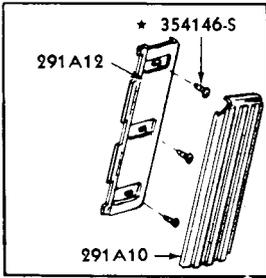

C2DZ-6429120-A

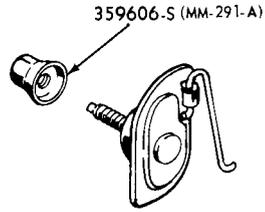

C2DZ-6421094-A

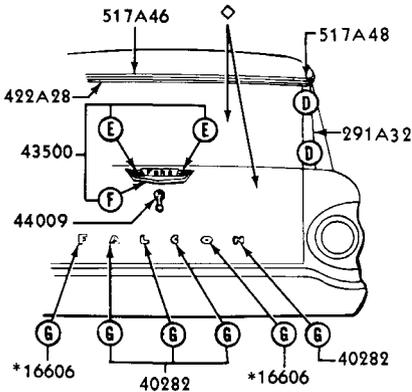
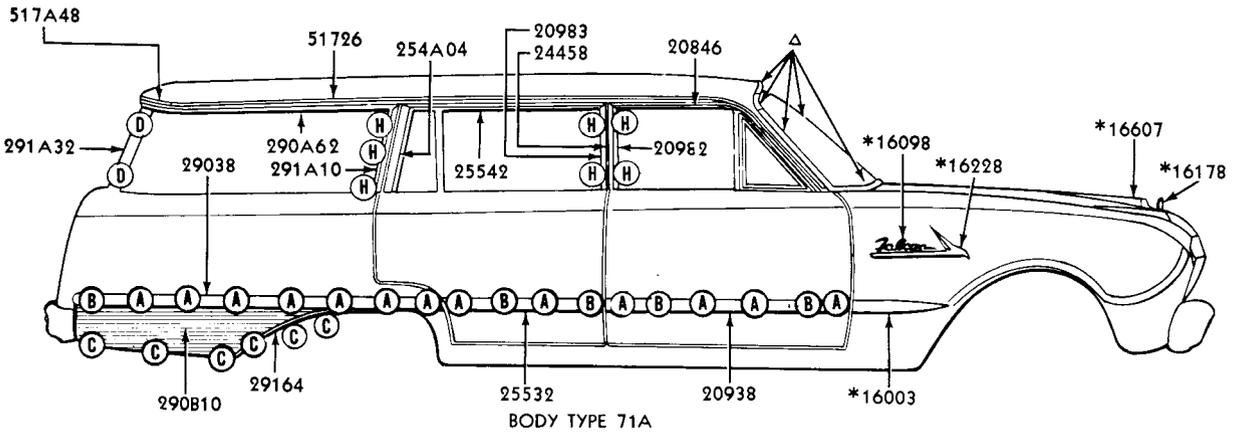
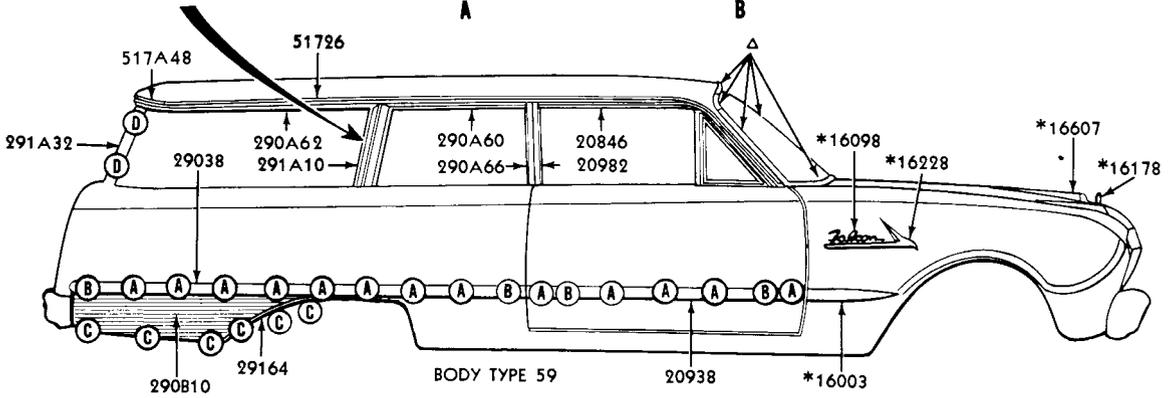

376378-S (UU-97)

C



359606-S (MM-291-A)

D



373504-S (MM-285-B)

E



353577-S (MM-222)

F



375890-S (MM-222-A)

G



376374-S (BB-99)

H

- * REFER TO GROUP IN CHASSIS SECTION
- △ REFER TO BODY ILLUSTRATION SECTION 030
- ◇ REFER TO BODY ILLUSTRATION SECTION 400

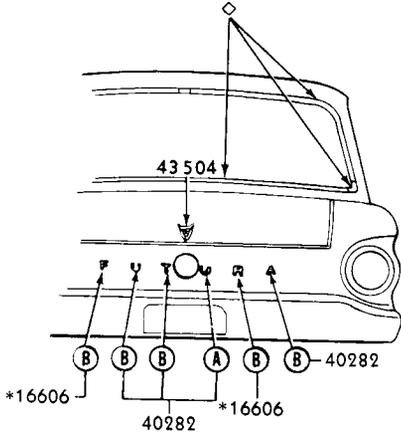
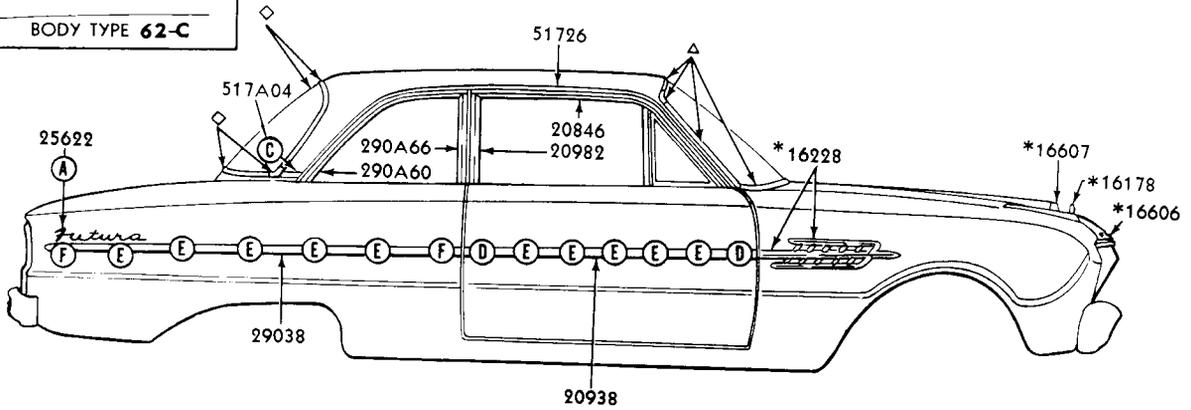
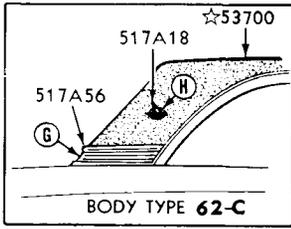

375890-S (MM-222-A)
A



374046-S (MM-116)
B



*C2DB-64517A60-A
C



51764-S (U-366)
D

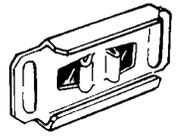

C2DZ-6420842-A
E

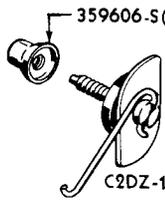

359606-S (MM-291-A)
C2DZ-16A076-C
F



375526-S (MM-295-H)
G



373503-S (MM-285-A)
H

* REFER TO GROUP IN CHASSIS SECTION 160
 △ REFER TO BODY ILLUSTRATION SECTION 030
 ◇ REFER TO BODY ILLUSTRATION SECTION 400
 ☆ REFER TO SOFT TRIM SECTION

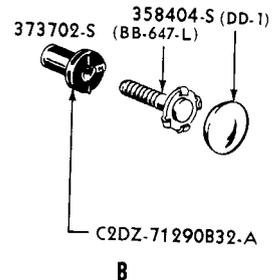
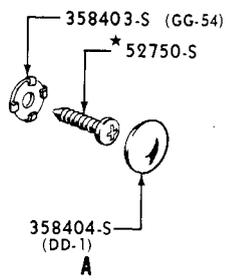
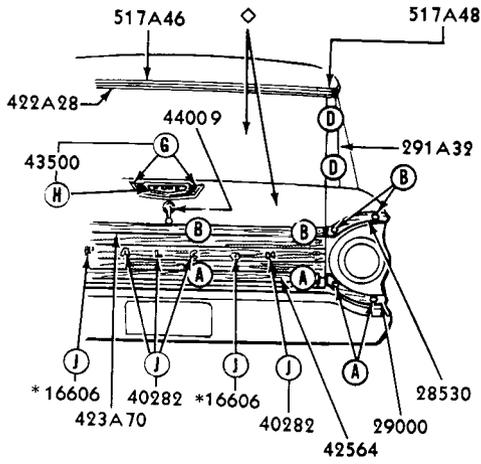
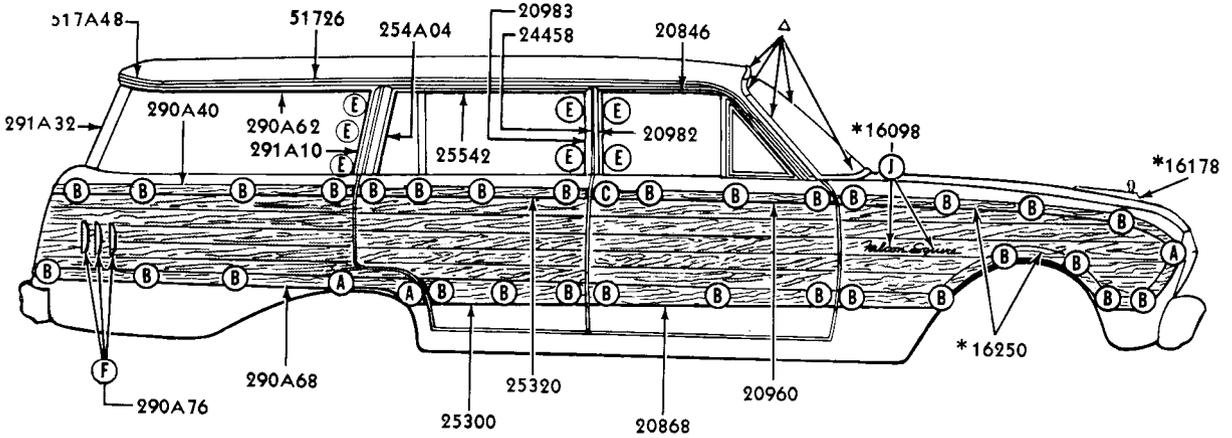

350754-S (UU-86)

C



359606-S (MM-291-A)

D



376374-S (BB-99)

E



373503-S

F



373504-S (MM-285-B)

G



353577-S (MM-222)

H



375890-S (MM-222-A)

J

* REFER TO GROUP IN CHASSIS SECTION
 Δ REFER TO BODY ILLUSTRATION SECTION 030
 ◇ REFER TO BODY ILLUSTRATION SECTION 400

WALNUT TRANSFER C2DZ-7120748-A

P-3752

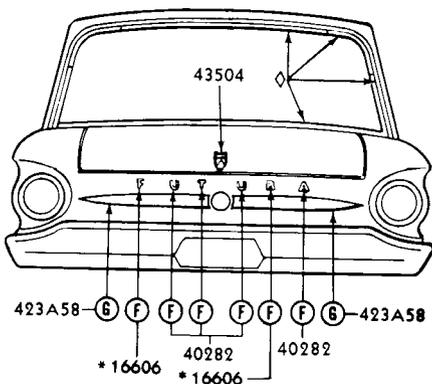
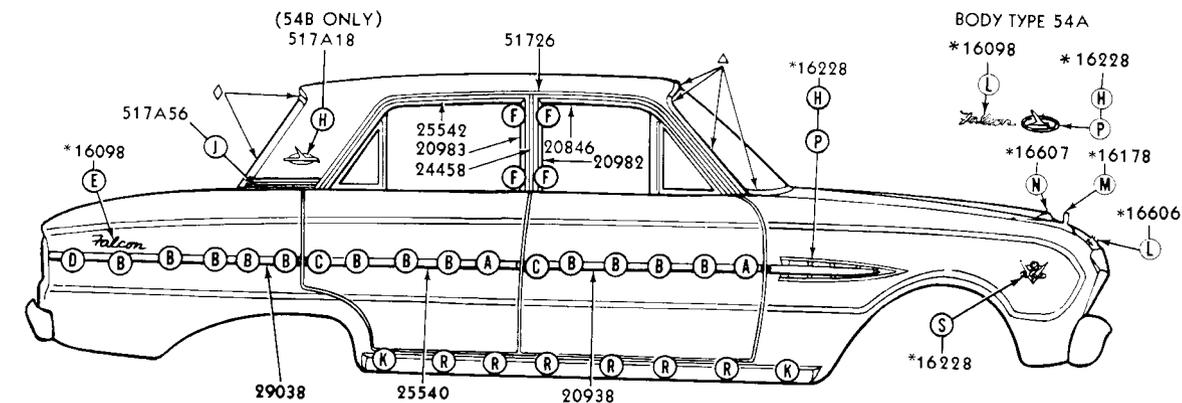

BODY TYPE 54B

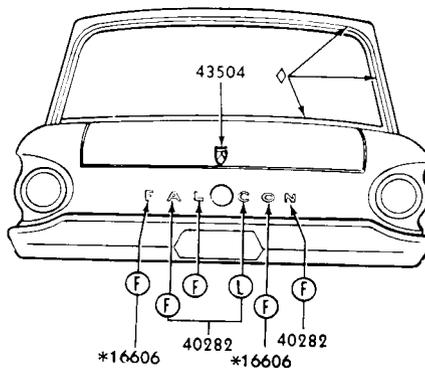

BODY TYPE 54A
359606-S (MM-291-A)

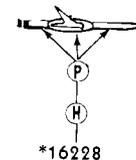

BODY TYPE 54A

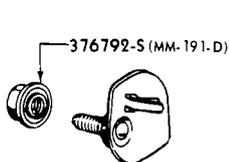

C3DZ-6221094-A

A

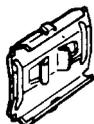

C2AZ-6229120-A

B



350002-S
(BB-529)

C

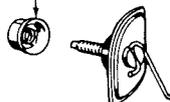

COAZ-6421094-C

D



*376718-S

E



374046-S (MM-116)

F



374073-S
(MM-118)

G



373503-S
(MM-285-A)

H



375526-S
(MM-295-H)

J



*C2YB-62102A78-A

K



375890-S (MM-222-A)

L



354397-S
(MM-291)

M



33795-S (M-49)
34805-S (X-62)

N



370548-S
(MM-295)

P



C2YY-6210182-A

R



*376559-S

S

▲ REFER TO BODY ILLUSTRATION SECTION 030
◇ REFER TO BODY ILLUSTRATION SECTION 400
*REFER TO GROUP IN CHASSIS SECTION

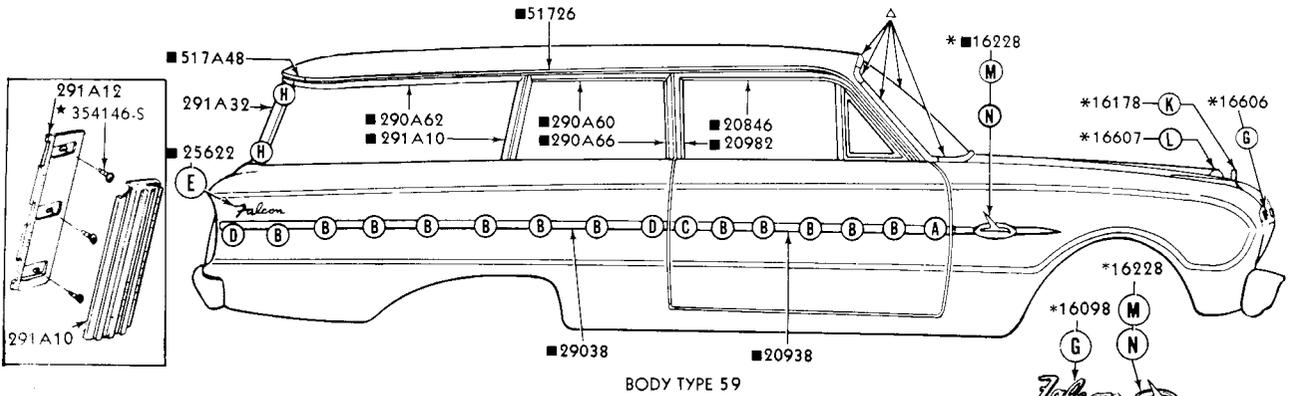

BODY TYPE 59

Falcon
59A 71A

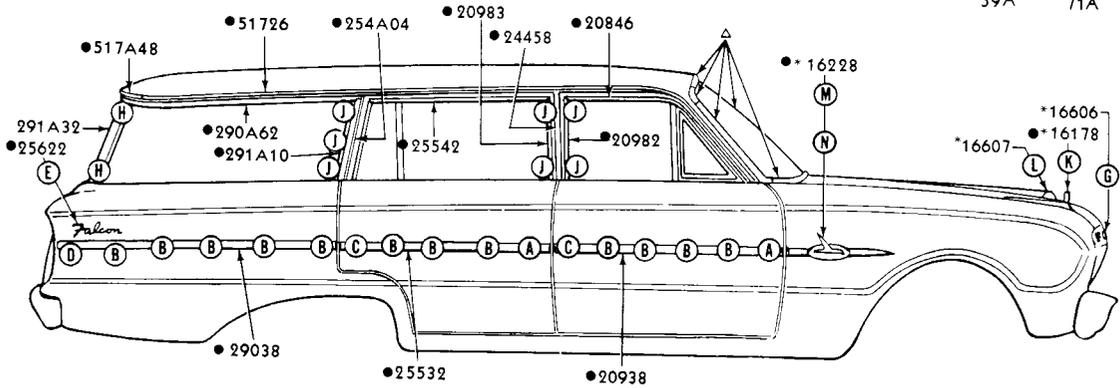

BODY TYPE 71A,B

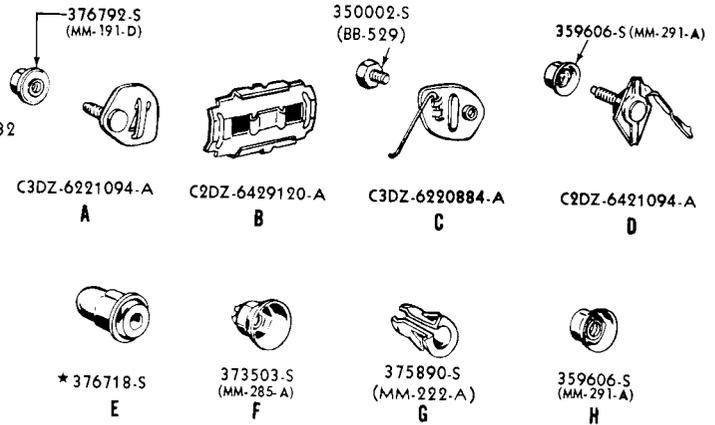
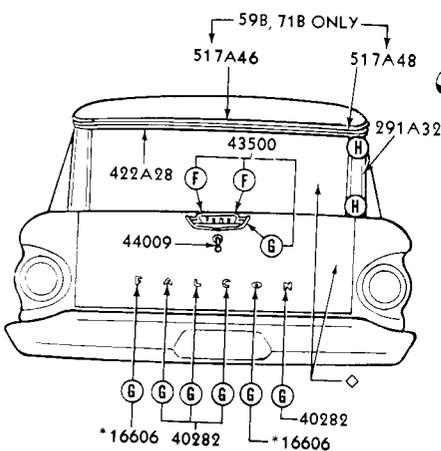

△ REFER TO BODY ILLUSTRATION SECTION 030
 ◇ REFER TO BODY ILLUSTRATION SECTION 400
 *REFER TO GROUP IN CHASSIS SECTION

■ BODY TYPE 59B
 ● BODY TYPE 71B

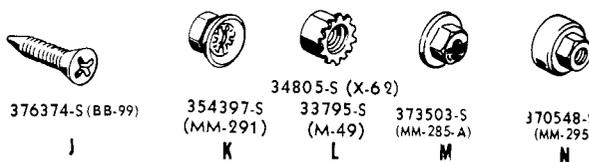

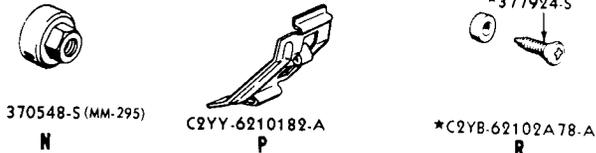
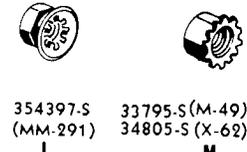
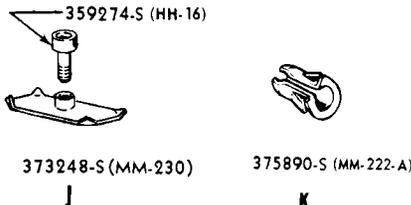
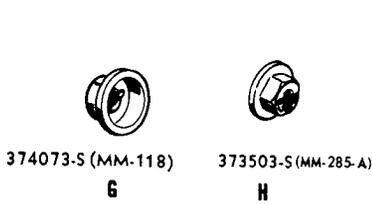
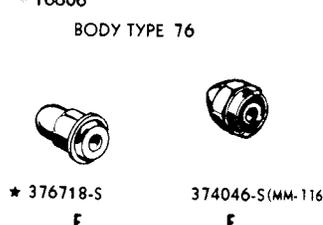
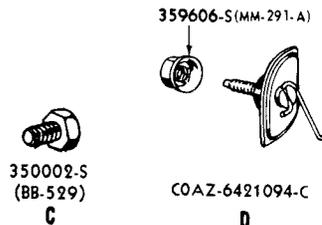
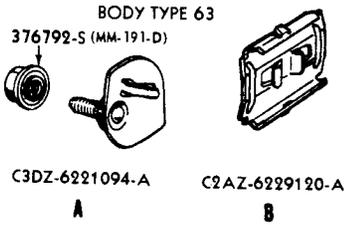
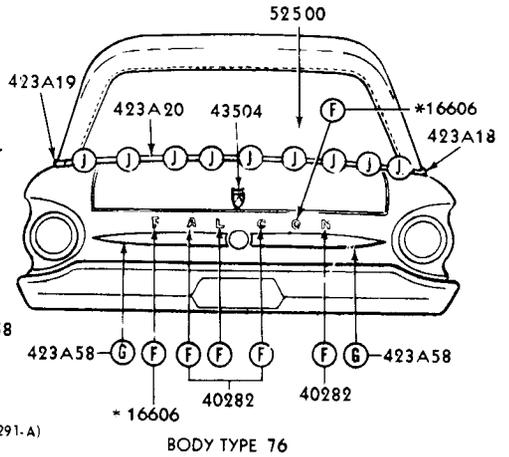
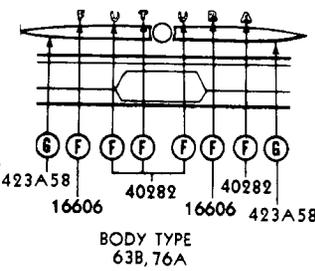
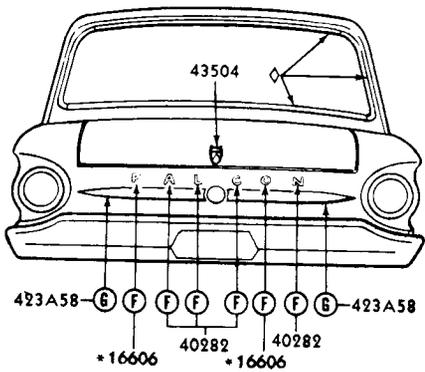
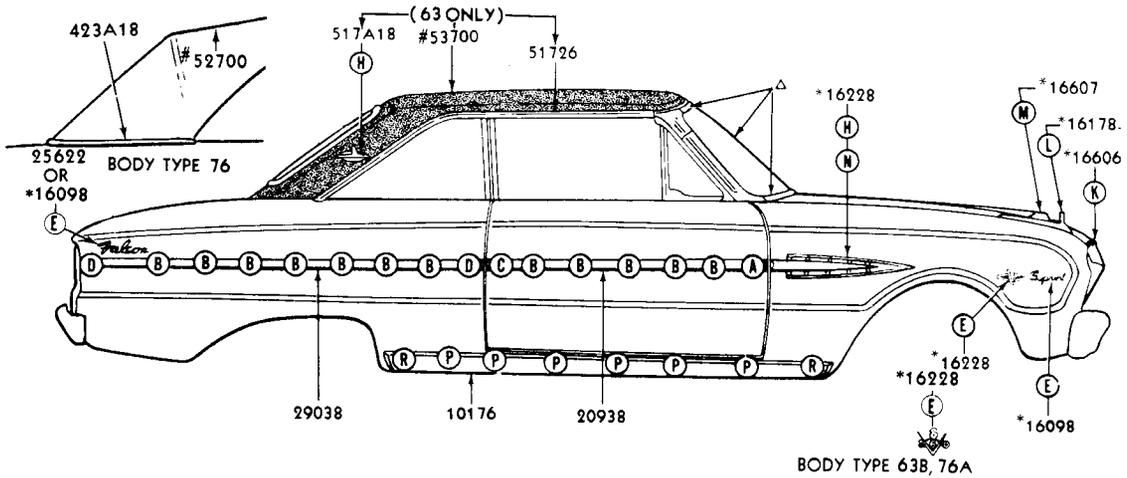

△ REFER TO BODY ILLUSTRATION SECTION 030
 ◊ REFER TO BODY ILLUSTRATION SECTION 400
 *REFER TO GROUP IN CHASSIS SECTION
 # REFER TO SOFT TRIM SECTION

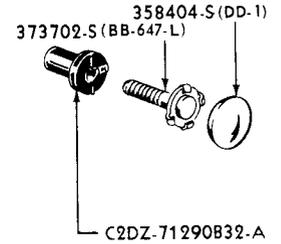
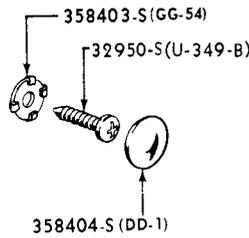
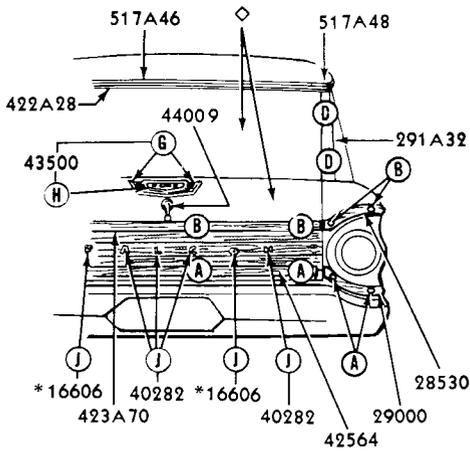
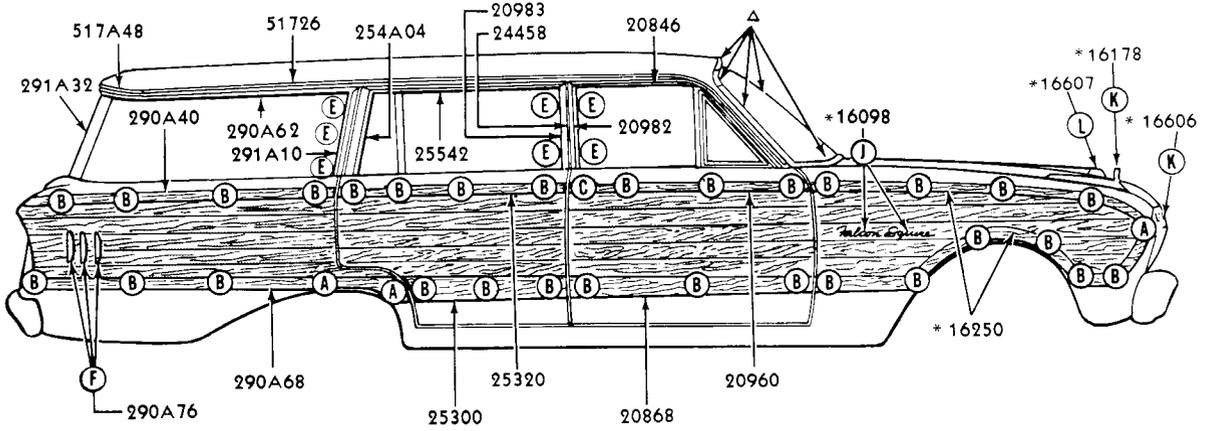

350754-S
(UU-86)
C



359606-S
(MM-291-A)
D



376374-S
(BB-99)
E



373503-S
(MM-285-A)
F



*371107-S
G



353577-S
(MM-222)
H



375890-S
(MM-222-A)
J



354397-S
(MM-291)
K



33795-S (M-49)
34805-S (X-62)
L

△ REFER TO BODY ILLUSTRATION SECTION 030
◇ REFER TO BODY ILLUSTRATION SECTION 400
*REFER TO GROUP IN CHASSIS SECTION

WALNUT TRANSFER C2DZ-7120748-A

P.3985

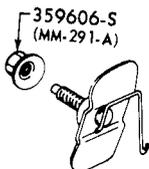
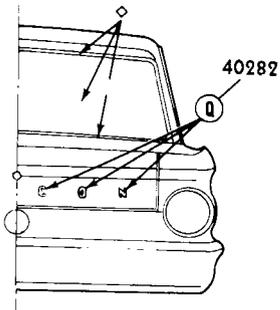
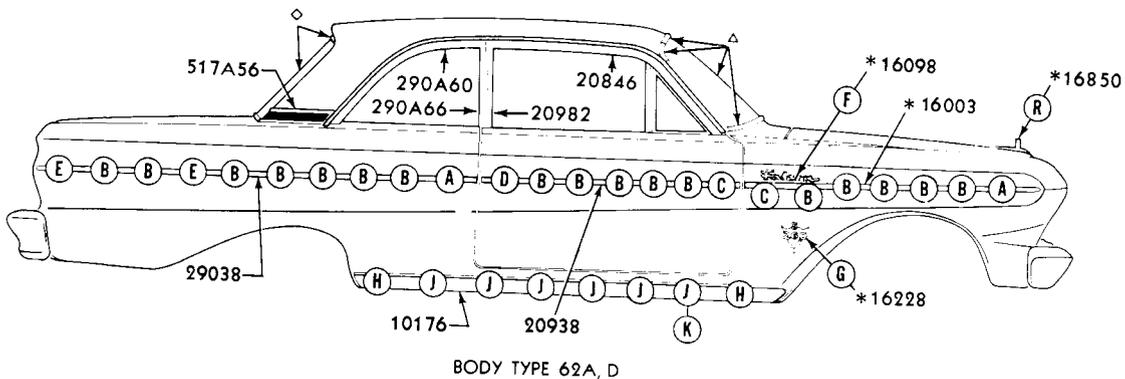
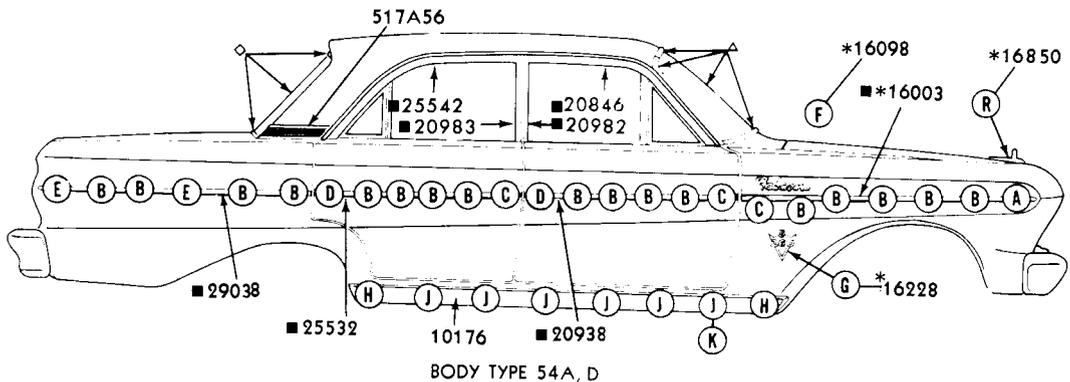

C4DZ-6221094-A
A



C4DZ-6221094-B
B

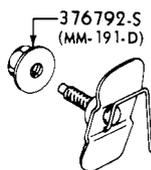

C4DZ-6221094-A
C

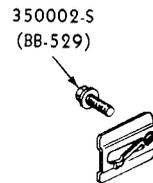

C4DZ-6221094-D
D



C4DZ-6221094-A
E



375890-S
 (MM-290-A)
F



375480-S
 (MM-222-E)
G



*C2YB-62102A78-A
H



C2YY-6210182-A
J



52376-S
 (U-296)
K



378362-S
 (MM-228)
Q



45243-S
 (M-178)
R

△ REFER TO BODY ILLUSTRATION SECTION 03C

◇ REFER TO BODY ILLUSTRATION SECTION 400

* REFER TO GROUP IN CHASSIS SECTION

■ BODY TYPE 54D

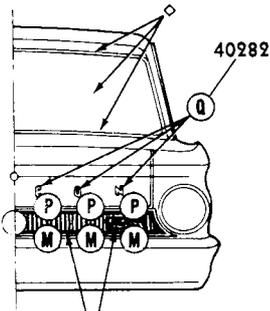
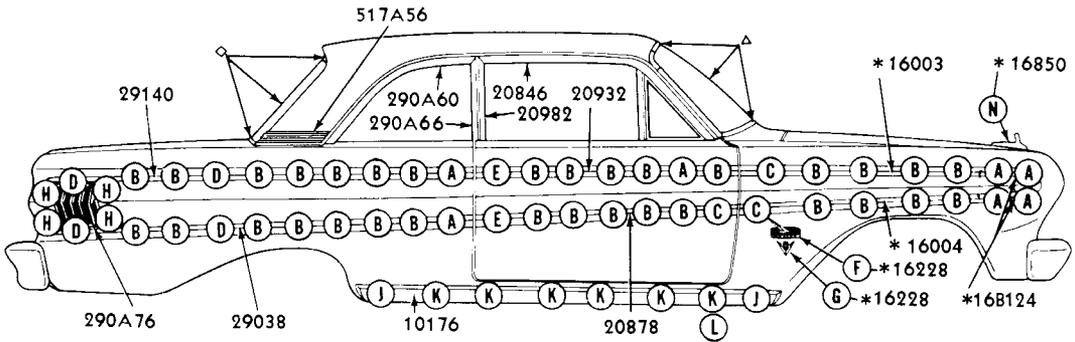
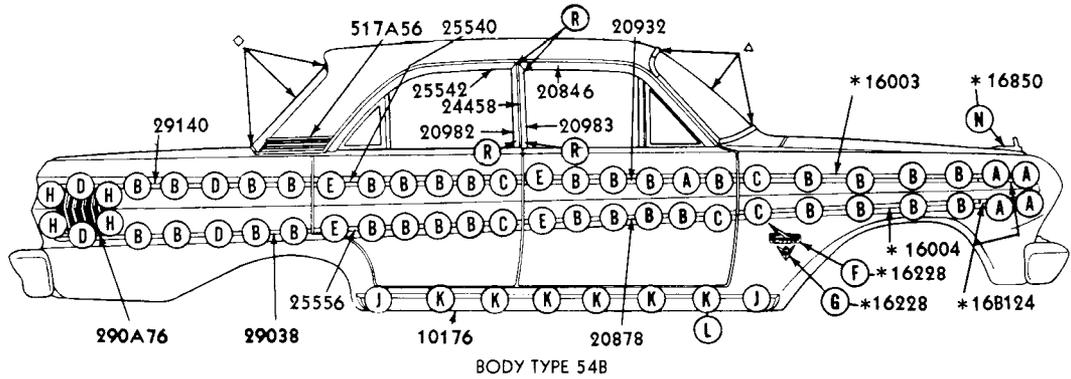

423A42

359606-S
(MM-291-A)

C3OZ-6220884-A

A

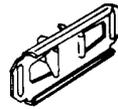

ALTERNATES

C4DZ-16A076-A

B

376792-S
(MM-191-D)

C3OZ-6220884-A

C

375690-S
(MM-290-D)



C3OZ-6220884-A

D

350002-S
(BB-529)



C2SZ-6320880-B

E



375890-S
(MM-290-A)

F



375480-S
(MM-222-E)

G



* 376031-S

H



* C2YB-62102A78-A

J



C2YY-6210182-A

K



52376-S (U-296)

L

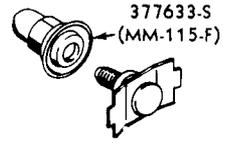

377633-S
(MM-115-F)

C4DZ-62423A64-A

M



45243-S (M-178)

N



376378-S (UU-97)

P



378362-S
(MM-228)

Q



* 376734-S

R

△ REFER TO BODY ILLUSTRATION SECTION 030

◇ REFER TO BODY ILLUSTRATION SECTION 400

* REFER TO GROUP IN CHASSIS SECTION

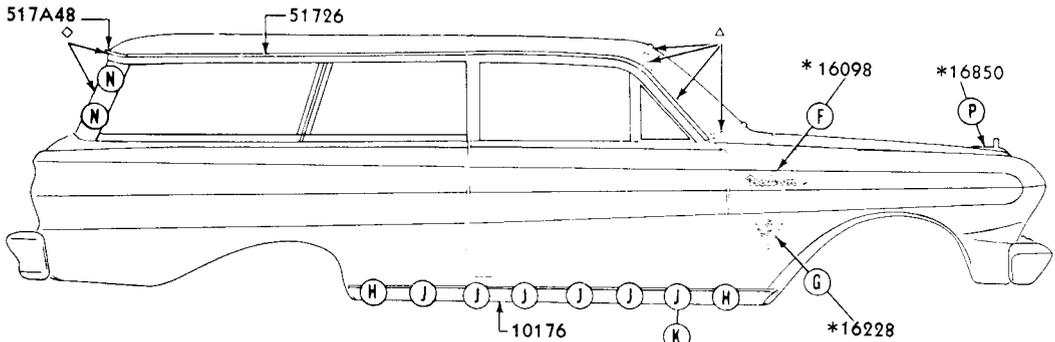

BODY TYPE 59

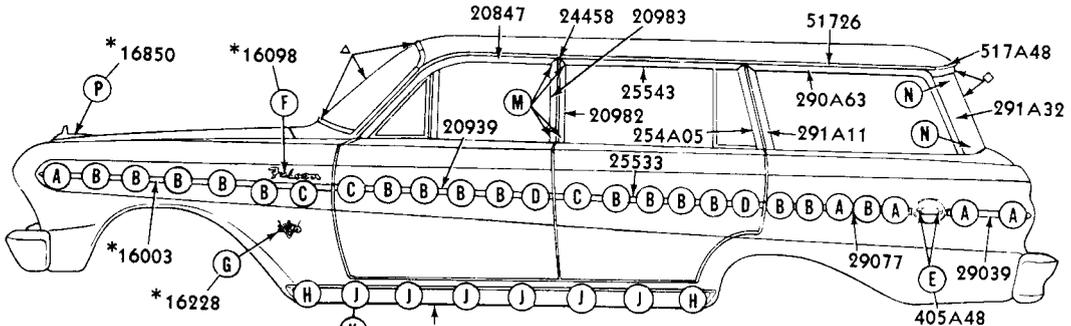

BODY TYPE 71A, B

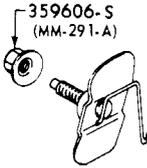
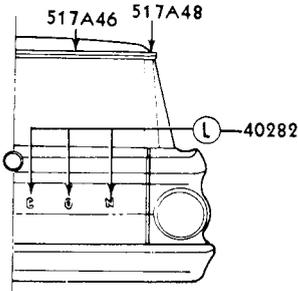

C4OZ-6221094-A
A

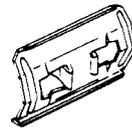

C4OZ-6221094-B
B

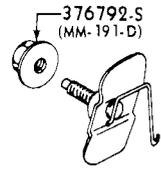

C4OZ-6221094-A
C

52376-S (U-296)

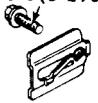

C4DZ-6221094-D
D



40917-S (U-257)
E



375890-S (MM-222-A)
F



375480-S (MM-222-E)
G



*377924-S
*C2YB-62102A78-A
H

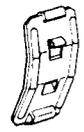

C2YY-6210182-A
J



376374-S (BB-99)
M



359606-S (MM-291-A)
N



45243-S (M-178)
P



373715-S (MM-172)
K



378362-S (MM-228)
L

- △ REFER TO BODY ILLUSTRATION 030
- ◇ REFER TO BODY ILLUSTRATION 400
- * REFER TO GROUP IN CHASSIS SECTION

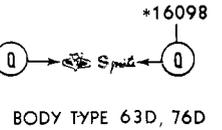
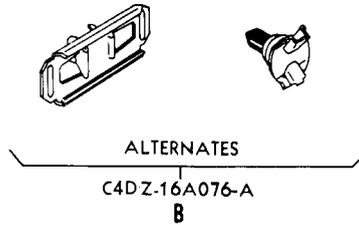
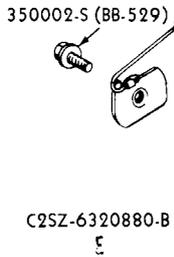
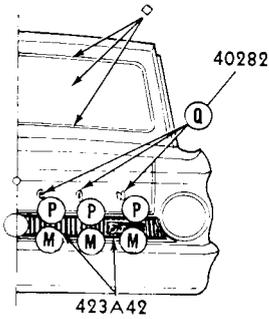
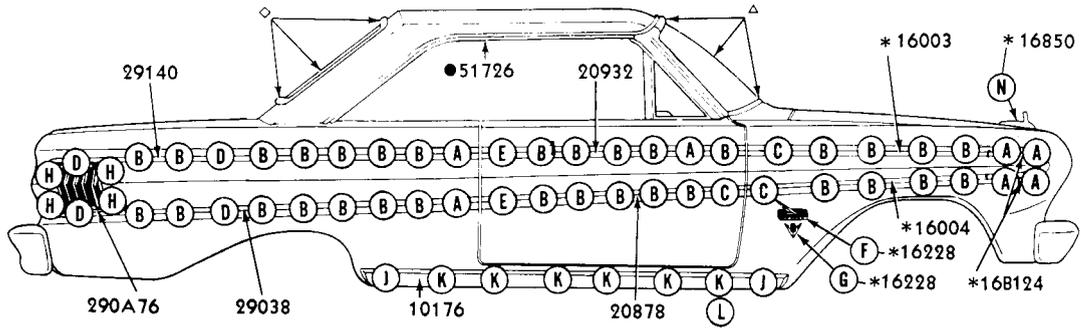

BODY TYPE 63D, 76D

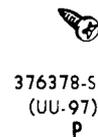
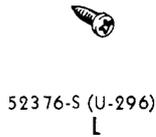
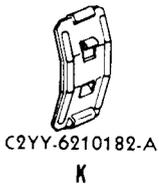
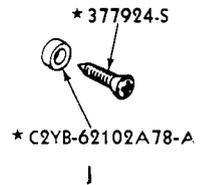
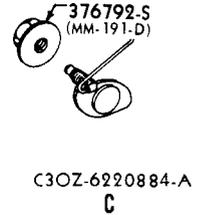

- BODY TYPE 63
- △ REFER TO BODY ILLUSTRATION SECTION 030
- ◇ REFER TO BODY ILLUSTRATION SECTION 400
- * REFER TO GROUP IN CHASSIS SECTION

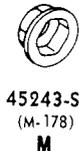
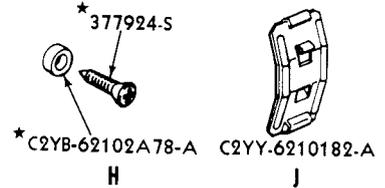
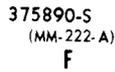
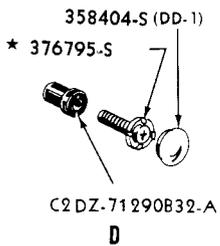
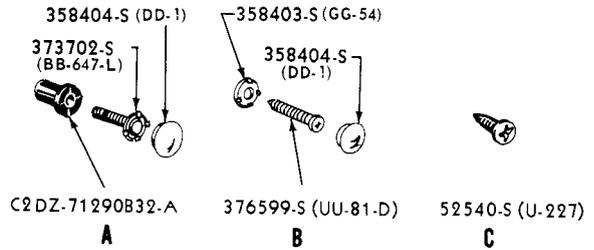
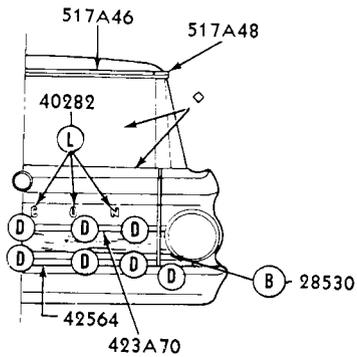
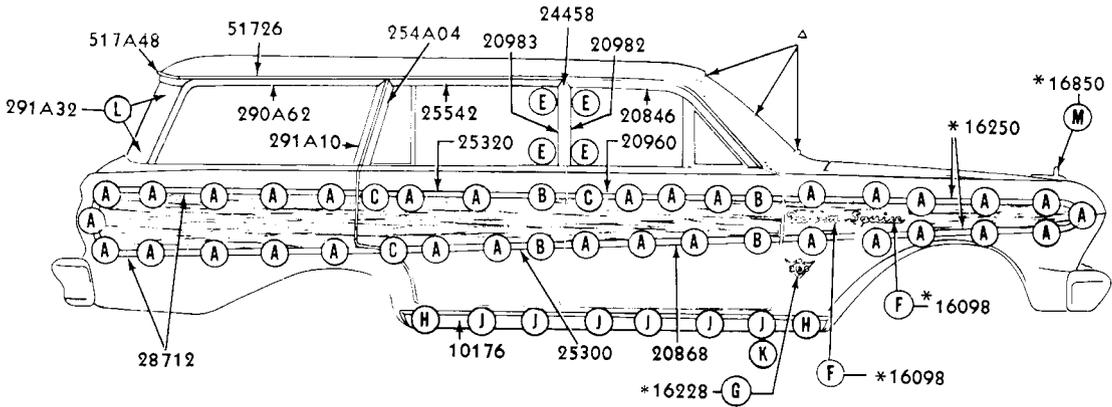

WALNUT GRAIN TRANSFER REFER TO BODY GROUP 20748

△ REFER TO BODY ILLUSTRATION 030

◇ REFER TO BODY ILLUSTRATION 400

* REFER TO GROUP IN CHASSIS SECTION

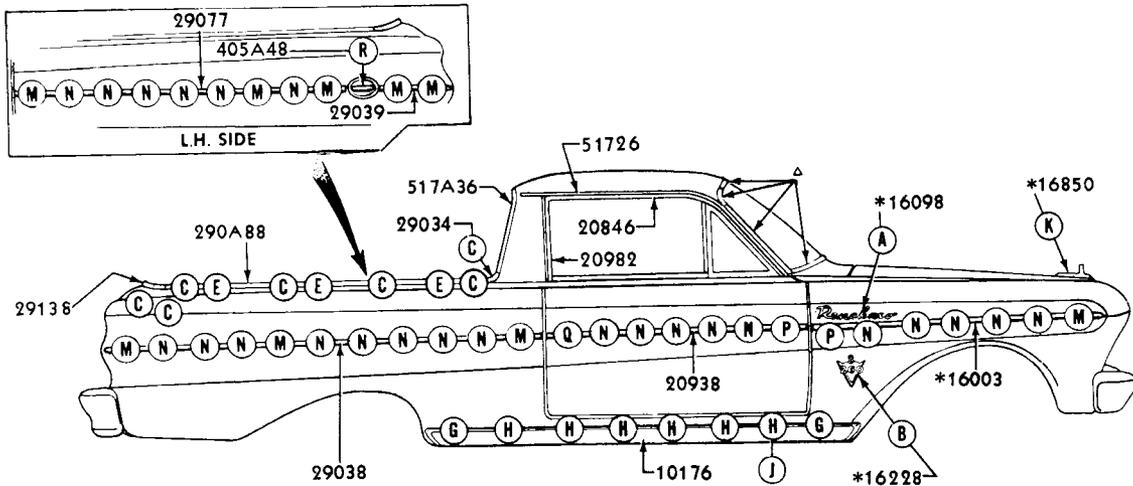

- 375890-S
(MM-222-A)
A
- 375480-S
(MM-222-E)
B
- *372666-S
C
- CODB-66517A68-A
D
- CODB-66290B16-A
E
- *376366-S
F
- *377924-S
*C2YB-62102A78-A
G

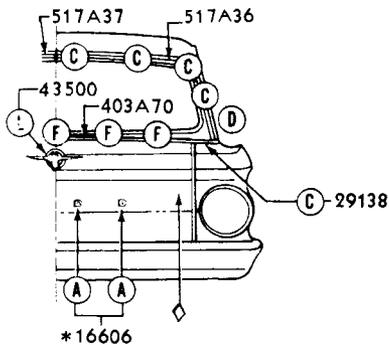

- C2YY-6210182-A
H
- 52376-S (U-296)
J
- 45243-S
(M-178)
K
- 371882-S (MM-287)
L

- C4DZ-6221094-A
M
- C4DZ-6221094-B
N
- C4DZ-6221094-A
P
- C4DZ-6221094-D
Q
- 40917-S (U-257)
R

△ REFER TO BODY ILLUSTRATION SECTION 030
◇ REFER TO BODY ILLUSTRATION SECTION 400
* REFER TO GROUP IN CHASSIS SECTION

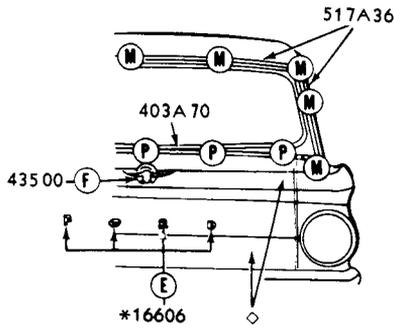
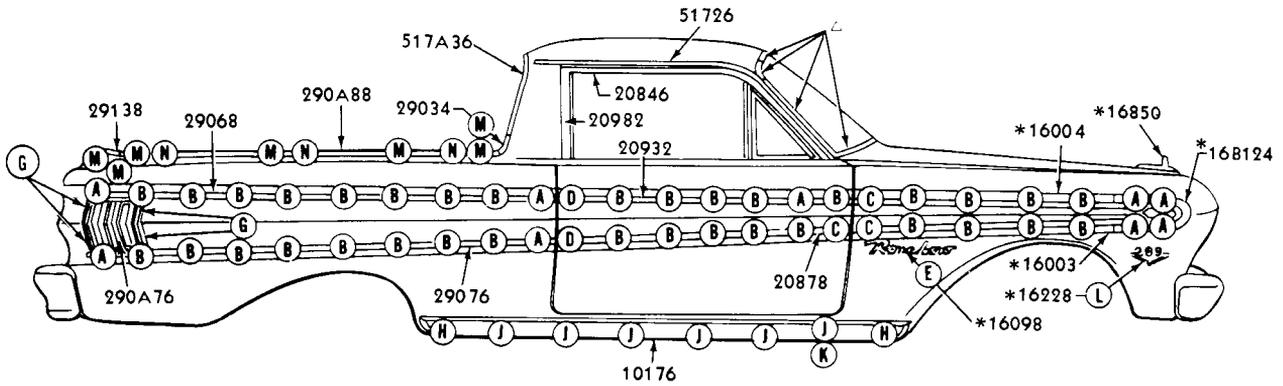

C30Z-6220884-A

A

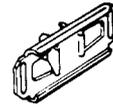

ALTERNATES
C4DZ-16A076-A

B



C30Z-6220884-A

C

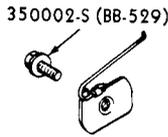

C2SZ-6320880-B

D



375890-S
(MM-222-A)

E

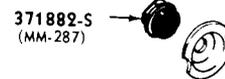

C4DZ-6642622-A

F



354397-S
(MM-291)

G



*377924-S
*C2YB-62102A78-A

H

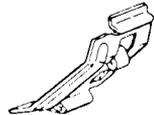

C2YY-6210182-A

J



350075-S
(UU-88)

K



375480-S
(MM-222-E)

L



376290-S
(UU-56-D)

M



CODB-66290B16-A

N



376290-S
(UU-56-D)

P

△ REFER TO BODY ILLUSTRATION SECTION 030
 ◇ REFER TO BODY ILLUSTRATION SECTION 400
 * REFER TO GROUP IN CHASSIS SECTION
 1964/ FALCON - BODY TYPE 66G, H

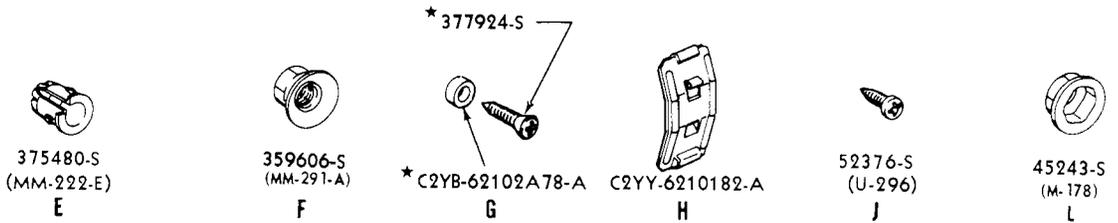
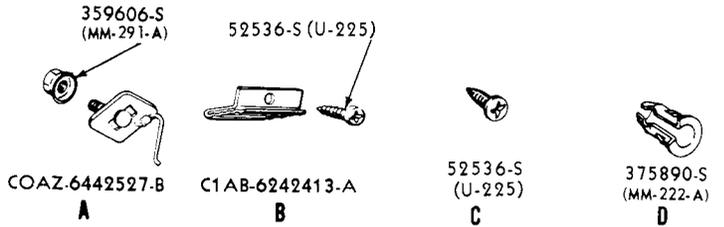
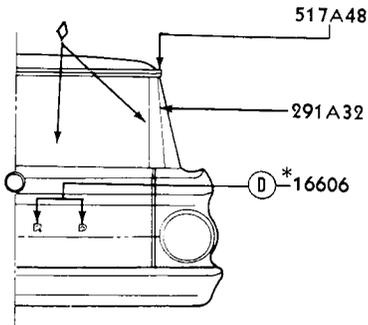
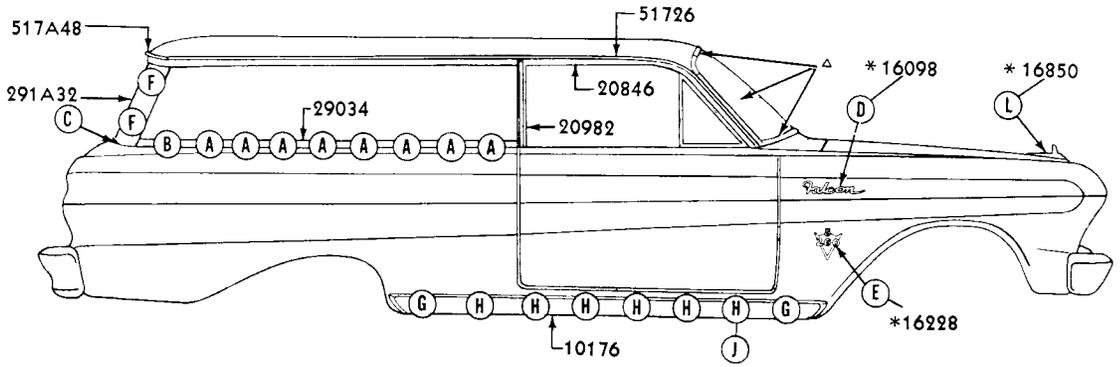

△ REFER TO BODY ILLUSTRATION SECTION 030

◇ REFER TO BODY ILLUSTRATION SECTION 400

* REFER TO GROUP IN CHASSIS SECTION