

INDEX

INCLUDED IN THIS INDEX ARE THE FOLLOWING MAJOR GROUPS IN THE ORDER SHOWN BELOW:

BACK WINDOW-TAIL & LIFT GATE

LIFT GATE & LUGGAGE COMPARTMENT DOOR HANDLE

ROOF

YEAR	TITLE	ILLUS. NO.	SECTION	PAGE
BACK WINDOW - TAIL and LIFT GATE				
FAIRLANE				
1962/	Back Window and Related Parts-Body Type 54, 62-Typical	P-3760	400	703
1963	Back Window and Related Parts-Body Type 65	P-4037	400	705
1963/	Tail Gate Weatherstrip and Related Parts-Body Type 71	P-4040	400	697
1963	Tail Gate Window and Related Parts-Body Type 71-Typical	P-4041	400	698
FALCON				
1960/62	Back Window and Related Parts-Body Types 58, 64	P-3017	400	699
1962	Back Window and Related Parts-Body Type 62C	P-3815	400	705
1963/	Back Window and Related Parts-Body Type 54, 62-Typical	P-3817	400	705
1963/	Back Window and Related Parts-Body Type 63-Typical	P-3982	400	707
1960/63	Tail Gate Weatherstrip and Related Parts-Before 5/1/63-Typical	P-3161	400	688
1963/	Tail Gate Weatherstrip and Related Parts-From 5/1/63-Typical	P-4151	400	689
1960/	Tail Gate and Related Parts-Typical	P-3202	400	691
1960/	Tail Gate Window and Related Parts-Typical	P-3199	400	690
FORD				
1960	Back Window and Related Parts-Body Types 54, 62, 75A	P-3016	400	699
1960	Back Window and Related Parts-Body Types 58, 64	P-3015	400	700
1960	Tail and Lift Gate and Related Parts-Body Types 59, 71	P-3020	400	687
1960	Back Window and Related Parts -Body Type 63	P-3018	400	700
1961	Tail Gate Weatherstrip and Trim Parts-Body Types 59, 71	P-3346	400	692
1961	Back Window and Related Parts-Body Types 58, 64	P-3348	400	703
1961	Back Window and Related Parts-Body Type 63	P-3349	400	702
1962	Tail Gate Weatherstrip and Trim Parts-Body Type 71	P-3779	400	694
1961/63	Back Window and Related Parts-Body Types 54, 62, 65, 75-Typical	P-3347	400	702
1963	Tail Gate Weatherstrip and Related Parts-Body Type 71	P-4039	400	695
1964	Back Window and Related Parts-Body Type 54	P-4347	400	708
1964	Back Window and Related Parts-Outside-Body Type 57	P-4348	400	709
1964	Back Window & Roof Side Moulding, Weatherstrip & Related Parts-Inside-Body Type 57	P-4356	400	709
1964	Back Window & Related Parts -Body Type 62	P-4392	400	708
1964	Tail Gate Weatherstrip and Related Parts-Body Type 71	P-4427	400	696
1963/64	Back Window & Body Side Inside Mouldings-Body Type 63-Typical	P-4089	400	707
1963/64	Back Window Outside Mouldings & Related Parts-Body Type 63	P-4088	400	706
1961/64	Tail Gate Window and Related Parts-Body Types 59, 71-Typical	P-3385	400	693
THUNDERBIRD				
1960	Back Window and Related Parts-Body Type 63A	P-2616	400	701
1961/63	Back Window and Related Parts-Body Type 63	P-3352	400	704
1964	Back Window and Related Parts-Outside-Body Type 63	P-4349	400	710
1964	Back Window and Related Parts-Inside-Body Type 63	P-4350	400	710
LIFT GATE and LUGGAGE COMPARTMENT DOOR HANDLE				
FAIRLANE				
1962/63	Luggage Compartment Door Latch and Related Parts -except Body Type 71	P-3761	430	716
1964/	Luggage Compartment Door Latch and Related Parts-except Body Type 71	P-4359	430	719
FALCON				
1960/61	Luggage Compartment Door Latch and Related Parts-Body Types 58, 64	P-3162	430	713
1962/63	Luggage Compartment Door Latch and Related Parts- except 59, 66, 71, 78	P-4043	430	717
1964/	Luggage Compartment Door Latch and Related Parts-Body Types 54, 62, 63, 76	P-4360	430	719

INDEX

YEAR	TITLE	ILLUS. NO.	SECTION	PAGE
LIFT GATE and LUGGAGE COMPARTMENT DOOR HANDLE - continued				
FORD				
1960	Luggage Compartment Door Latch and Related Parts-Body Types 58E, 64F, 64G	P-3081	430	711
1960	Luggage Compartment Door Latch and Related Parts-Body Types 58F, 64H	P-3208	430	712
1960	Luggage Compartment Door Latch and Related Parts-Body Types 58A, 64A	P-3036	430	711
1960	Luggage Compartment Door Latch, Moulding and Related Parts-Body Types 54, 62, 63, 75, 76	P-3037	430	713
1961	Luggage Compartment Door Latch and Related Parts-Body Types 54, 58, 63, 64, 65, 75, 76	P-3351	430	714
1962	Luggage Compartment Door Latch and Related Parts-Body Types 54, 62, 65, 75, 76	P-3791	430	716
1963	Luggage Compartment Door Latch and Related Parts-except Body Type 71	P-4042	430	717
1964	Luggage Compartment Door Latch and Related Parts-except Body Type 71	P-4358	430	718
THUNDERBIRD				
1960	Luggage Compartment Door Latch and Related Parts-Body Type 63	P-2619	430	712
1961/63	Luggage Compartment Door Ornament-Body Type 76	P-3354	430	715
1961/63	Luggage Compartment Door Latch and Related Parts-Body Type 63	P-3355	430	715
1964/	Luggage Compartment Door Latch and Related Parts-Body Type 63	P-4357	430	718
1964/	Luggage Compartment Door Weatherstrip and Related Parts-Body Type 76	P-4387	430	720
ROOF				
FAIRLANE				
1963/	Roof Ski Carrier	P-4050	500	735
FALCON				
1963/64	Roof Side Weatherstrips and Related Parts-Body Type 63	P-4091	500	722
1963/	Roof Ski Carrier	P-4050	500	735
1963/	Folding Top Parts-Less Trim-Body Type 76	P-4006	500	731
1963/64	Folding Top Trim Parts-Body Type 76	P-3155	500	730
1960/64	Folding Top Parts-Less Trim-Body Type 76	P-3039	500	725
FORD				
1960/63	Roof Side Weatherstrips and Related Parts-Typical	P-3038	500	721
1963/64	Roof Side Weatherstrip and Related Parts-Body Types 57, 63	P-3957	500	722
1960/64	Folding Top Parts-Less Trim-Body Type 76	P-3039	500	725
1960/64	Folding Top Trim Parts-Body Type 76	P-3155	500	730
1960/64	Roof Luggage Carrier-Typical	P-3227	500	734
1963/	Roof Ski Carrier	P-4050	500	735
THUNDERBIRD				
1960	Roof Side Rail Weatherstrip and Related Parts-Body Type 63	P-2622	500	721
1960	Folding Top Parts-Less Trim-Body Type 76	P-2663	500	726
1960	Sliding Roof Panel and Related Parts-Body Type 63	P-3164	500	724
1960	Folding Top and Deck Lid Hydraulic Lift and Related Parts-Body Type 76	P-3473	500	728
1961/63	Roof Side Rail Weatherstrip and Related Parts-Body Type 63	P-3386	500	723
1961/63	Folding Top and Deck Lid Hydraulic Lift and Related Parts-Body Type 76	P-3415	500	729
1961/63	Folding Top Parts-Less Trim-Body Type 76	P-3387	500	727
1964/	Roof Side Rail Weatherstrips and Related Parts-Body Type 63A, B	P-4354	500	723
1963/	Roof Ski Carrier	P-4050	500	735
1964/	Folding Top Parts-Less Trim-Body Type 76	P-4385	500	732
1964/	Folding Top & Deck Lid Hydraulic Lift and Related Parts-Body Type 76	P-4386	500	733
1960/	Folding Top Trim Parts-Body Type 76	P-3155	500	730

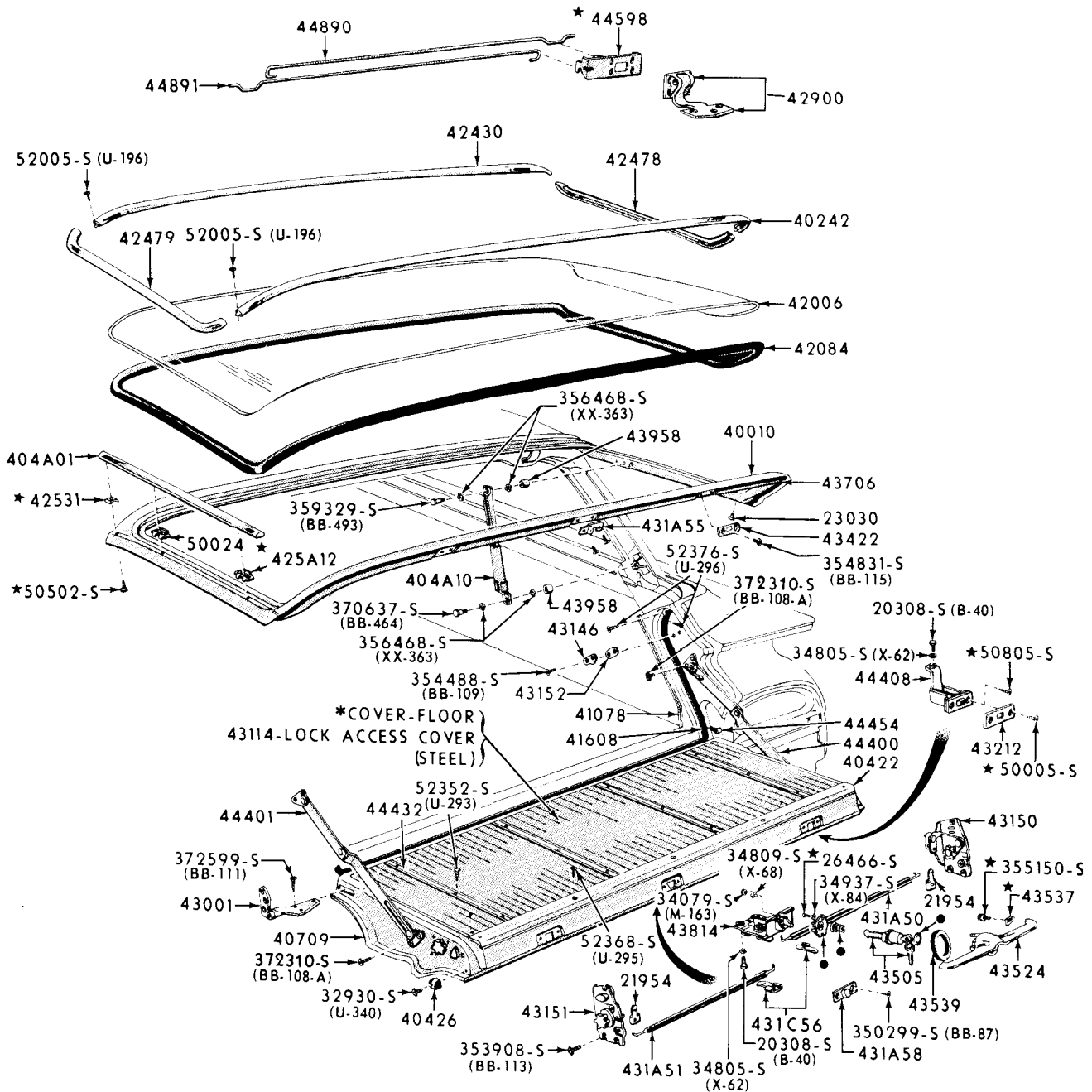

●SERVICED IN KIT 43442

* REFER TO GROUP 11488 IN SOFT TRIM SECTION OR BODY GROUP 40726

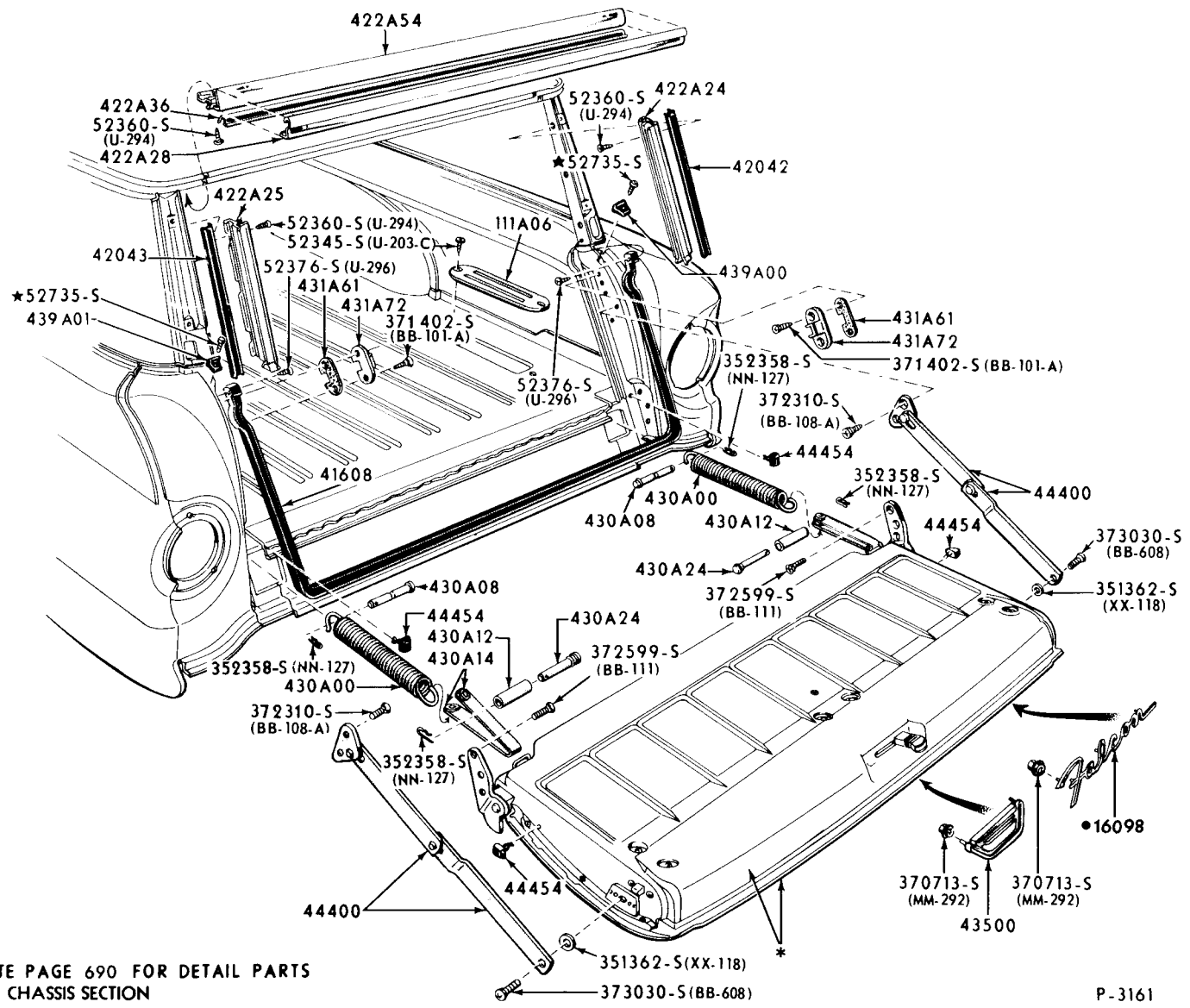

TAIL GATE WEATHERSTRIPS & RELATED PARTS
1960/63 FALCON-BODY TYPES 59, 71, 78 - "Before 5/1/69"

* REFER TO OPPOSITE PAGE 690 FOR DETAIL PARTS
 ● REFER TO GROUP IN CHASSIS SECTION

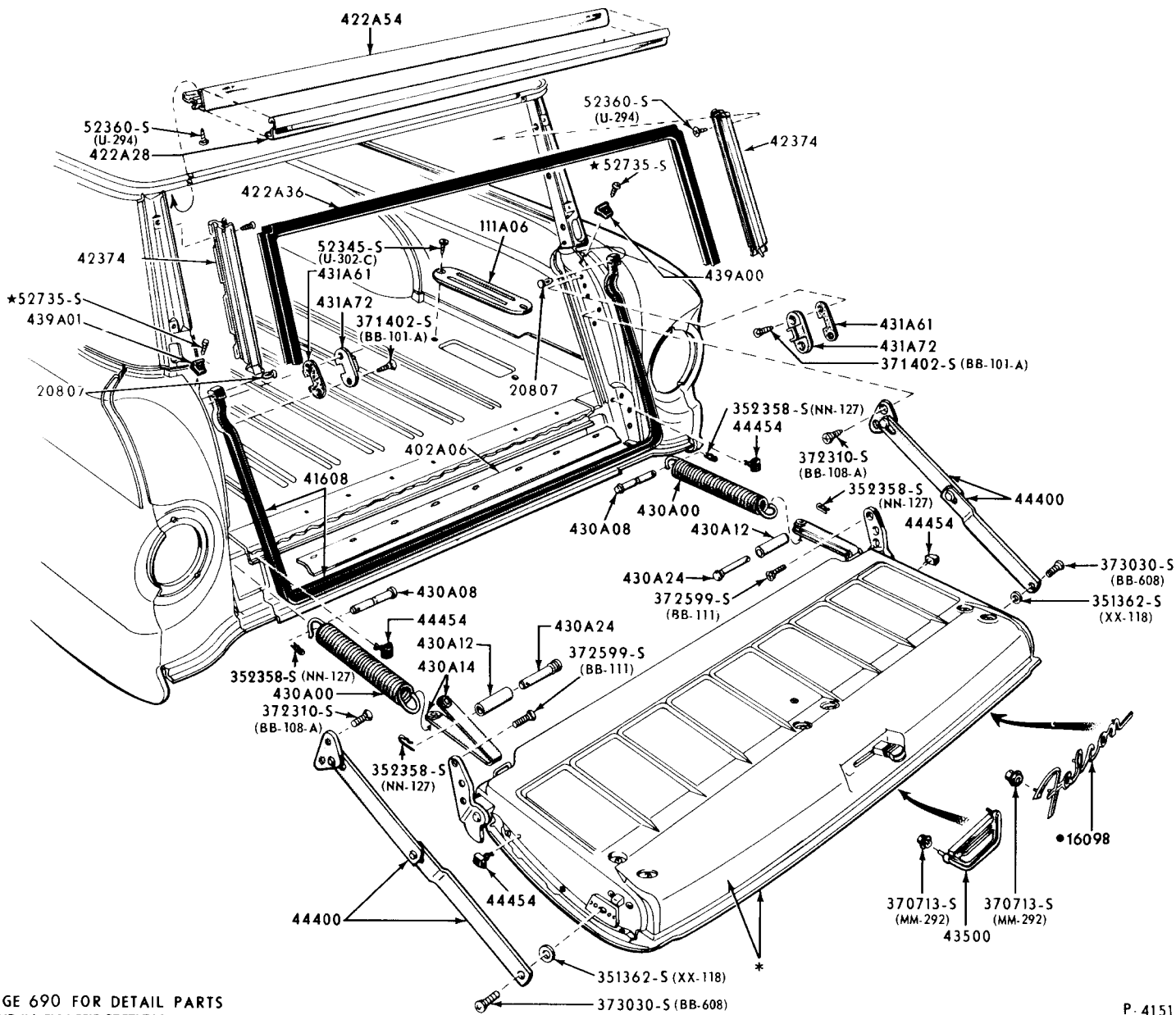

1963/ FALCON-BODY TYPES 59,71,78 - "From 5/1/63"

TAIL GATE WEATHERSTRIPS & RELATED PARTS

* REFER TO PAGE 690 FOR DETAIL PARTS
 • REFER TO GROUP IN CHASSIS SECTION

1960 / FALCON TYPICAL RANCH, STATION WAGON OR SEDAN DELIVERY TAIL GATE WINDOW & RELATED PARTS

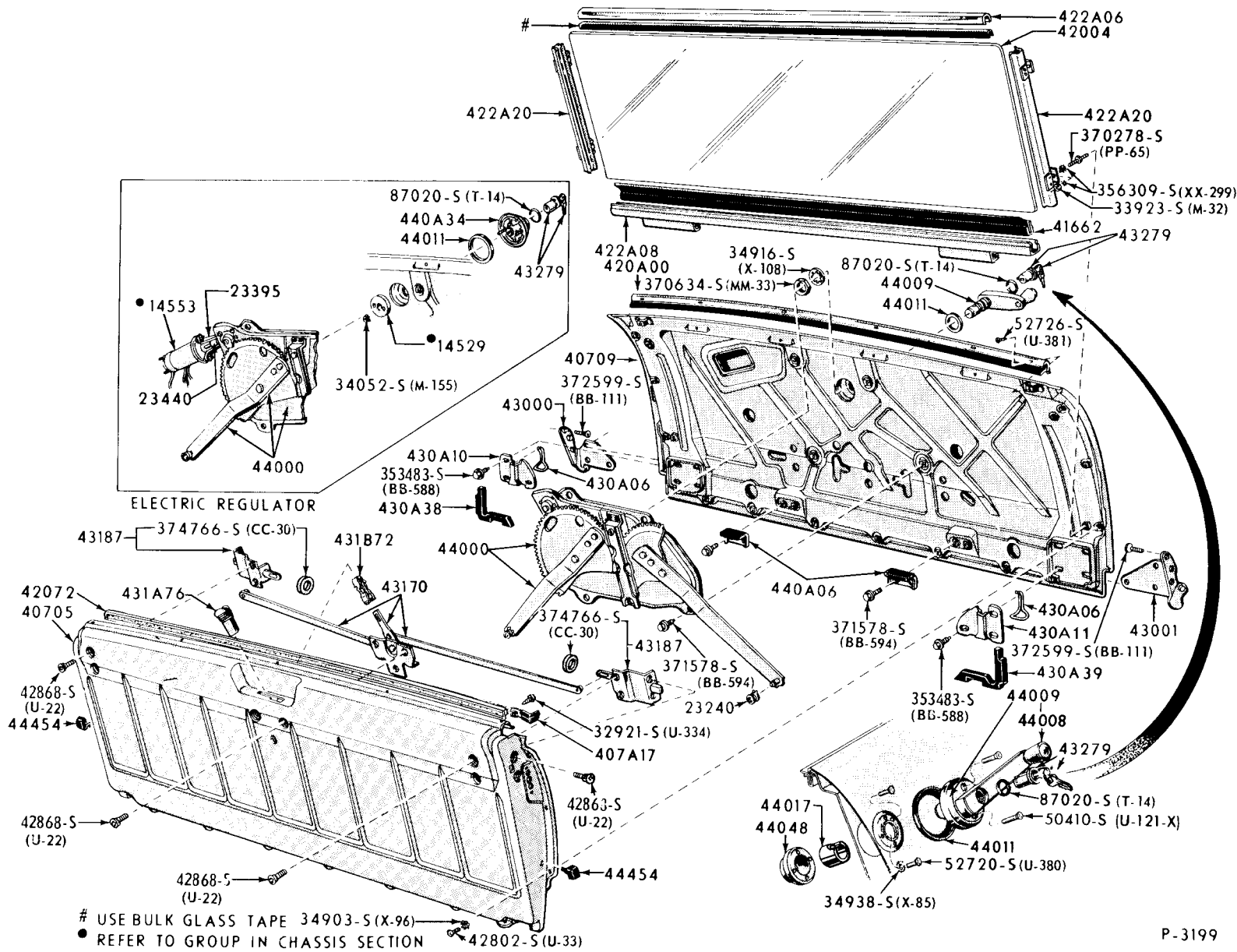

USE BULK GLASS TAPE 34903-S (X-96)
 • REFER TO GROUP IN CHASSIS SECTION

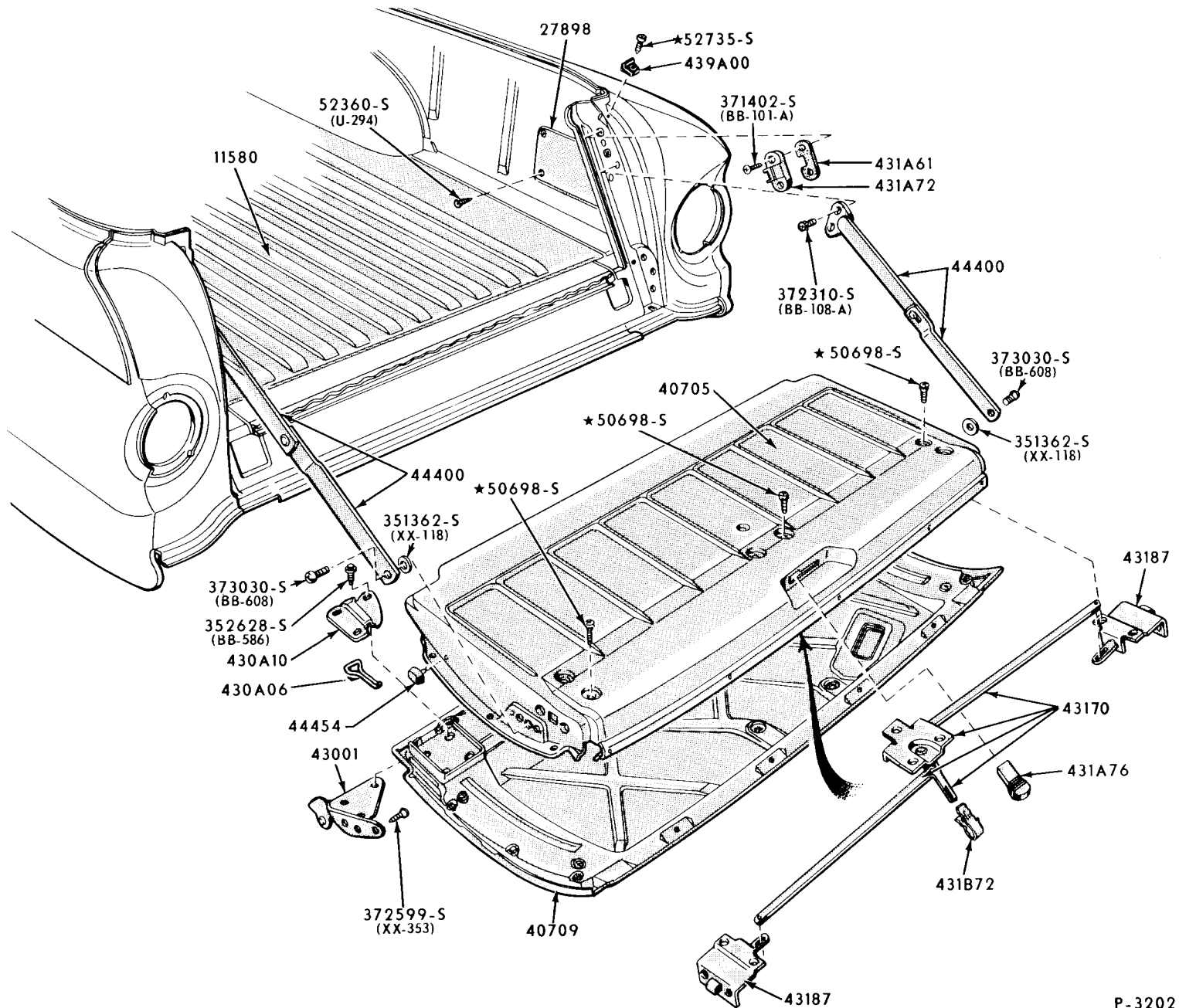

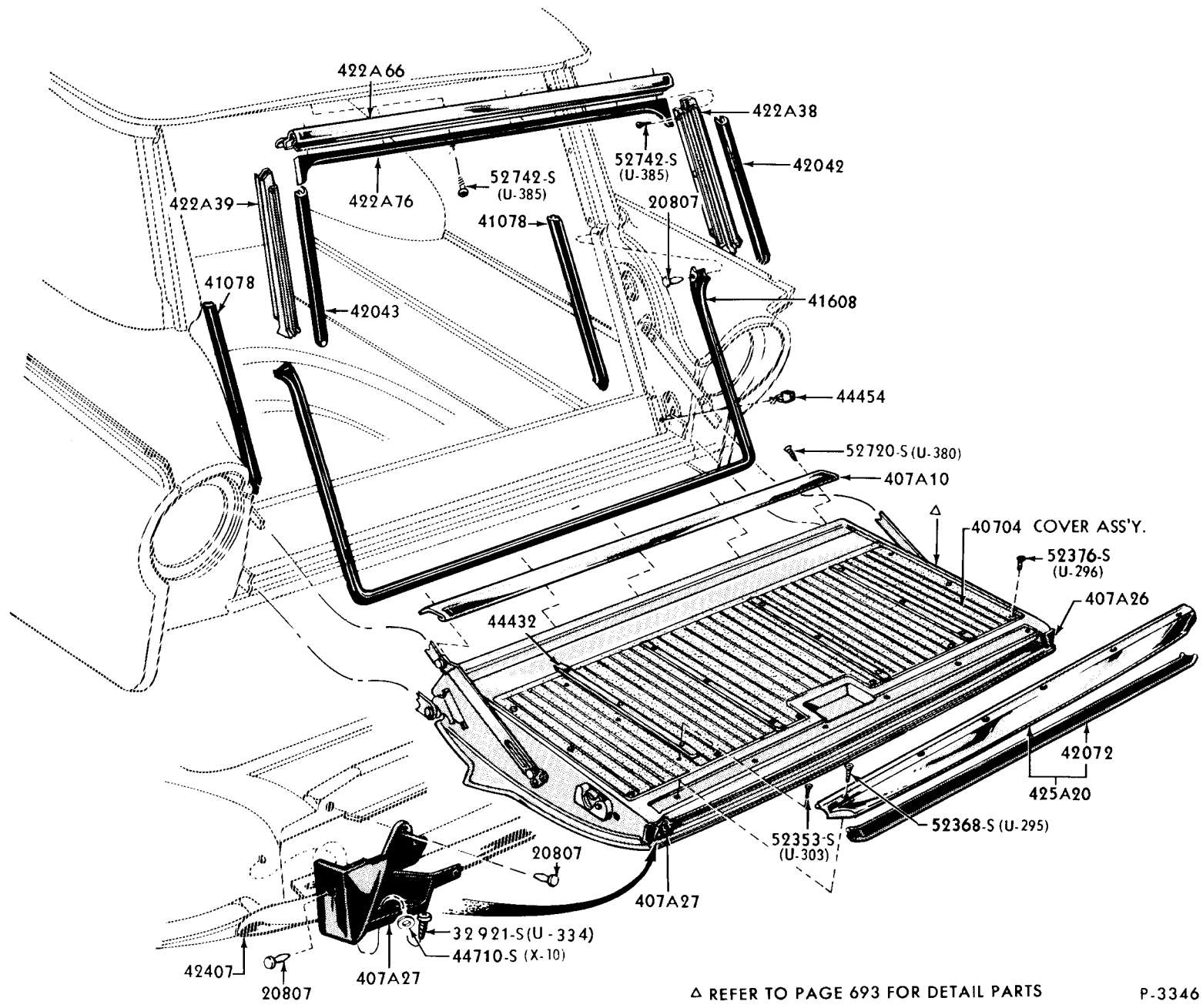

1961 RANCH & STATION WAGON TAIL GATE WEATHERSTRIPS & TRIM PARTS - BODY TYPES A (59, 71)

△ REFER TO PAGE 693 FOR DETAIL PARTS

P-3346

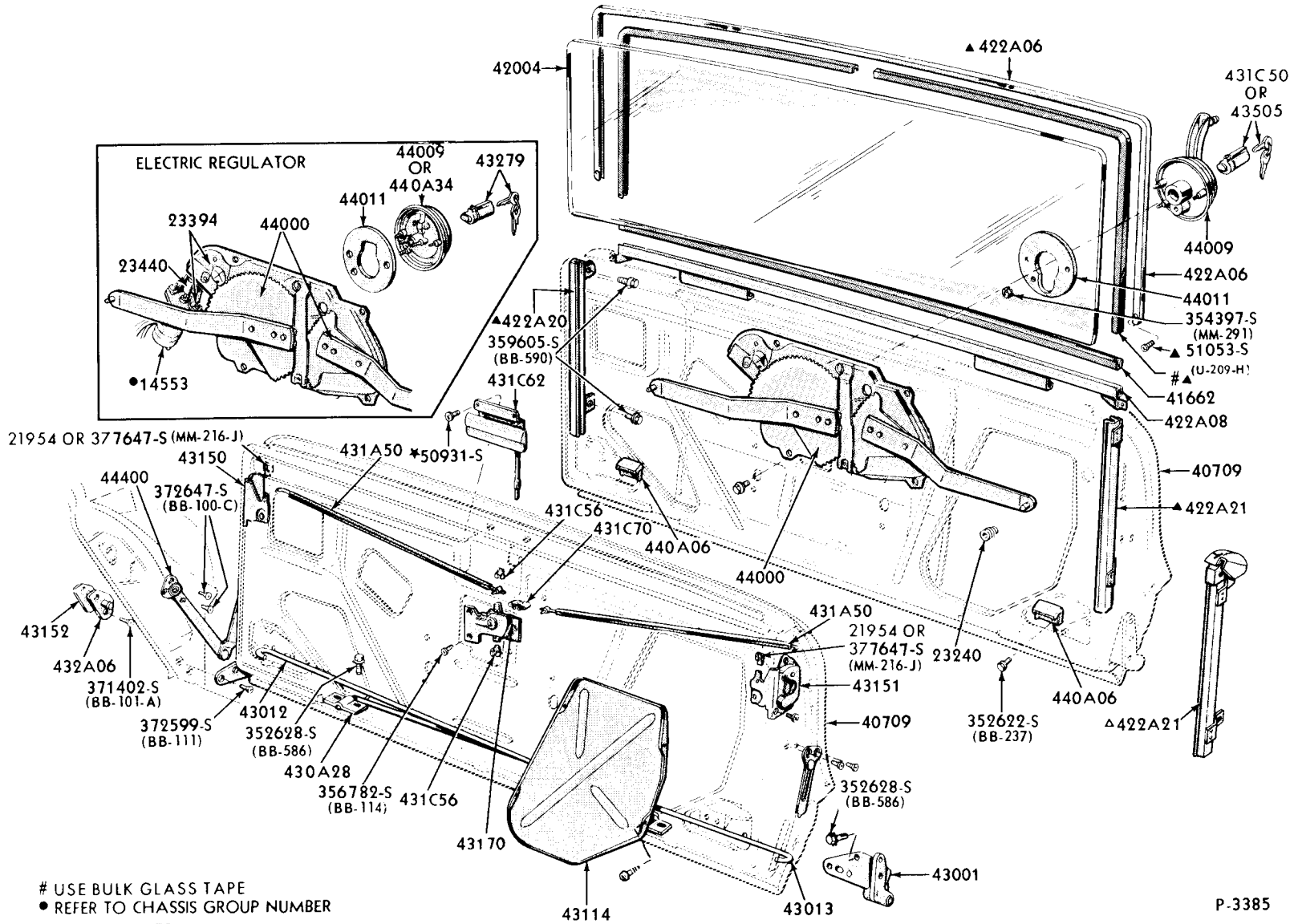

USE BULK GLASS TAPE
 ● REFER TO CHASSIS GROUP NUMBER
 ▲1961/63 UNITS
 △1964 UNITS

P-3385

1962 STATION WAGON TAIL GATE WEATHERSTRIPS & TRIM PARTS-BODY TYPE A(71)

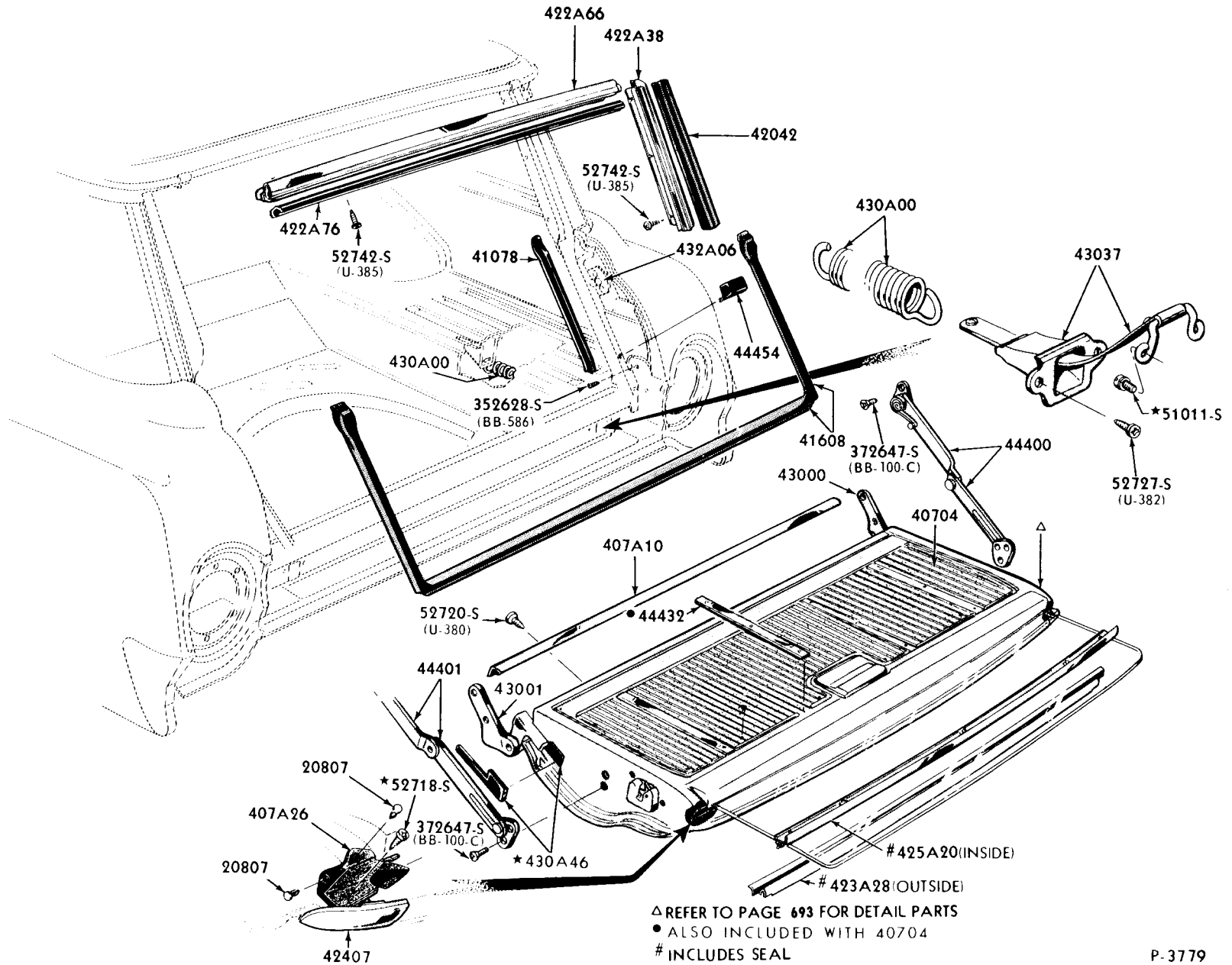

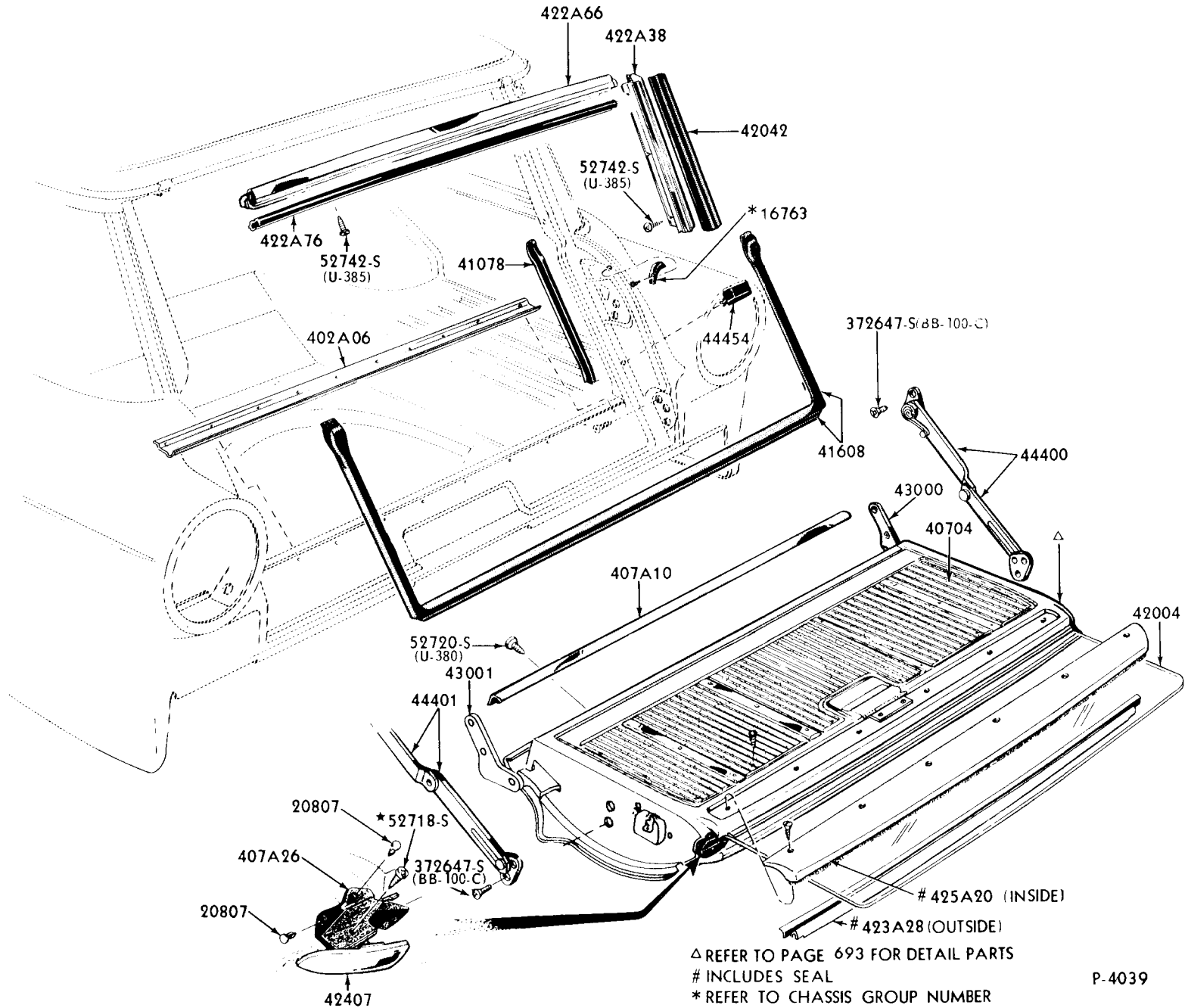

△ REFER TO PAGE 693 FOR DETAIL PARTS
 # INCLUDES SEAL
 * REFER TO CHASSIS GROUP NUMBER

P-4039

1964 STATION WAGON TAIL GATE WEATHERSTRIPS & RELATED PARTS-BODY TYPE A(71)

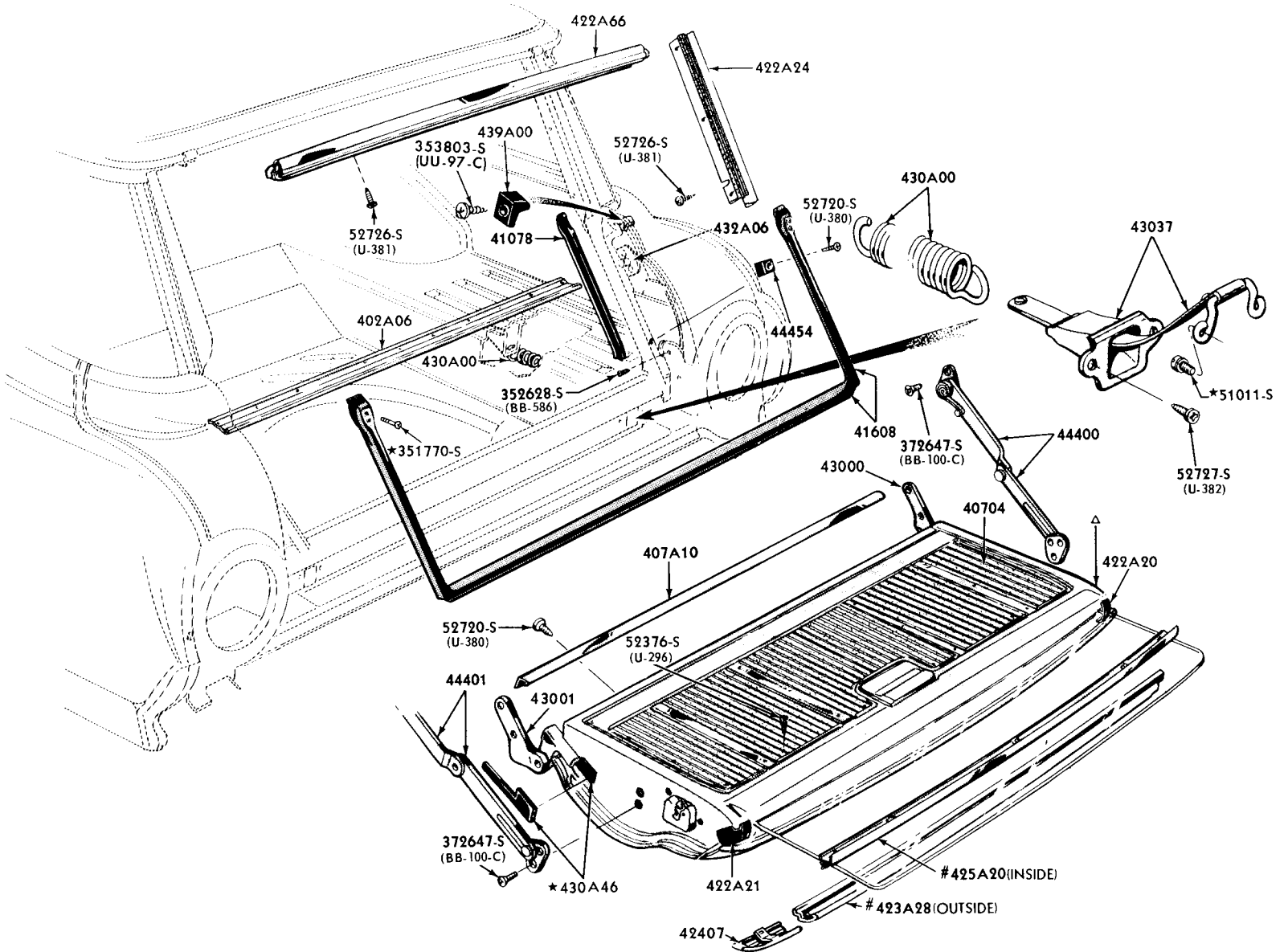

△ REFER TO PAGE 693 FOR DETAIL PARTS
INCLUDES SEAL

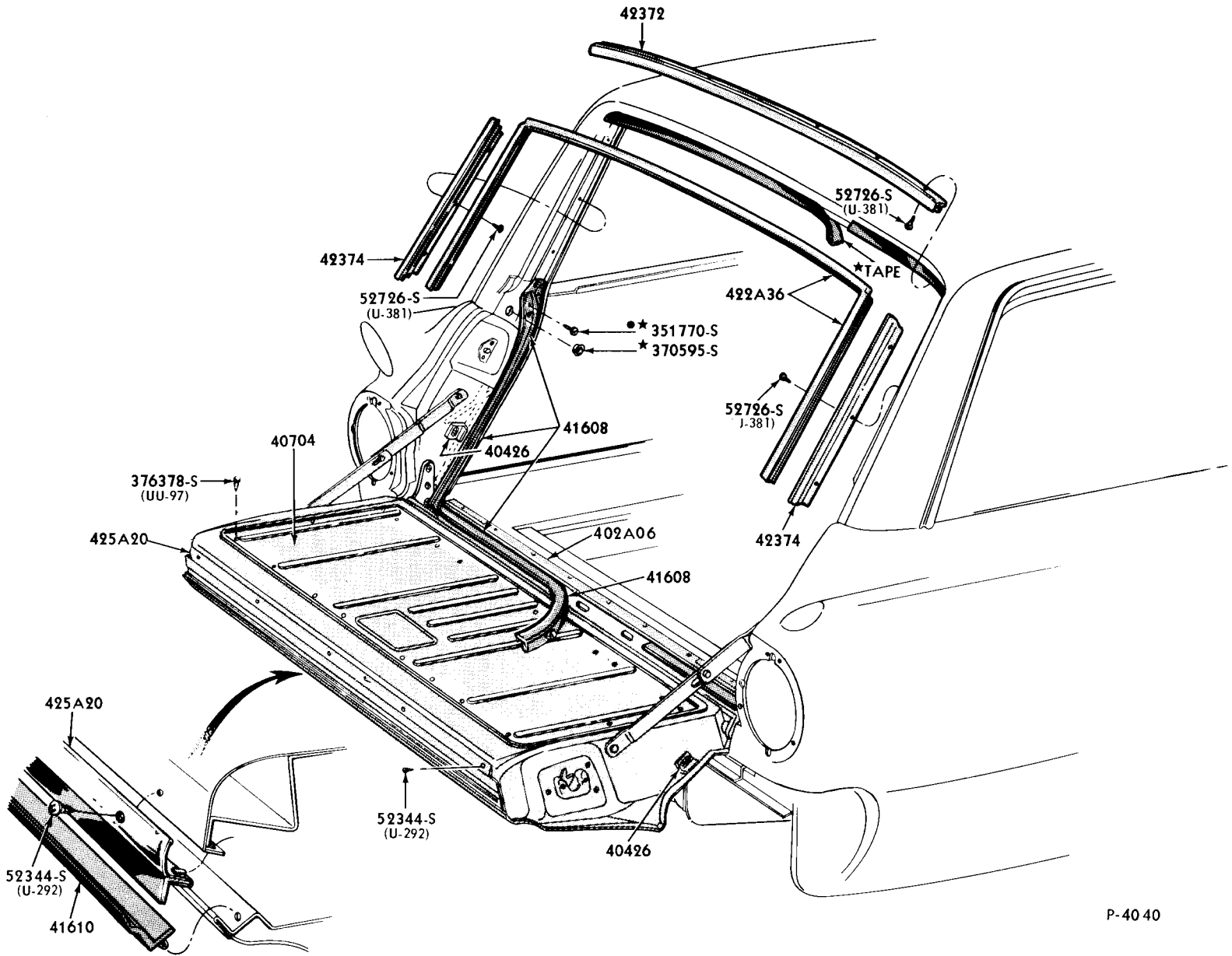

• FOR SERVICE USE 353803-S8

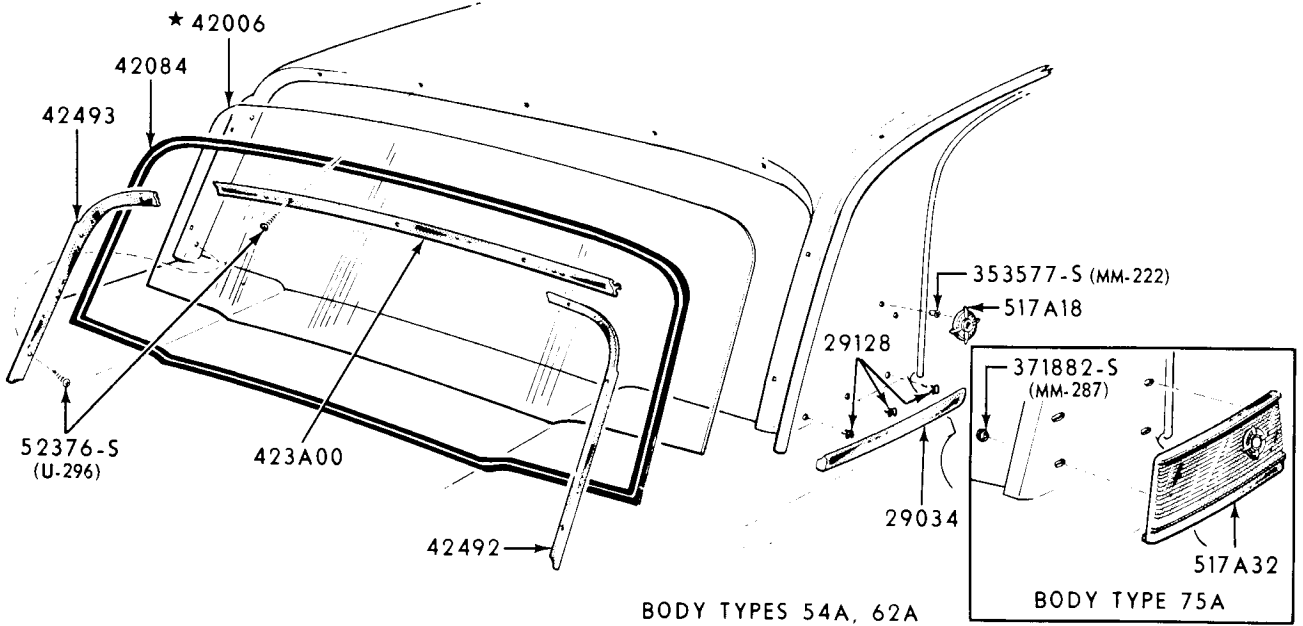

BODY TYPES 54A, 62A

BODY TYPE 75A

P-3016

1960 BACK WINDOW & RELATED PARTS - BODY TYPES A (54A, 62A, 75A)

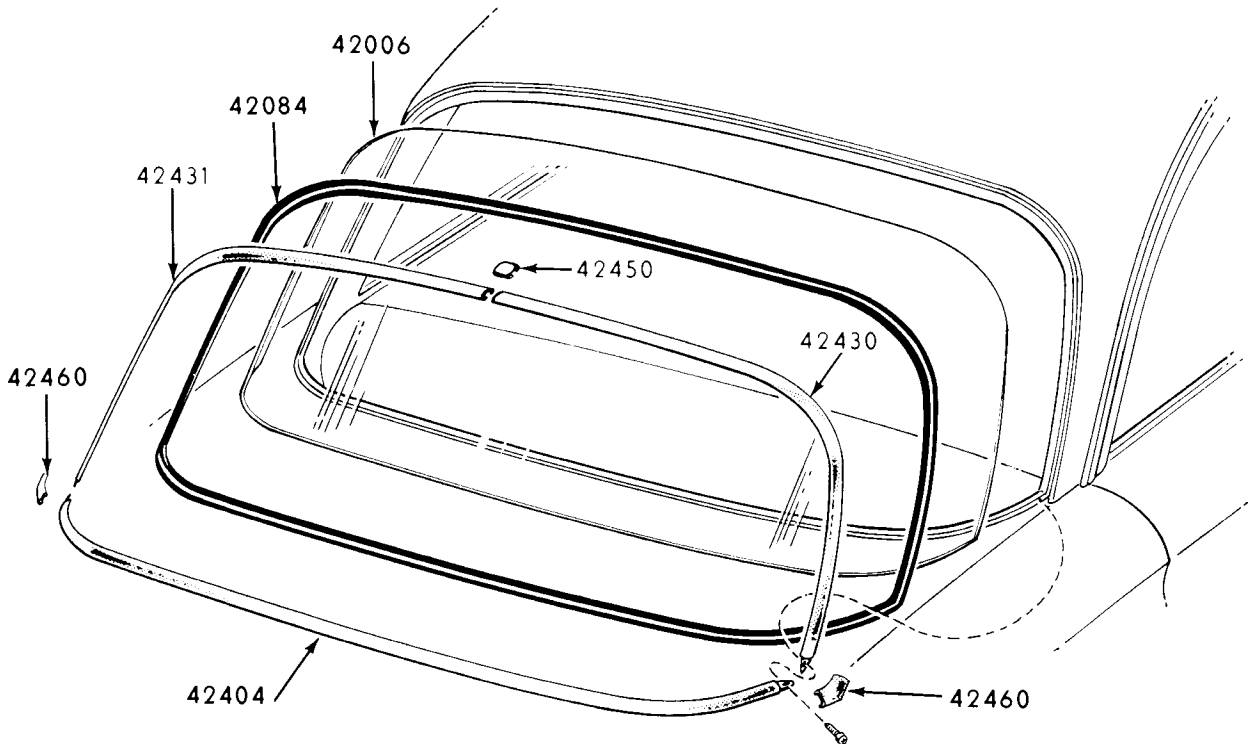

1960/62 FALCON BACK WINDOW & RELATED PARTS - BODY TYPE X(EXCEPT 62)

P-3017

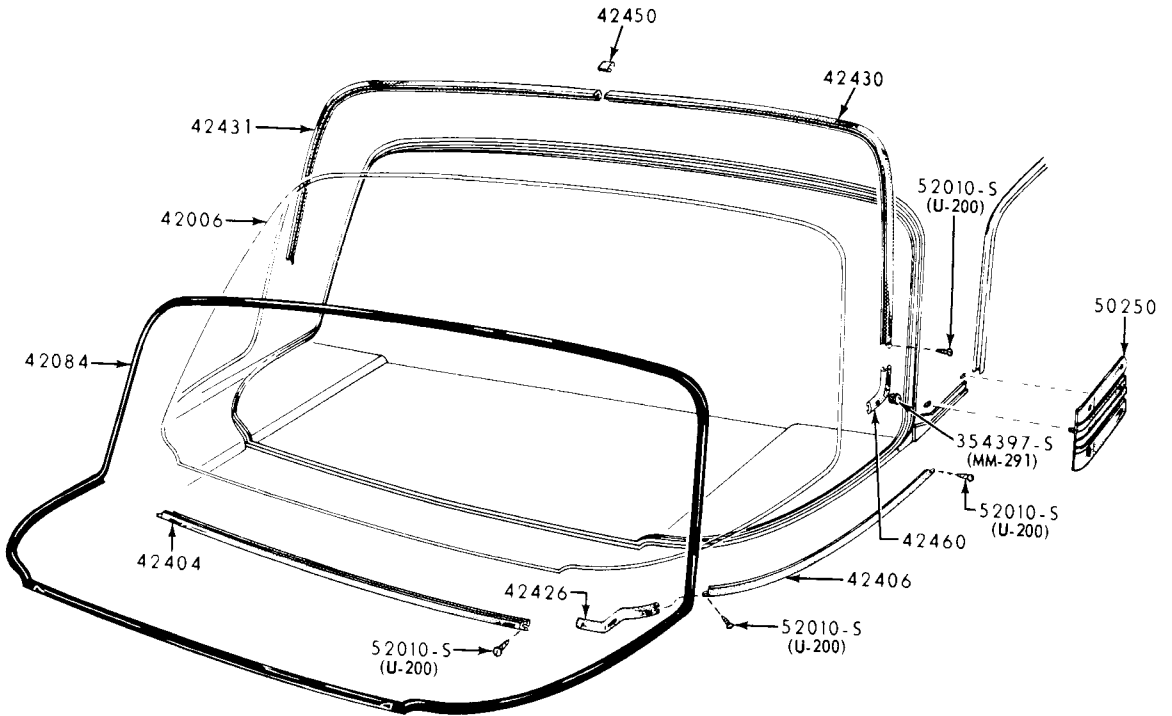

BACK WINDOW & RELATED PARTS
1960 FORD-BODY TYPE 63

P-3015

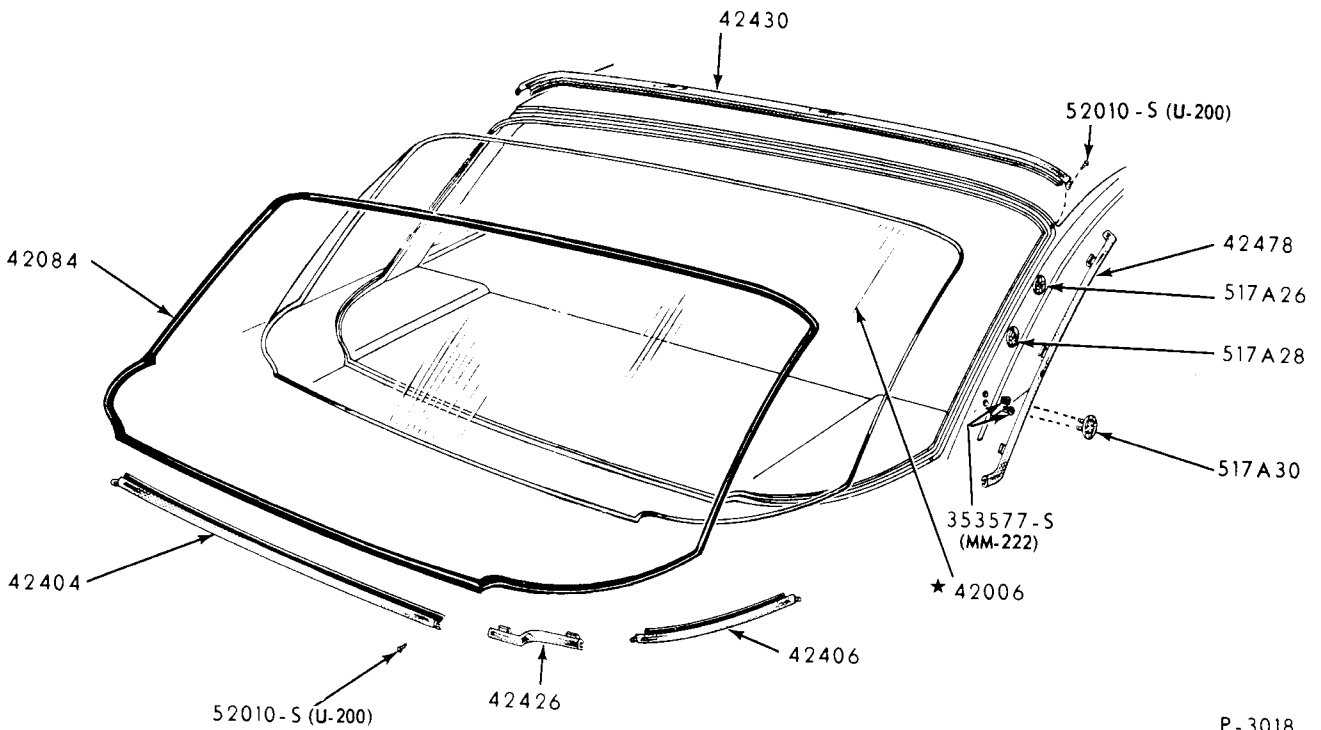

BACK WINDOW & RELATED PARTS
1960 FORD - BODY TYPES 58,64

P-3018

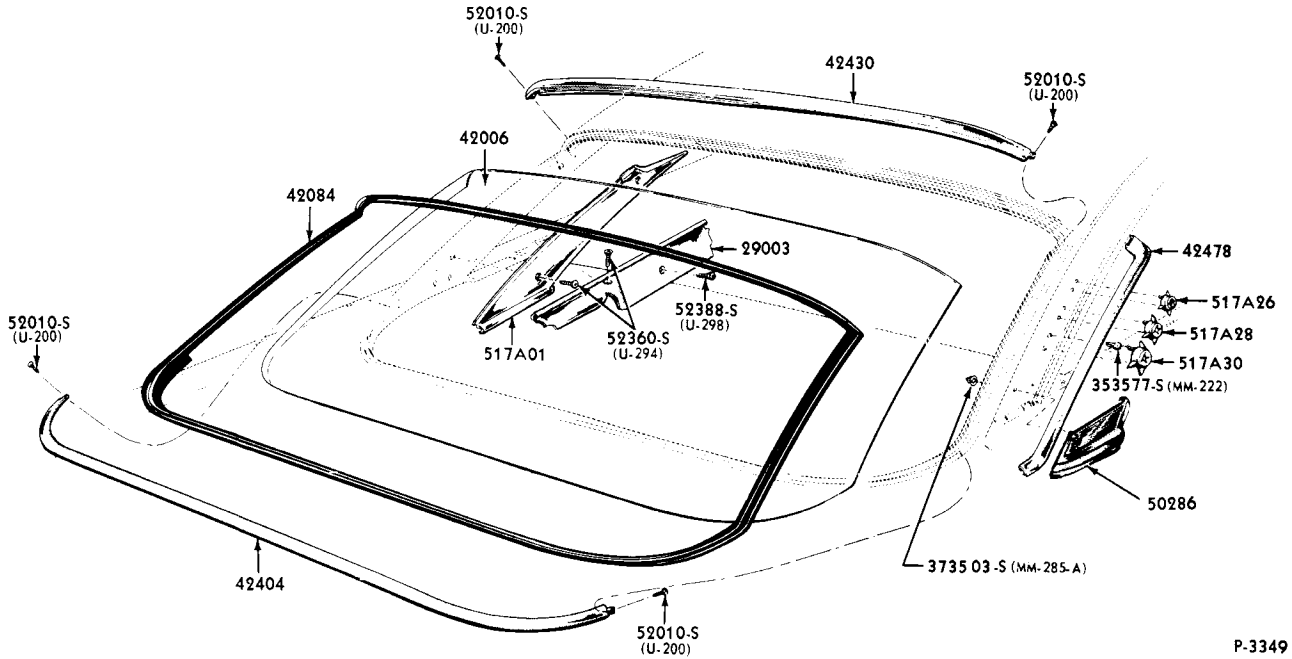

1961 BACK WINDOW & RELATED PARTS - BODY TYPE A (63A)

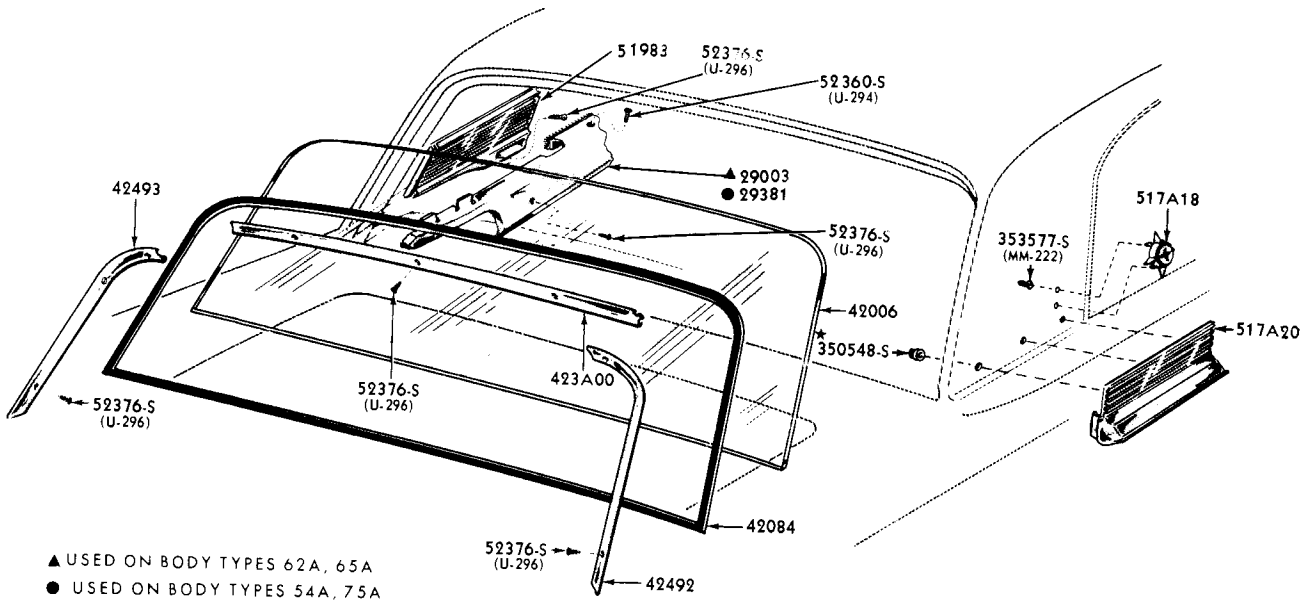

1961/63 TYPICAL BACK WINDOW & RELATED PARTS - BODY TYPES A (54, 62, 65, 75)

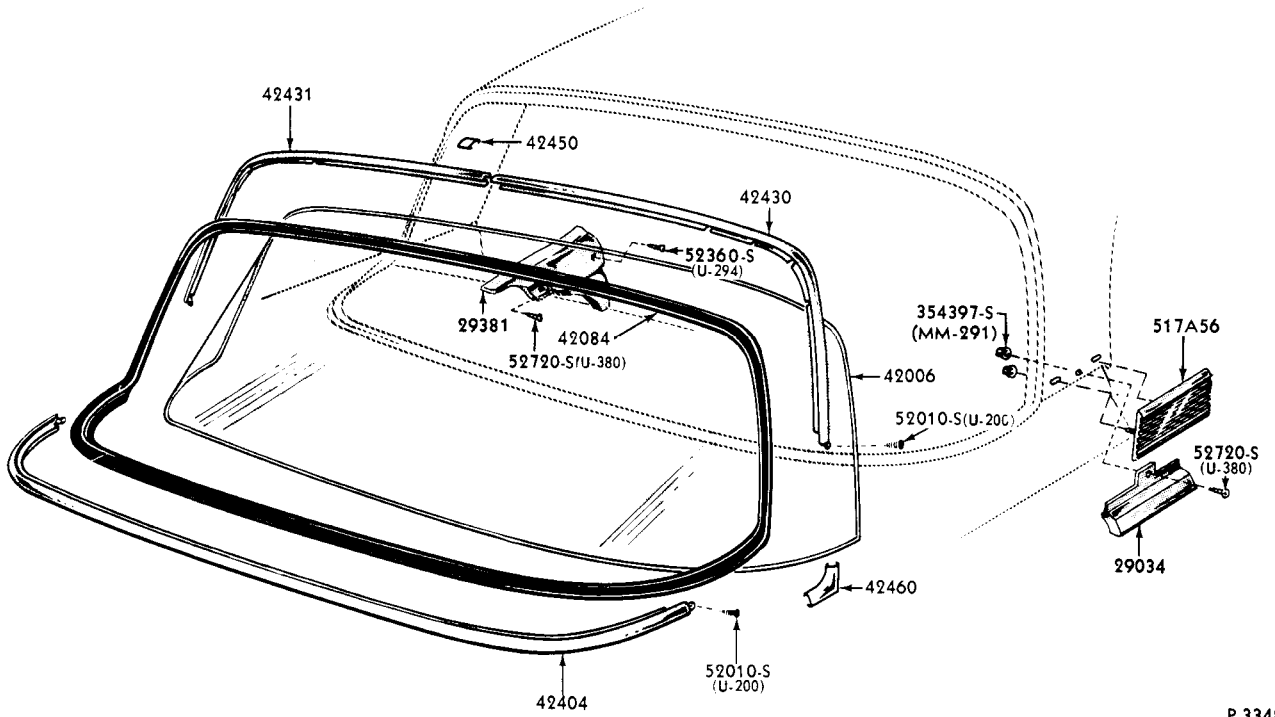

P-3348

1961 BACK WINDOW & RELATED PARTS - BODY TYPES A (58, 64)

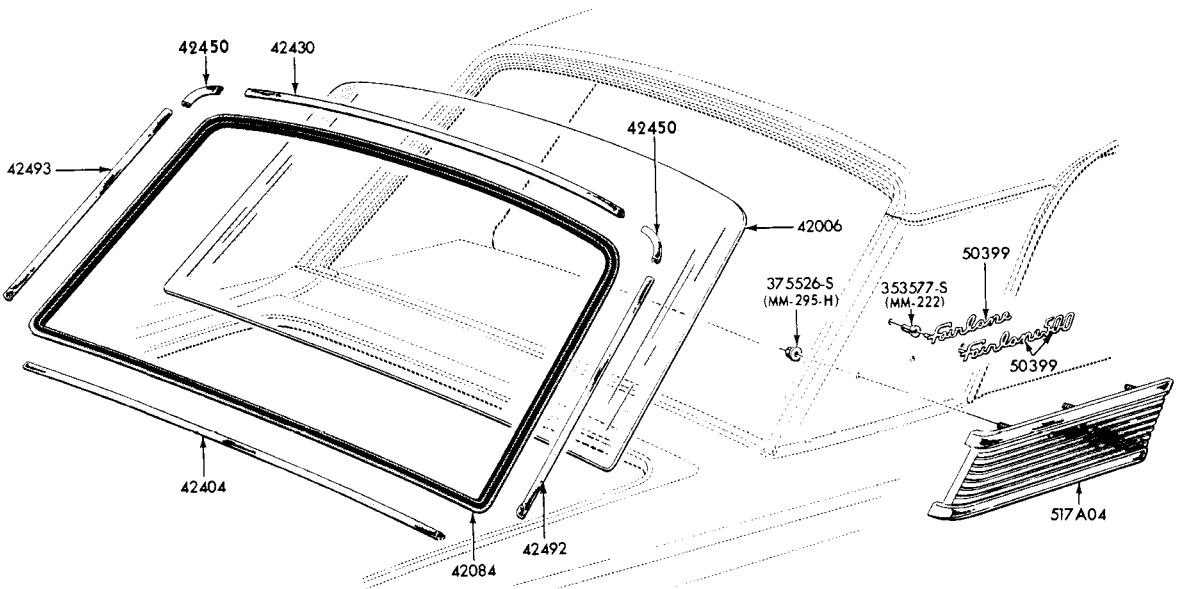

P-3760

1962/ FAIRLANE BACK WINDOW & RELATED PARTS - BODY TYPE B(54, 62)-TYPICAL

1961/63 THUNDERBIRD BACK WINDOW & RELATED PARTS-BODY TYPE S (63)

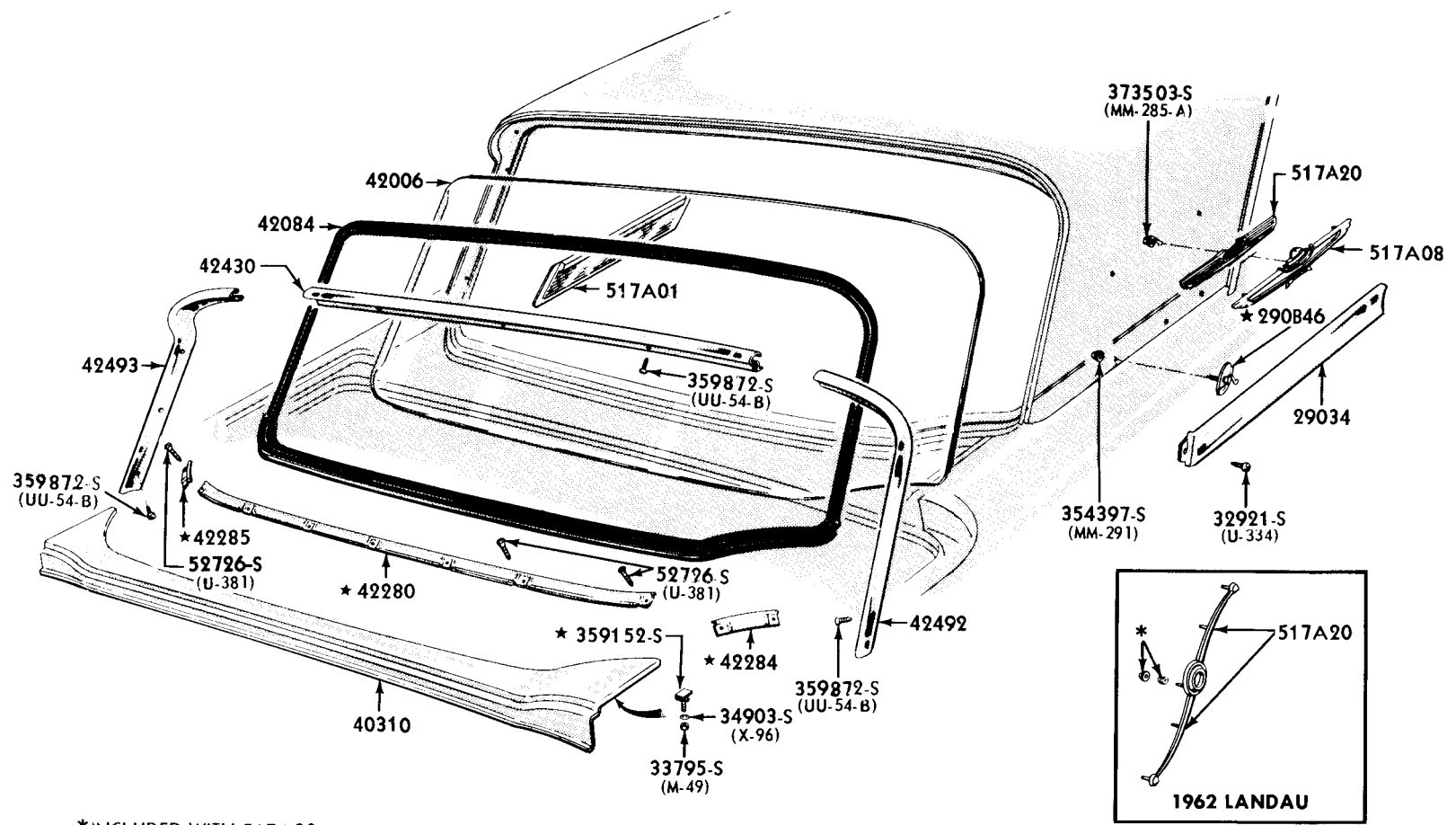

*INCLUDED WITH 517A20

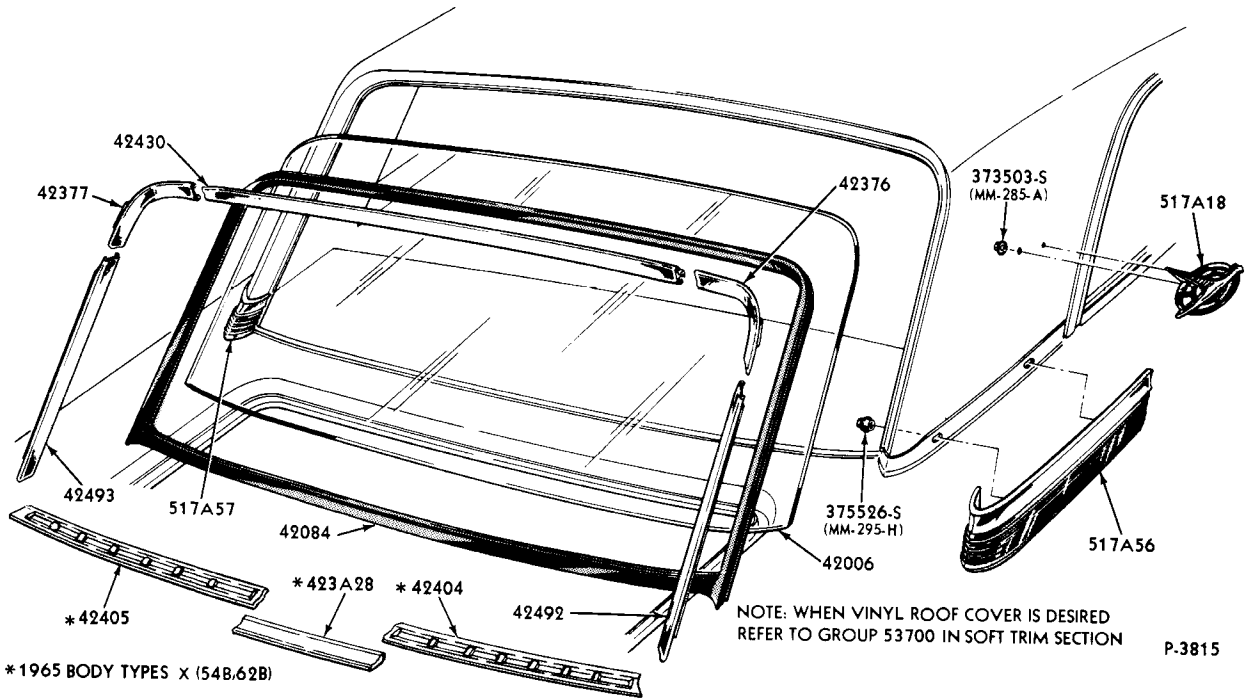

*1965 BODY TYPES X (54B,62B)

1962 FALCON BACK WINDOW & RELATED PARTS - BODY TYPE X(62C)

1963/ FALCON BACK WINDOW & RELATED PARTS - BODY TYPE X(54, 62) - TYPICAL

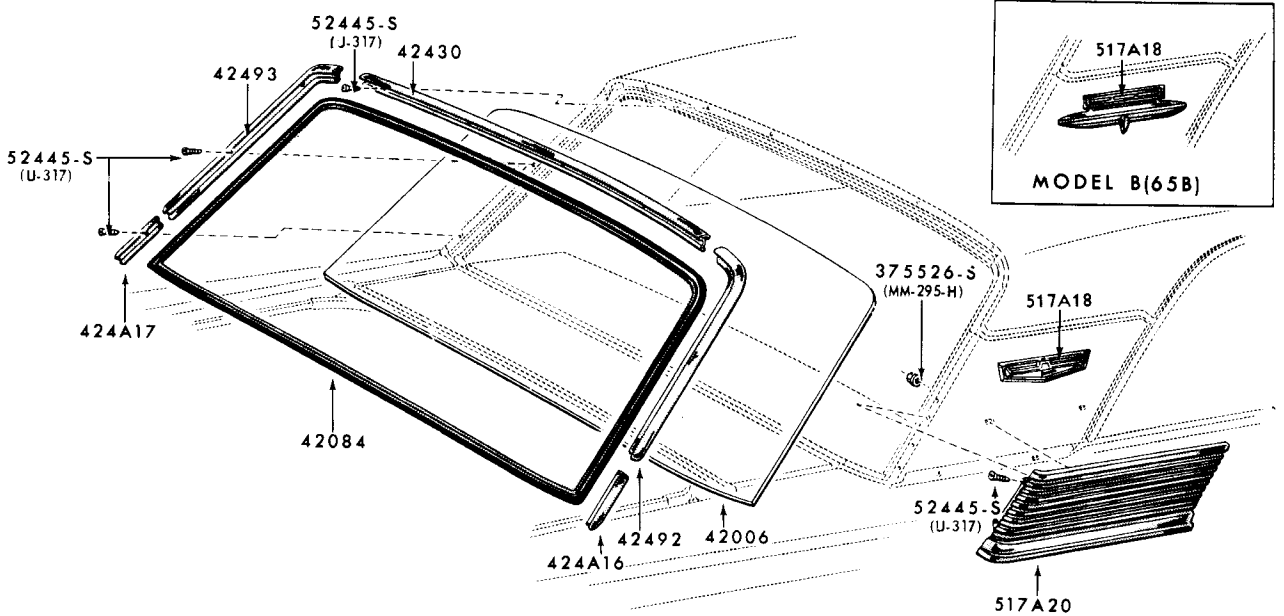

P.4037

1963/ FAIRLANE BACK WINDOW & RELATED PARTS - BODY TYPE B (65)

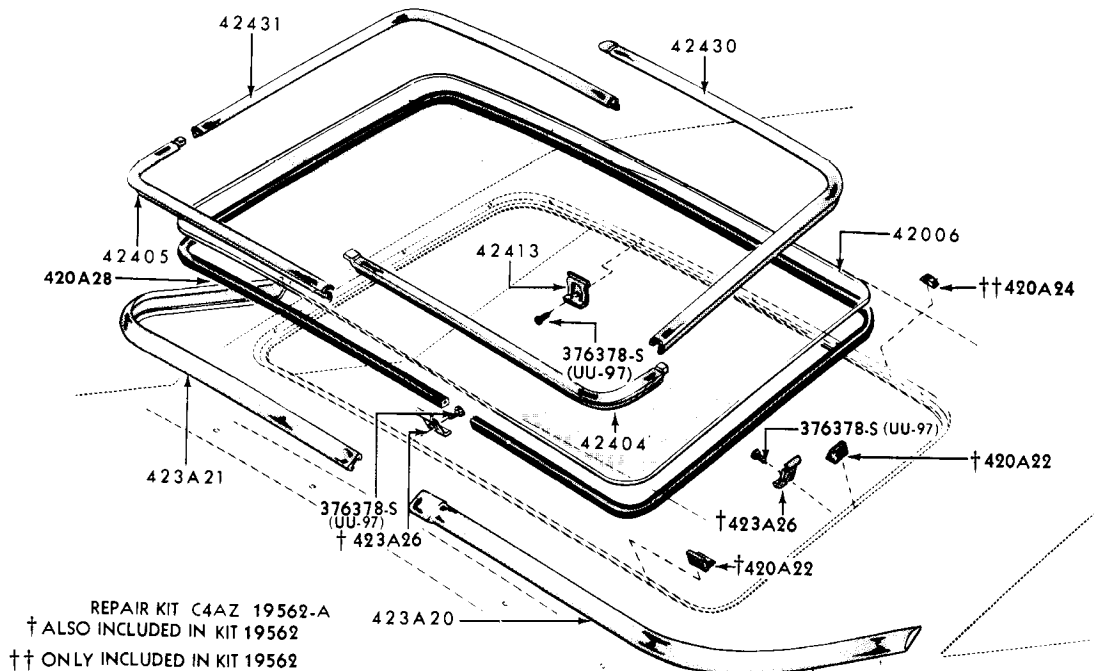

REPAIR KIT C4AZ 19562-A
 † ALSO INCLUDED IN KIT 19562
 †† ONLY INCLUDED IN KIT 19562

1964 ADHESIVE INSTALLATION

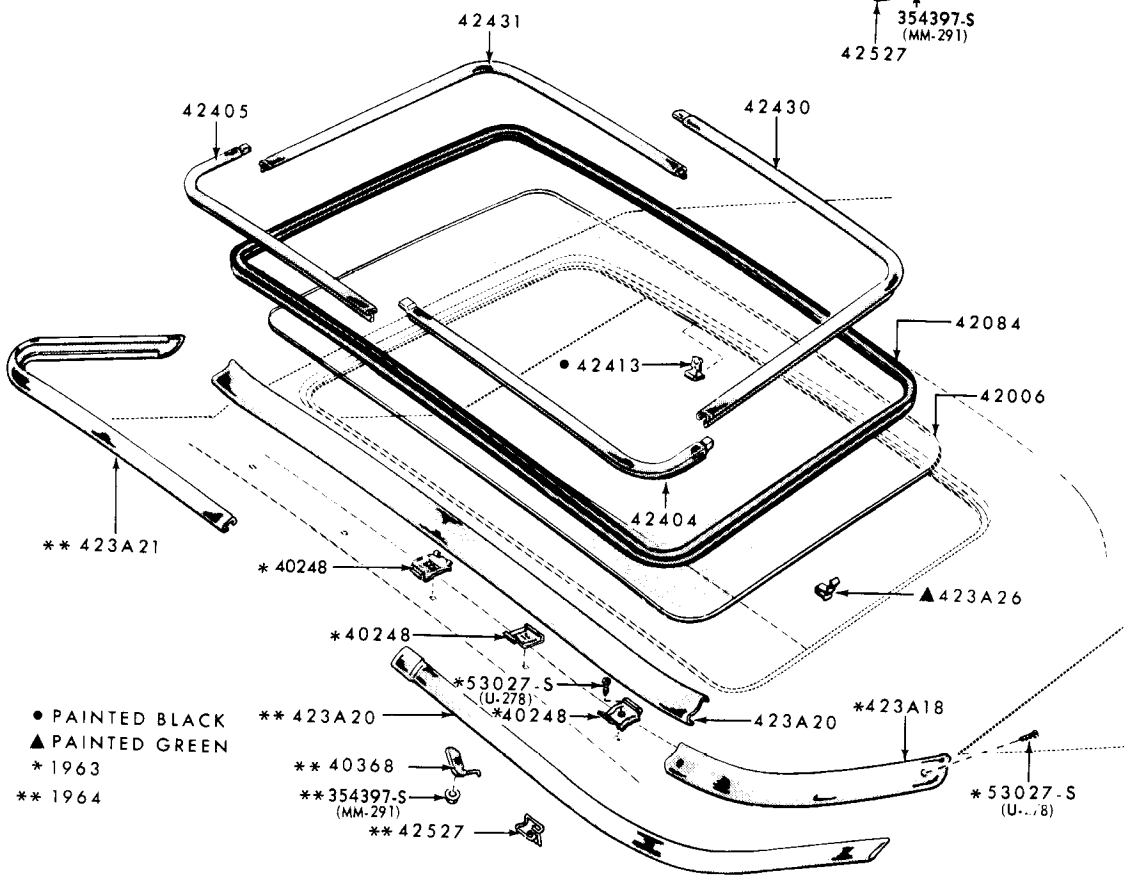

● PAINTED BLACK
 ▲ PAINTED GREEN
 * 1963
 ** 1964

WEATHERSTRIP INSTALLATION

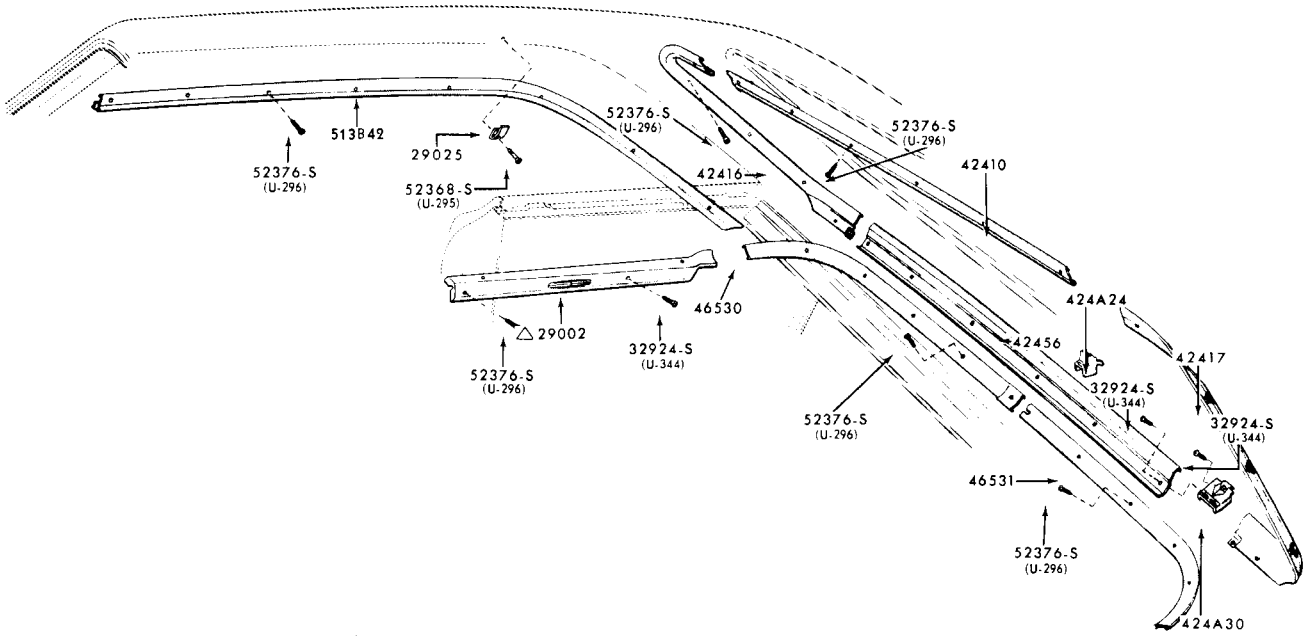

△ 1963 MODEL A(63B) FOR A(63C) AND 1964 A(63B,63C) USE #31012.3
 * REFER TO SOFT TRIM SECTION

P-4089

1963/64 BACK WINDOW & BODY SIDE INSIDE MOULDINGS - BODY TYPE A(63) - TYPICAL

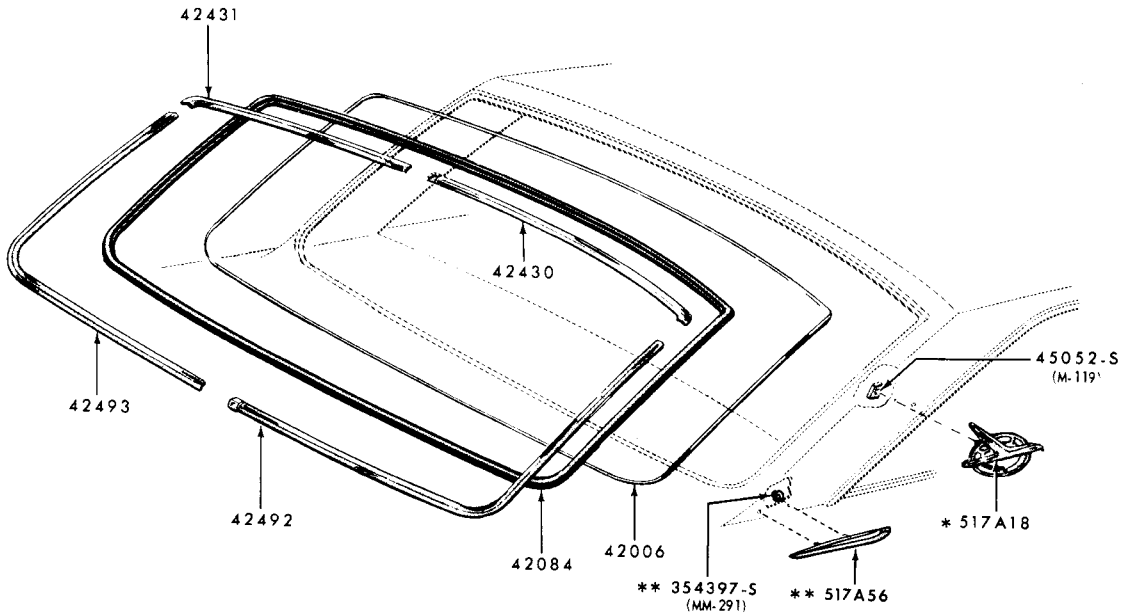

* 1963 UNITS
 ** 1964/ UNITS

P-3982

1963/ FALCON BACK WINDOW & RELATED PARTS - BODY TYPE X(63) - TYPICAL

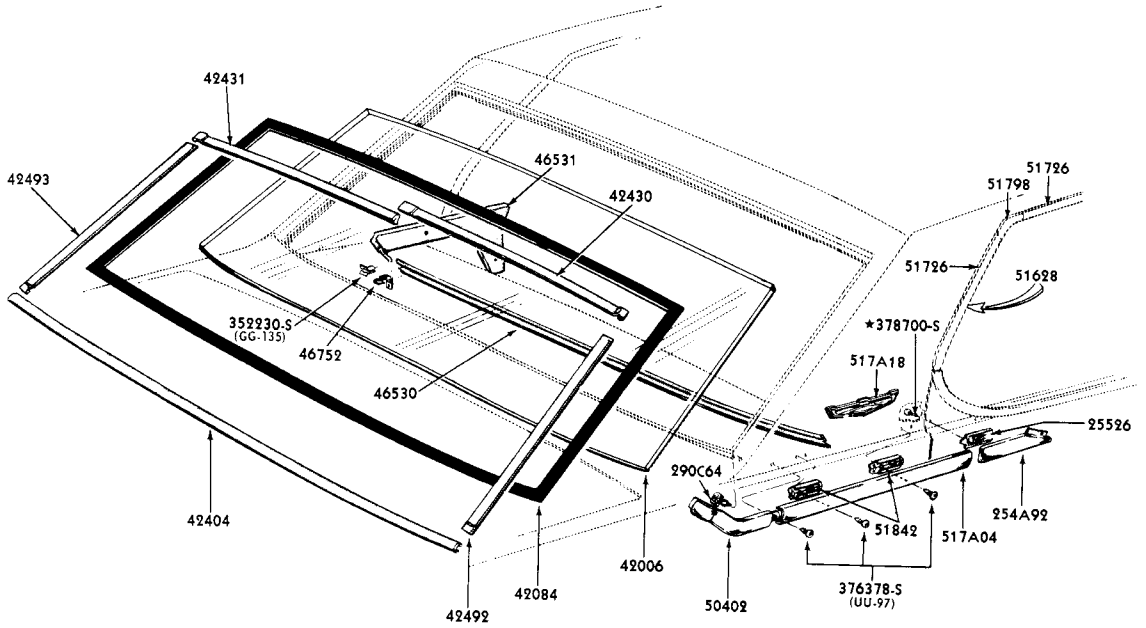

P-4347

1964 BACK WINDOW & RELATED PARTS - BODY TYPE A(54)

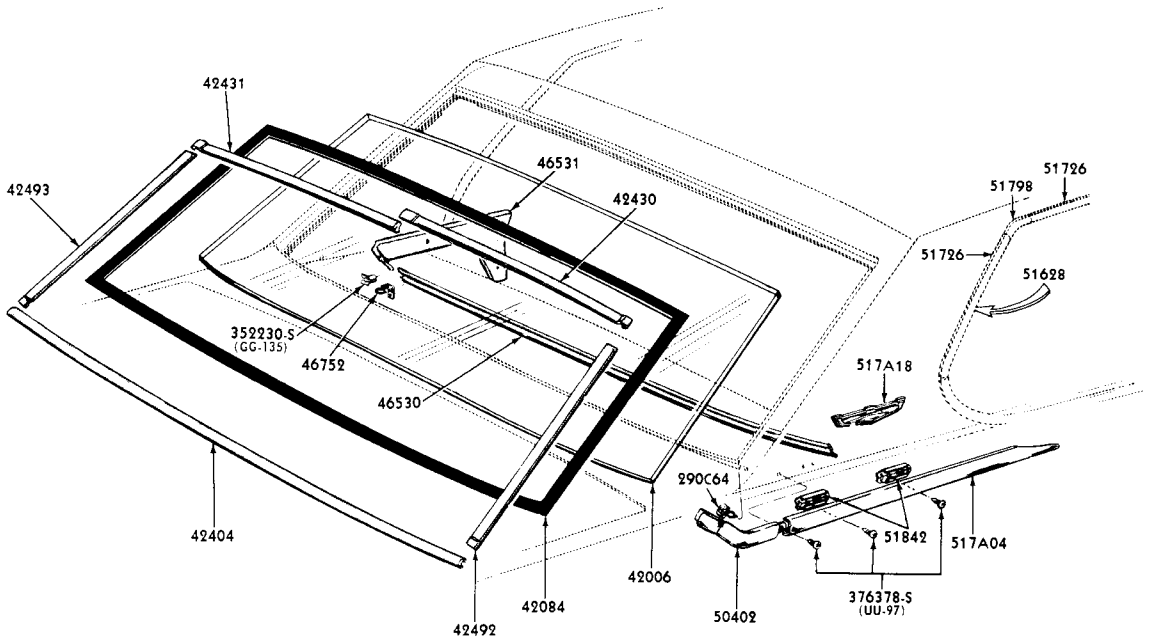

P-4392

1964 BACK WINDOW & RELATED PARTS - BODY TYPE A(62)

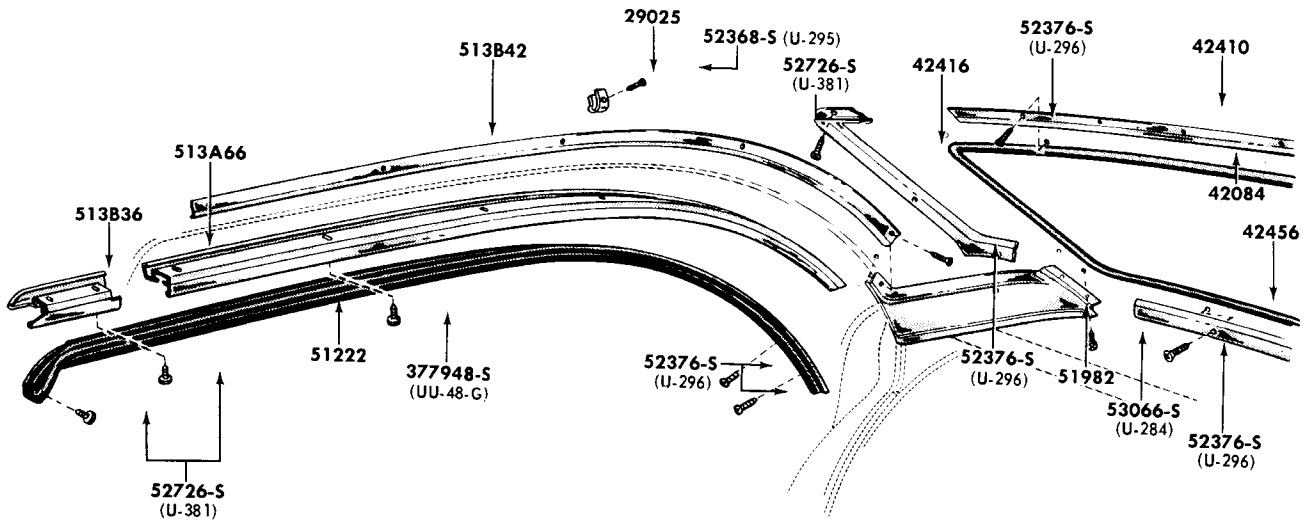

INSIDE

P-4356

INSIDE

1964 BACK WINDOW & ROOF SIDE MOULDING, WEATHERSTRIP & RELATED PARTS - BODY TYPE A(57)

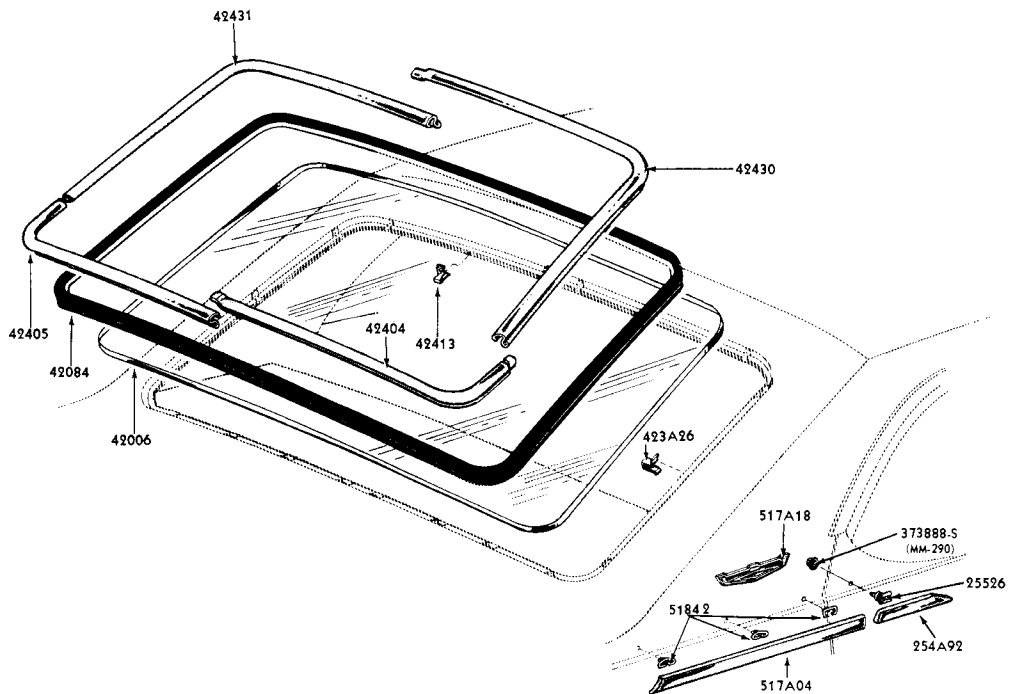

OUTSIDE

P-4348

1964 BACK WINDOW & RELATED PARTS - BODY TYPE A(57)

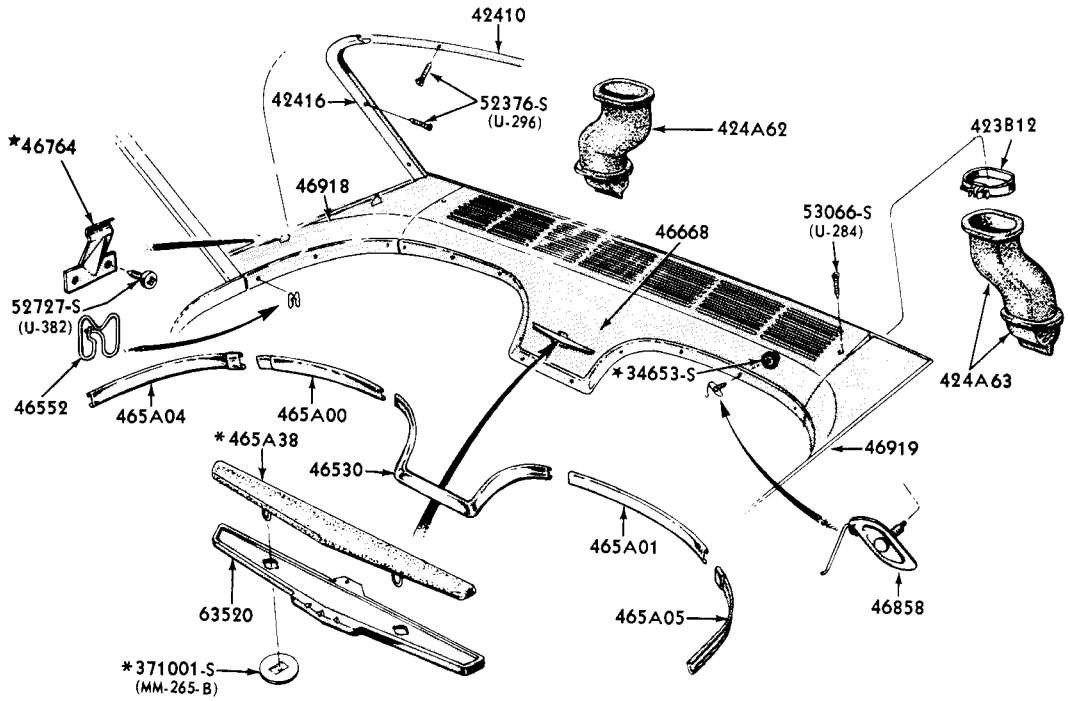

* REFER TO SOFT TRIM SECTION

P-4350

INSIDE

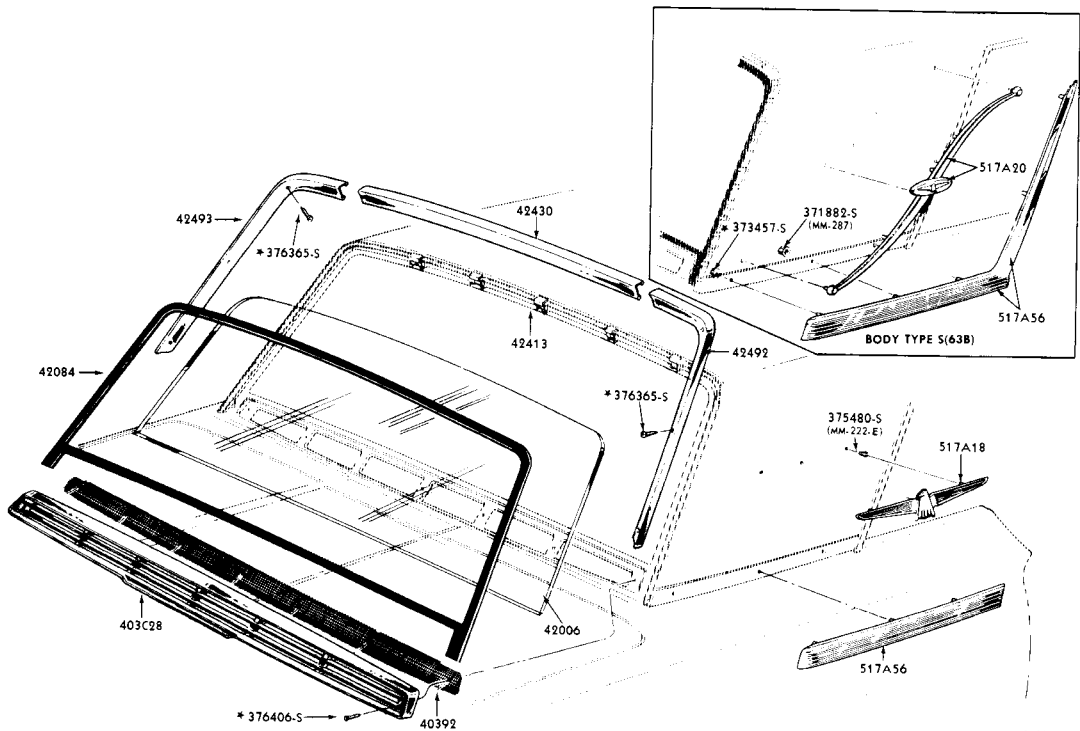

P-4349

OUTSIDE

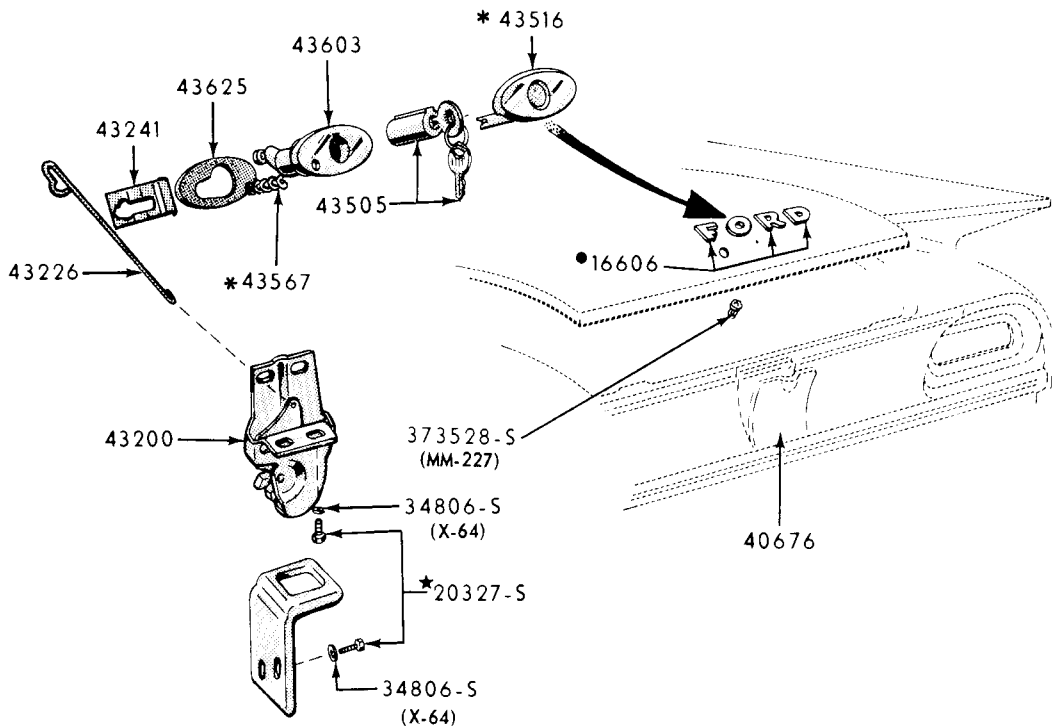

* ALSO INCLUDED IN 43603

● REFER TO CHASSIS GROUP

LUGGAGE COMPARTMENT DOOR LATCH and RELATED PARTS
1960 FORD - BODY TYPES 58E, 64F, G

P-3081

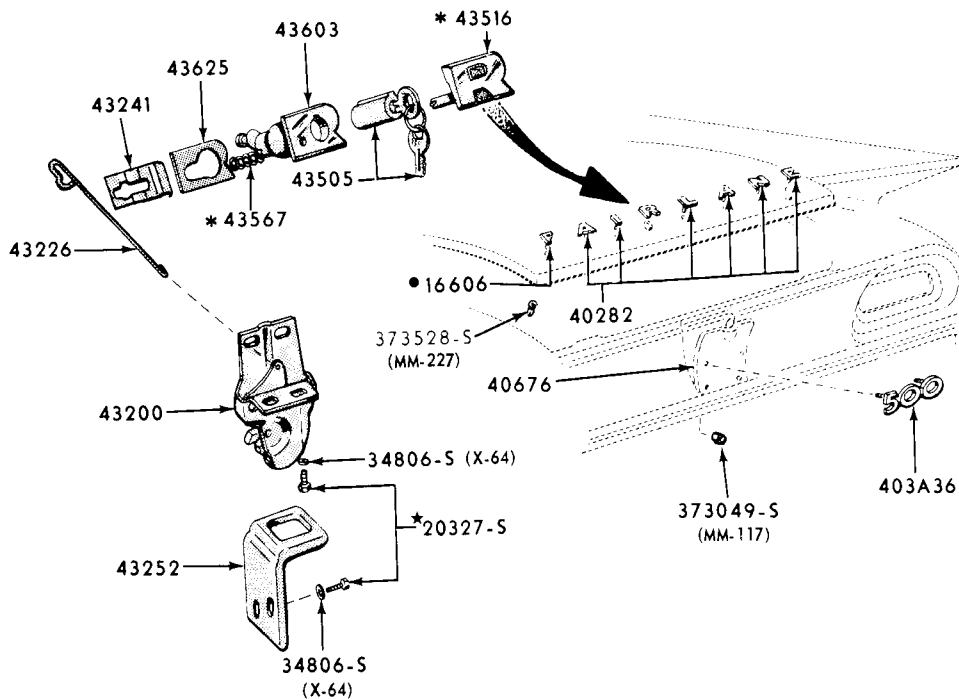

* ALSO INCLUDED IN 43603

● REFER TO CHASSIS GROUP

LUGGAGE COMPARTMENT DOOR LATCH and RELATED PARTS
1960 FORD - BODY TYPES 58A, 64A

P-3036

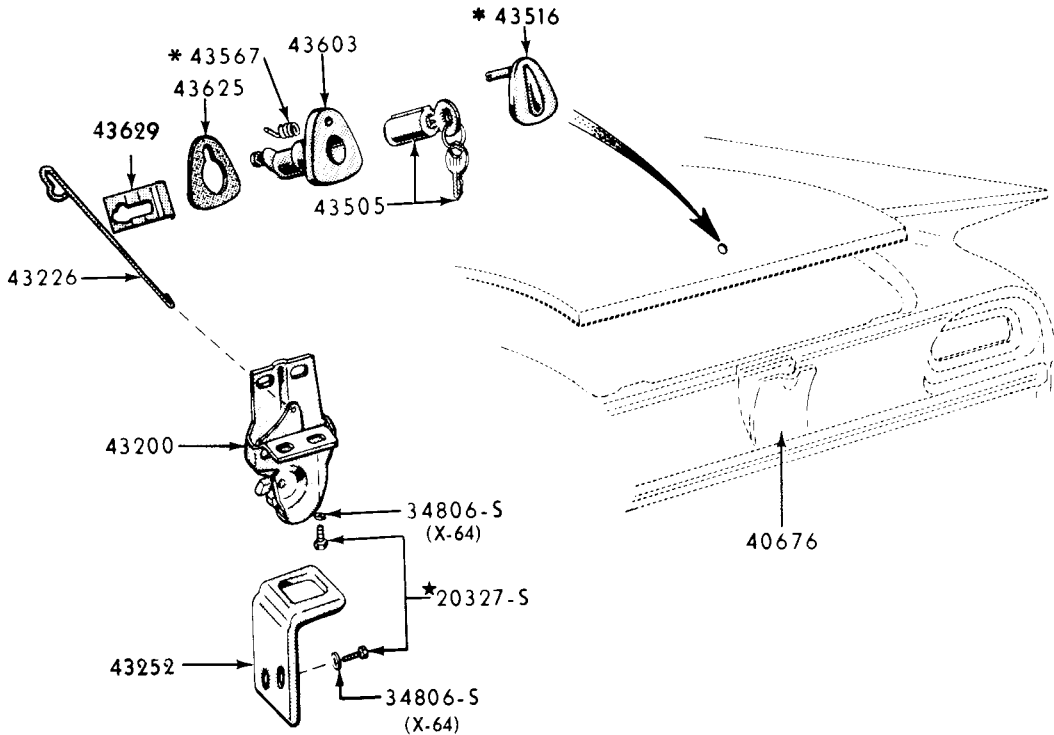

* ALSO INCLUDED IN 43603

P-3208

LUGGAGE COMPARTMENT DOOR LATCH and RELATED PARTS
1960 FORD - BODY TYPES 58F, 64H

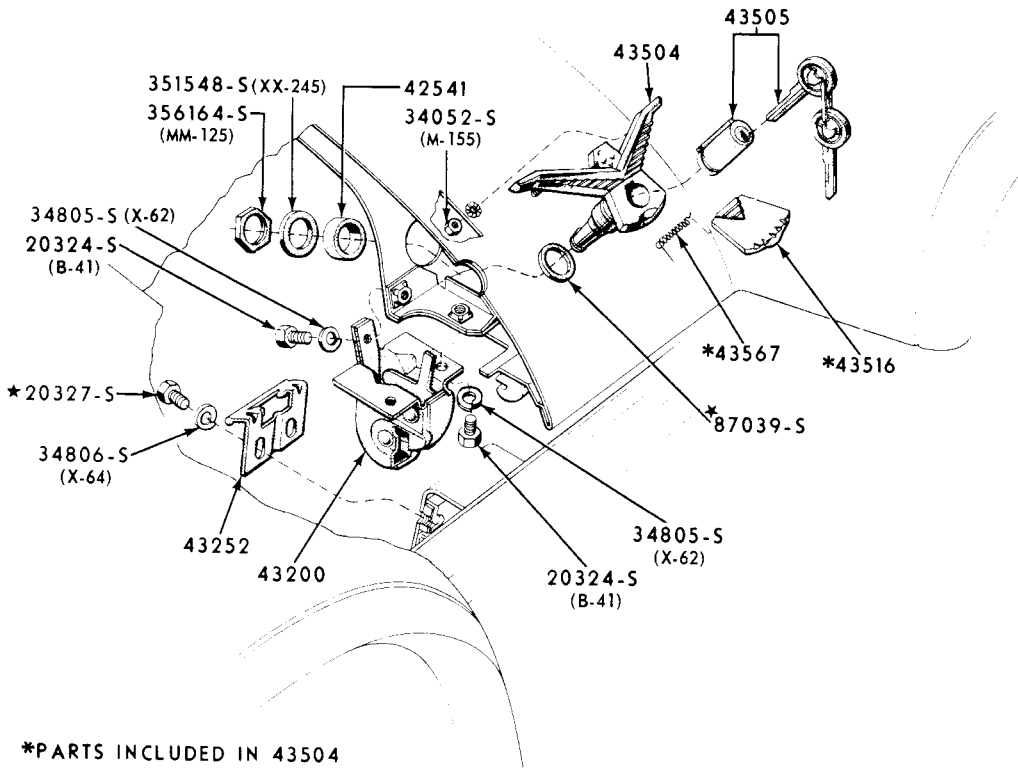

*PARTS INCLUDED IN 43504

P-2619

LUGGAGE COMPARTMENT DOOR LATCH and RELATED PARTS
1960 THUNDERBIRD - BODY TYPE 63A

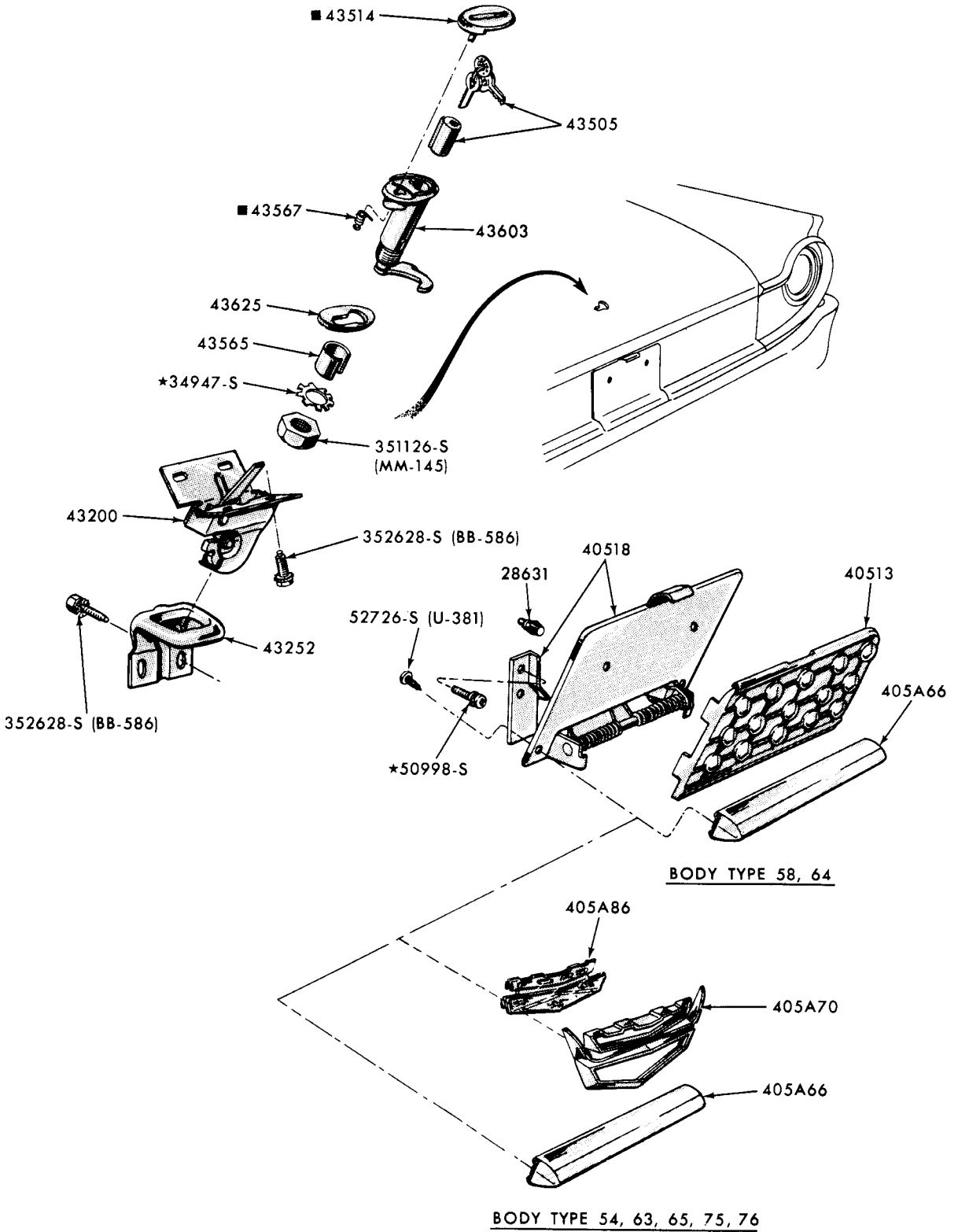

■ ALSO SERVICED IN ASSEMBLY—GROUP 43603

P-3351

LUGGAGE COMPARTMENT DOOR LATCH and RELATED PARTS
1961 FORD - BODY TYPES 54,58,63,64,65,75,76

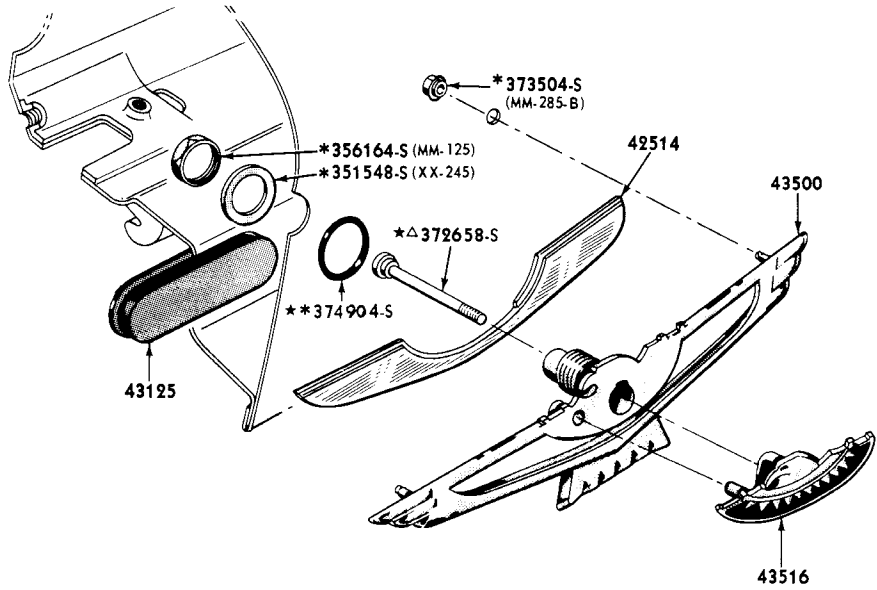

* ALSO INCLUDED WITH 43500
 Δ INCLUDED WITH 43516

P-3354

1961/63 THUNDERBIRD LUGGAGE COMPARTMENT DOOR ORNAMENT-BODY TYPE S (76)

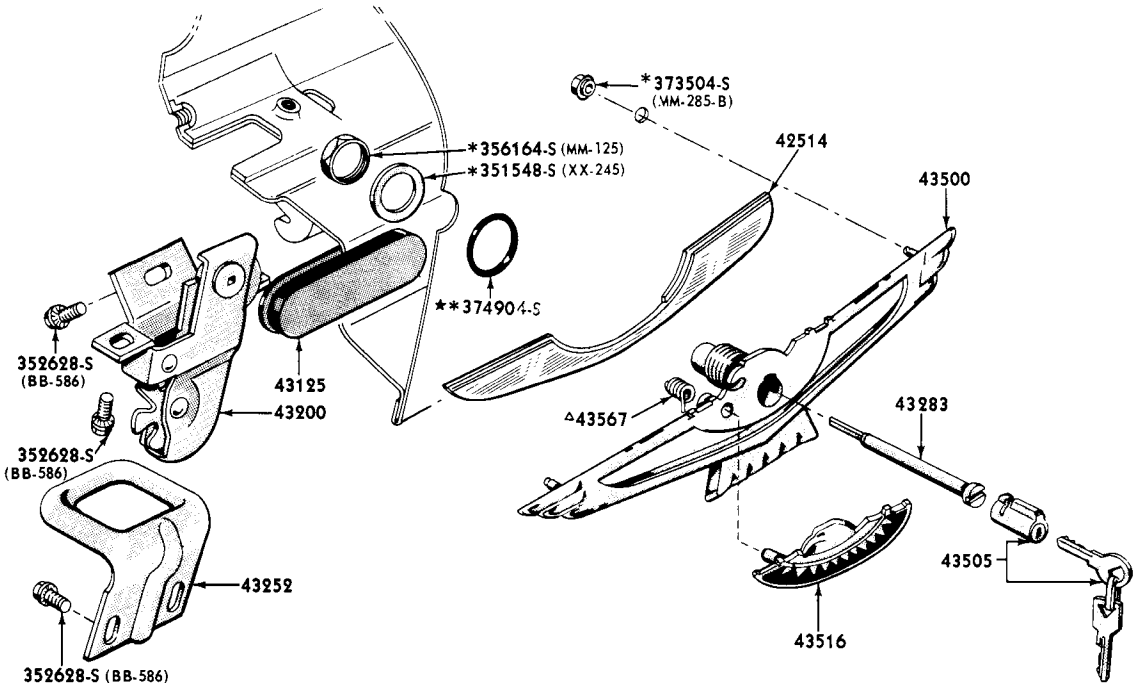

* ALSO INCLUDED WITH 43500
 Δ ALSO INCLUDED WITH 43516

P-3355

1961/63 THUNDERBIRD LUGGAGE COMPARTMENT DOOR LOCK & RELATED PARTS-BODY TYPE S(63)

BODY ILLUSTRATION SECTION 430 FORD CAR PARTS

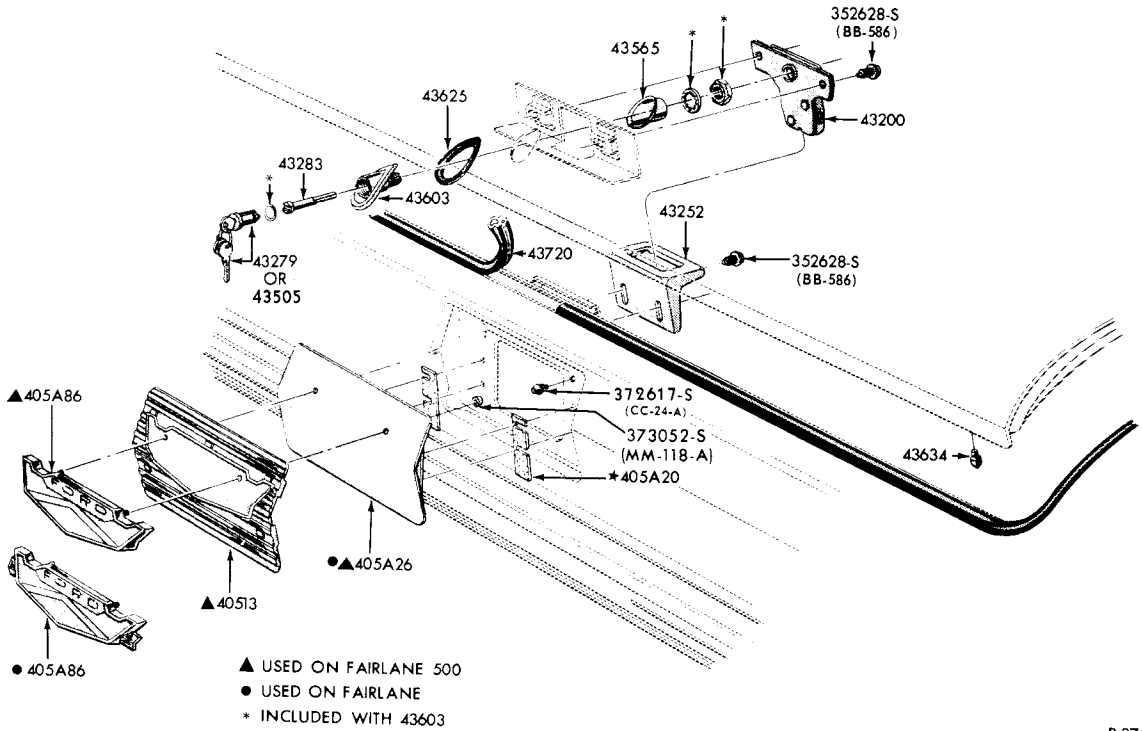

P-3761

1962/63 FAIRLANE TYPICAL LUGGAGE COMPARTMENT DOOR LOCK & RELATED PARTS - BODY TYPES B (except 71)

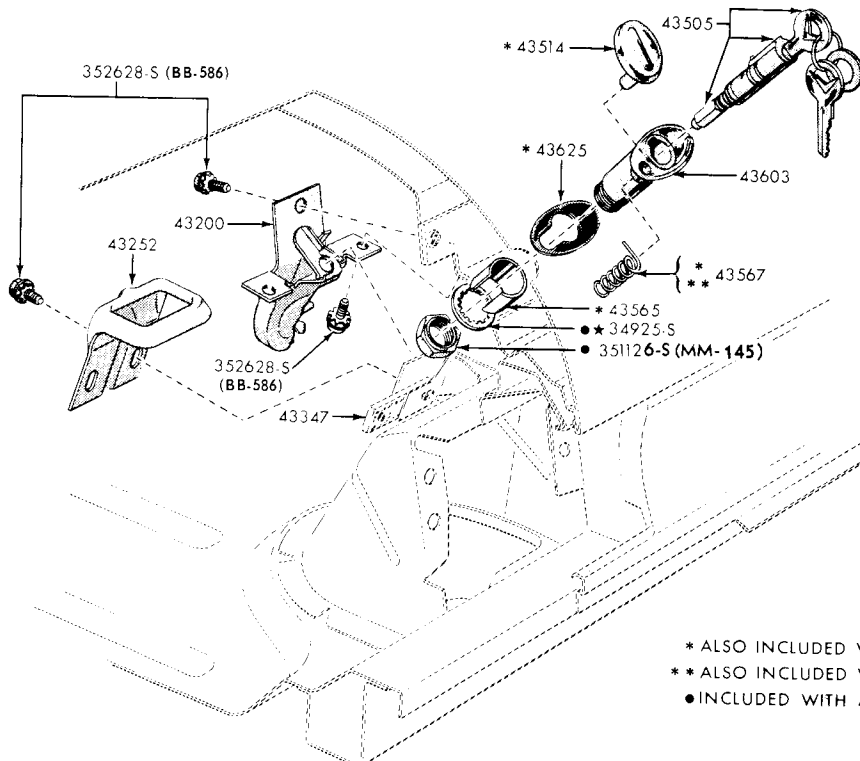

P-3791

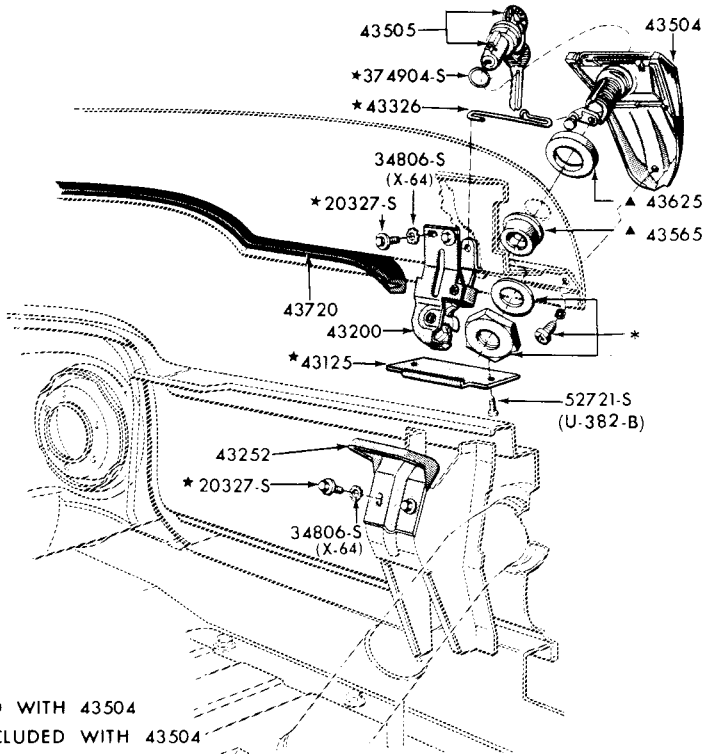

* INCLUDED WITH 43504
▲ ALSO INCLUDED WITH 43504

P-4043

1962/63 FALCON LUGGAGE COMPARTMENT DOOR LOCK & RELATED PARTS - BODY TYPES X(except 59, 66, 71, 78)

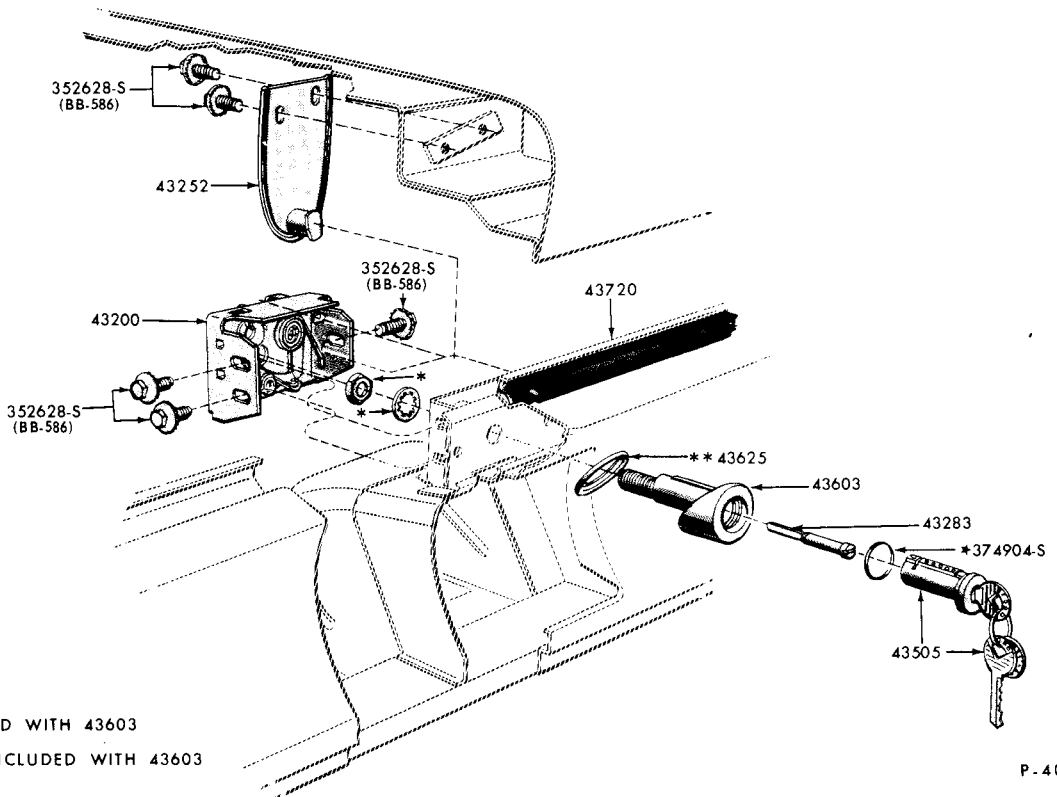

* INCLUDED WITH 43603
** ALSO INCLUDED WITH 43603

P-4042

1963 LUGGAGE COMPARTMENT DOOR LOCK & RELATED PARTS - BODY TYPES A (except 71)

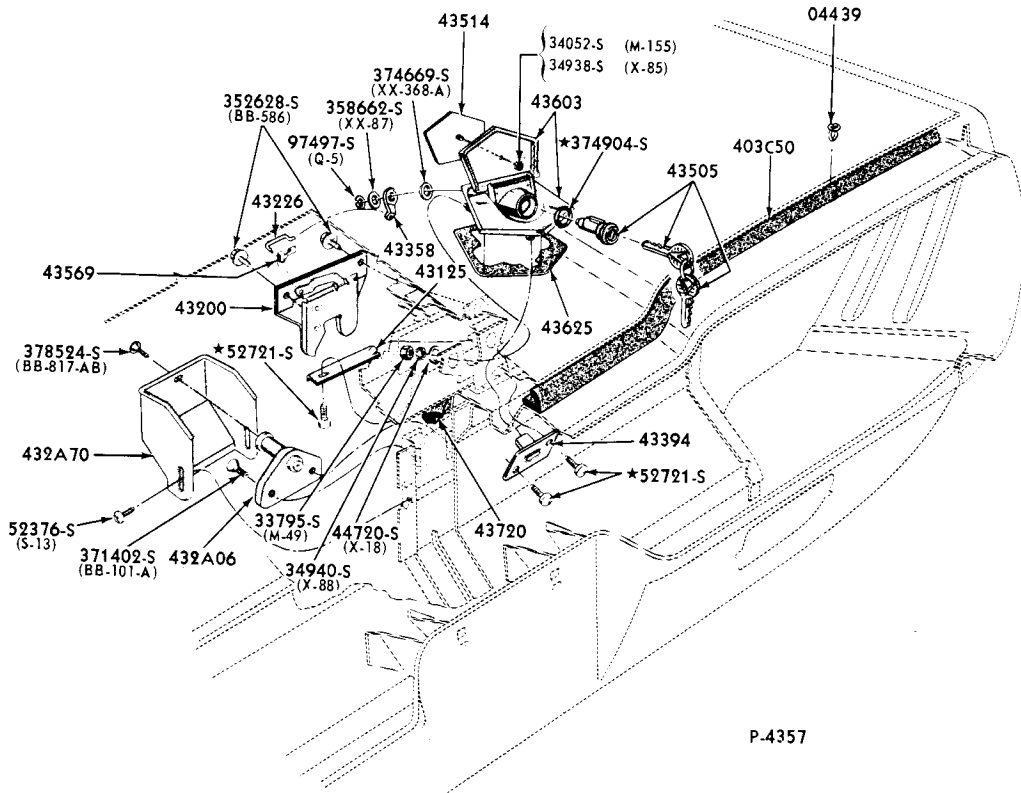

P-4357

1964/ THUNDERBIRD HARD TOP LUGGAGE COMPARTMENT DOOR LOCK & RELATED PARTS - BODY TYPE S(63)

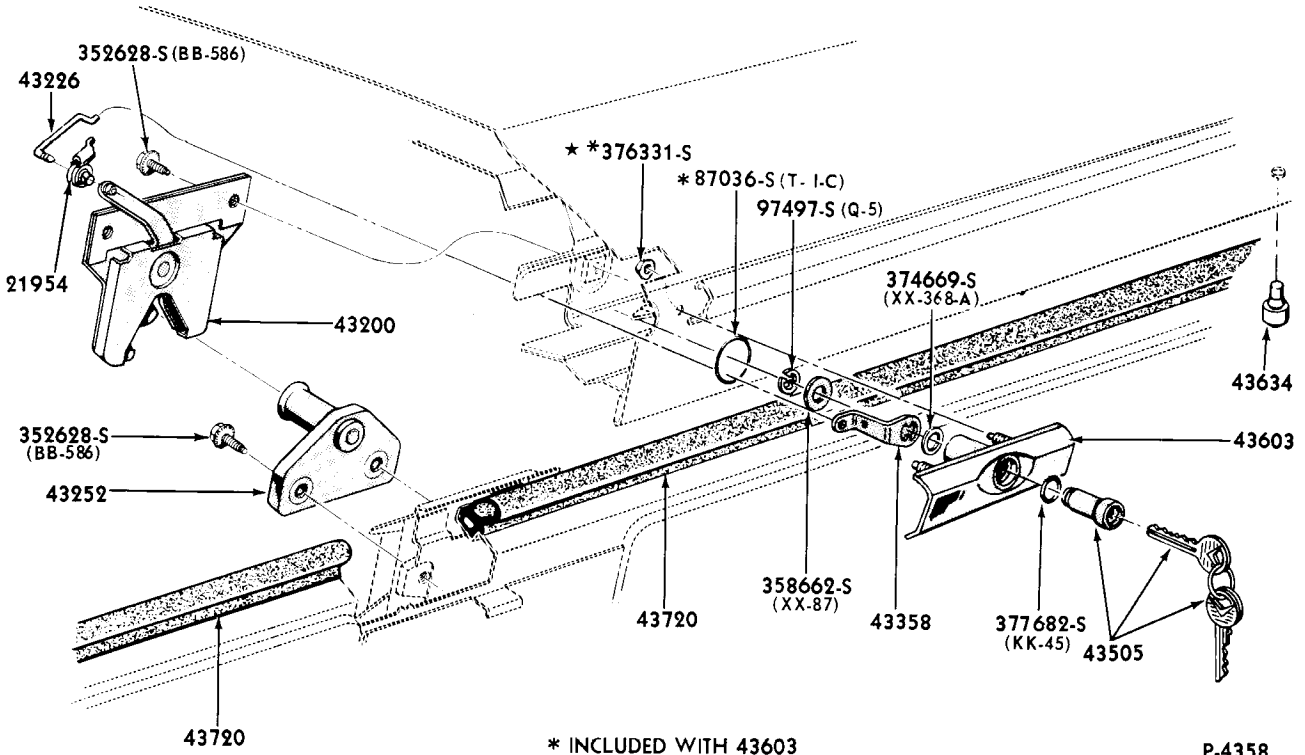

* INCLUDED WITH 43603

P-4358

1964 LUGGAGE COMPARTMENT DOOR LOCK & RELATED PARTS - BODY TYPES A(EXCEPT 71)

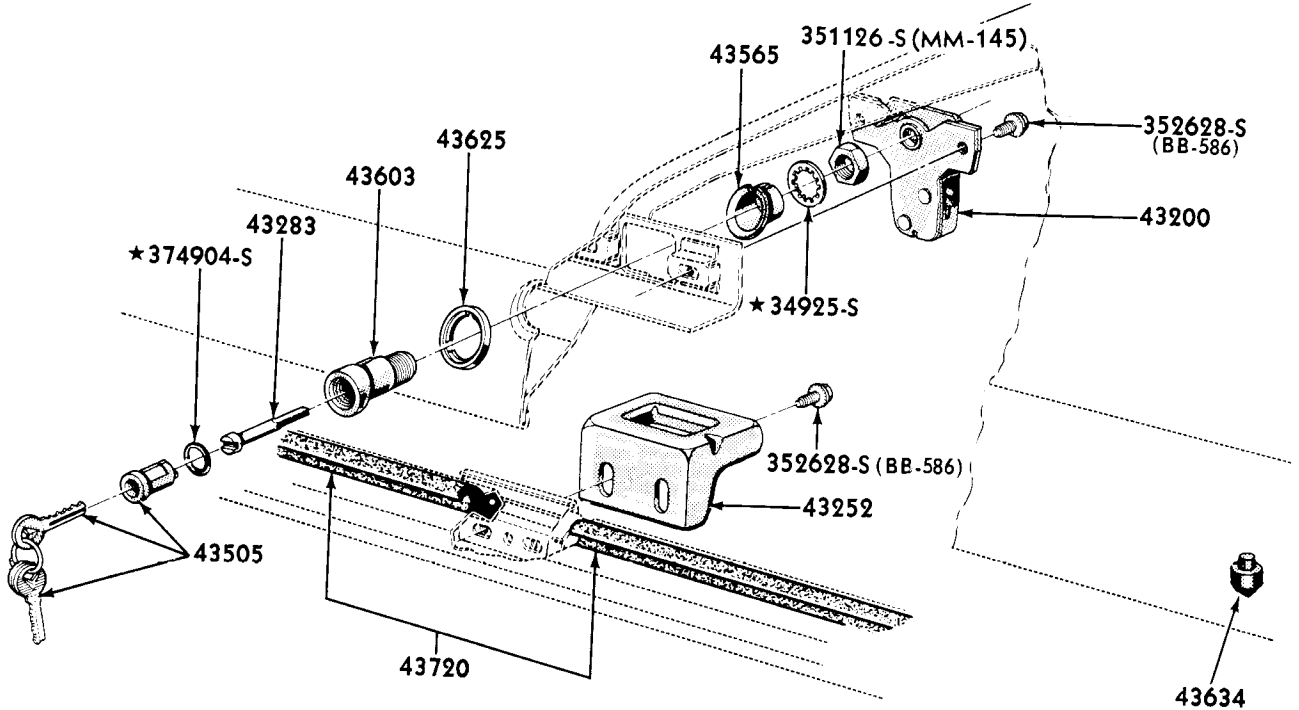

P-4359

1964/ FAIRLANE LUGGAGE COMPARTMENT DOOR LOCK & RELATED PARTS-BODY TYPES B(except 71)- TYPICAL

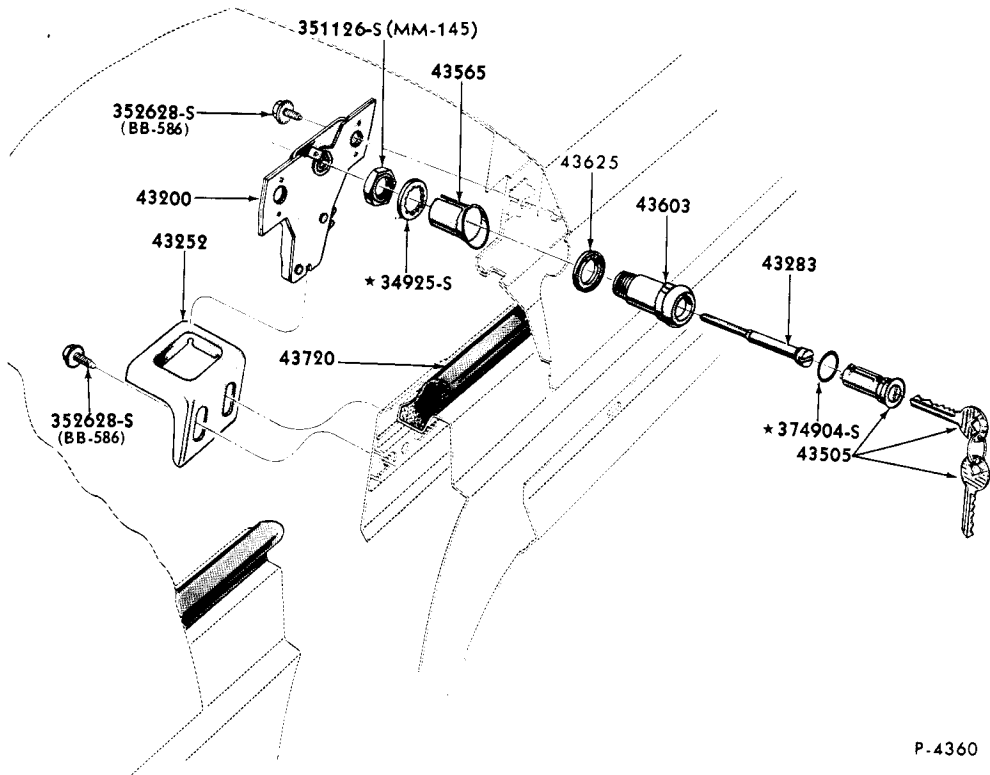

P-4360

1964/ FALCON LUGGAGE COMPARTMENT DOOR LOCK & RELATED PARTS - BODY TYPES X(54, 62, 63, 76)

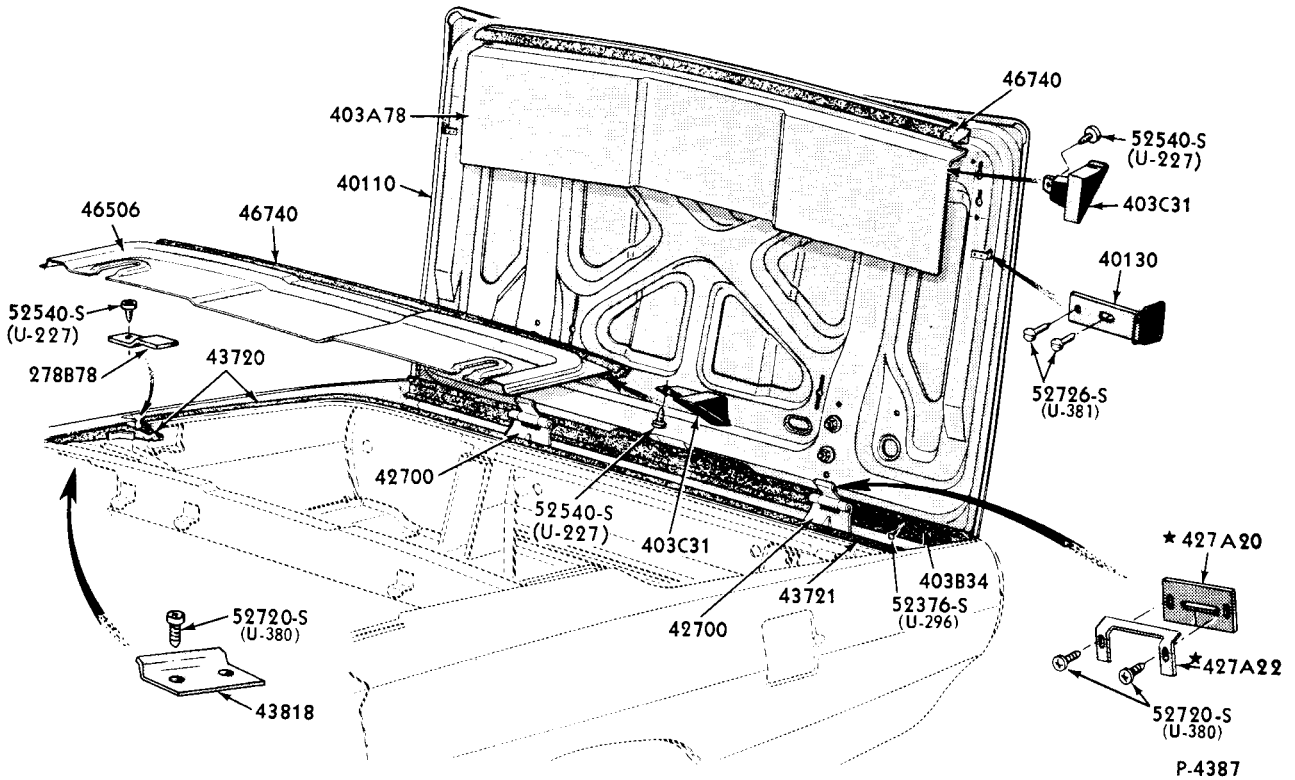

LUGGAGE COMPARTMENT DOOR WEATHERSTRIPS & RELATED PARTS
1964/ THUNDERBIRD-BODY TYPE S(76)

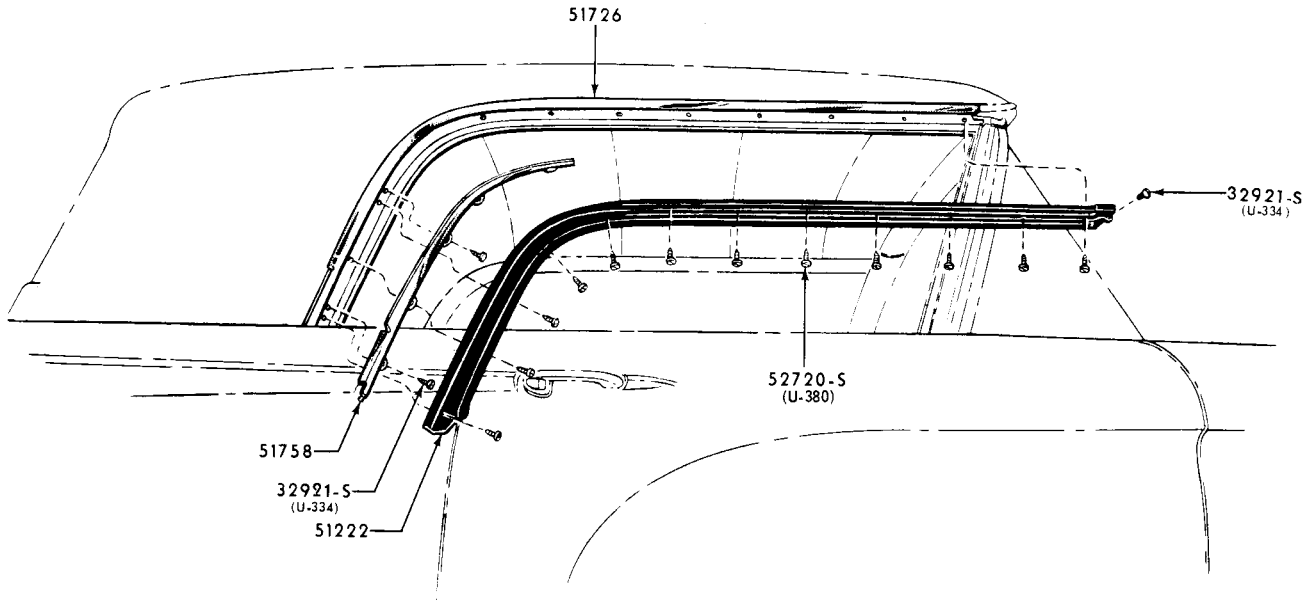

P-2622

1960 THUNDERBIRD ROOF SIDE RAIL WEATHERSTRIP & RELATED PARTS-BODY TYPE 63

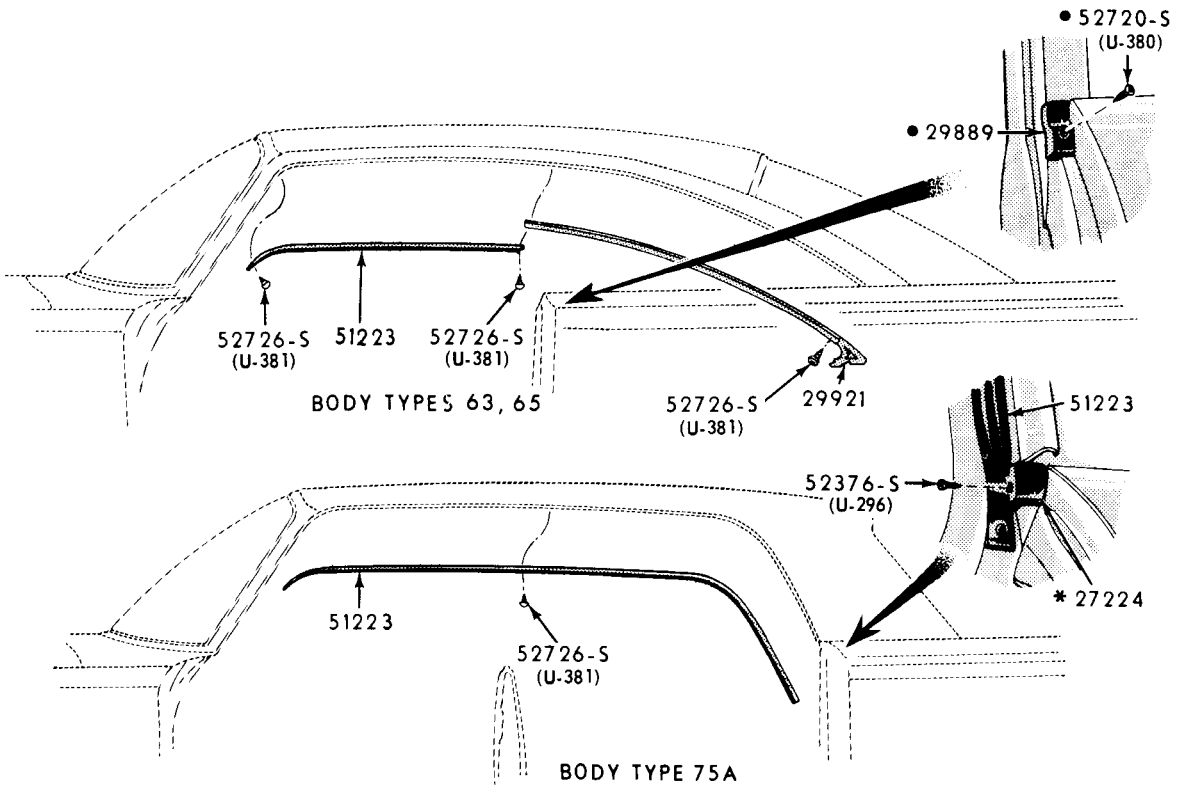

* ALSO USED ON BODY TYPES 54, 58, 71

P-3038

● USED ON BODY TYPES 59, 62, 64, 65, 76 ONLY

ROOF SIDE WEATHERSTRIPS and RELATED PARTS
1960/63 FORD-TYPICAL

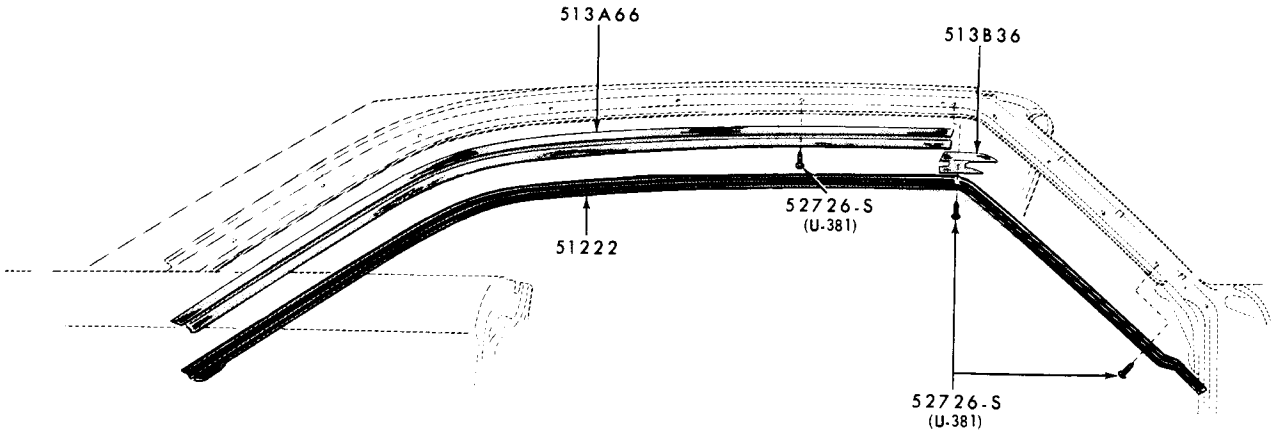

P-4091

ROOF SIDE WEATHERSTRIP and RELATED PARTS
1963/64 FALCON-BODY TYPE 63

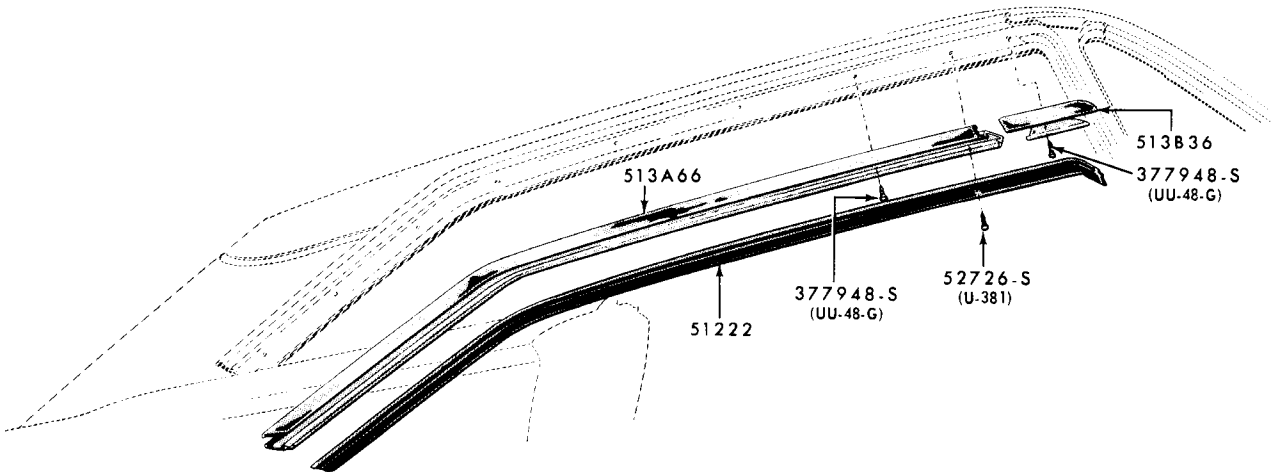

P-3957

ROOF SIDE WEATHERSTRIP and RELATED PARTS
1963/64 FORD-BODY TYPES 57,63

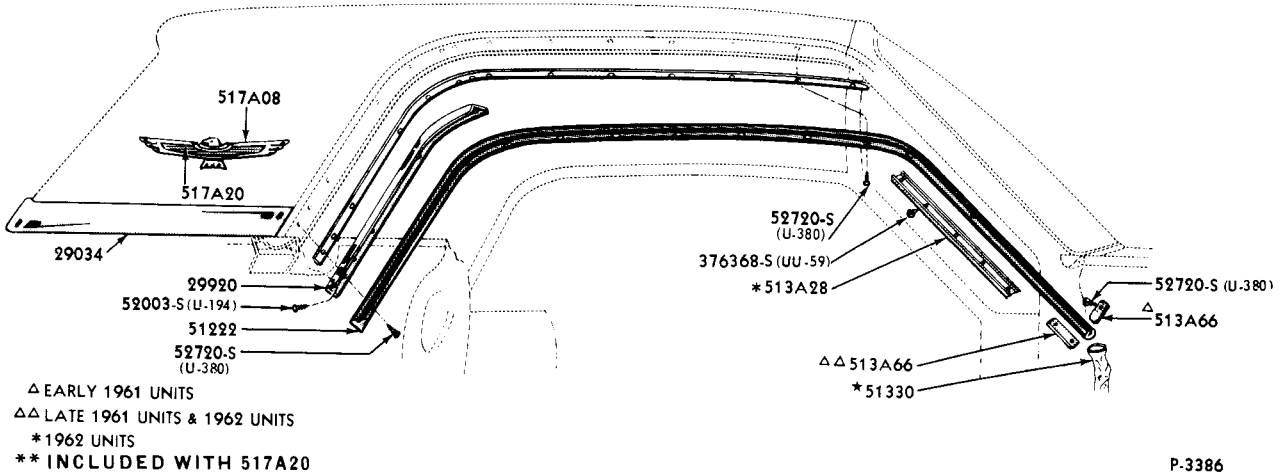
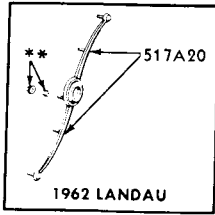

P-3386

1961/63 THUNDERBIRD ROOF SIDE RAIL WEATHERSTRIPS & RELATED PARTS- BODY TYPE 63

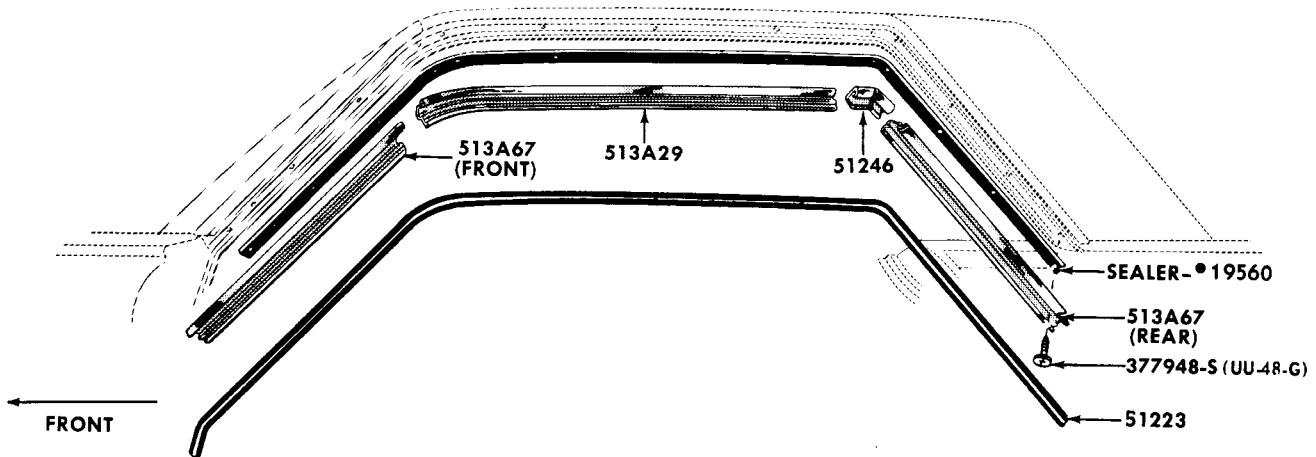

● REFER TO CHASSIS SECTION

P-4354

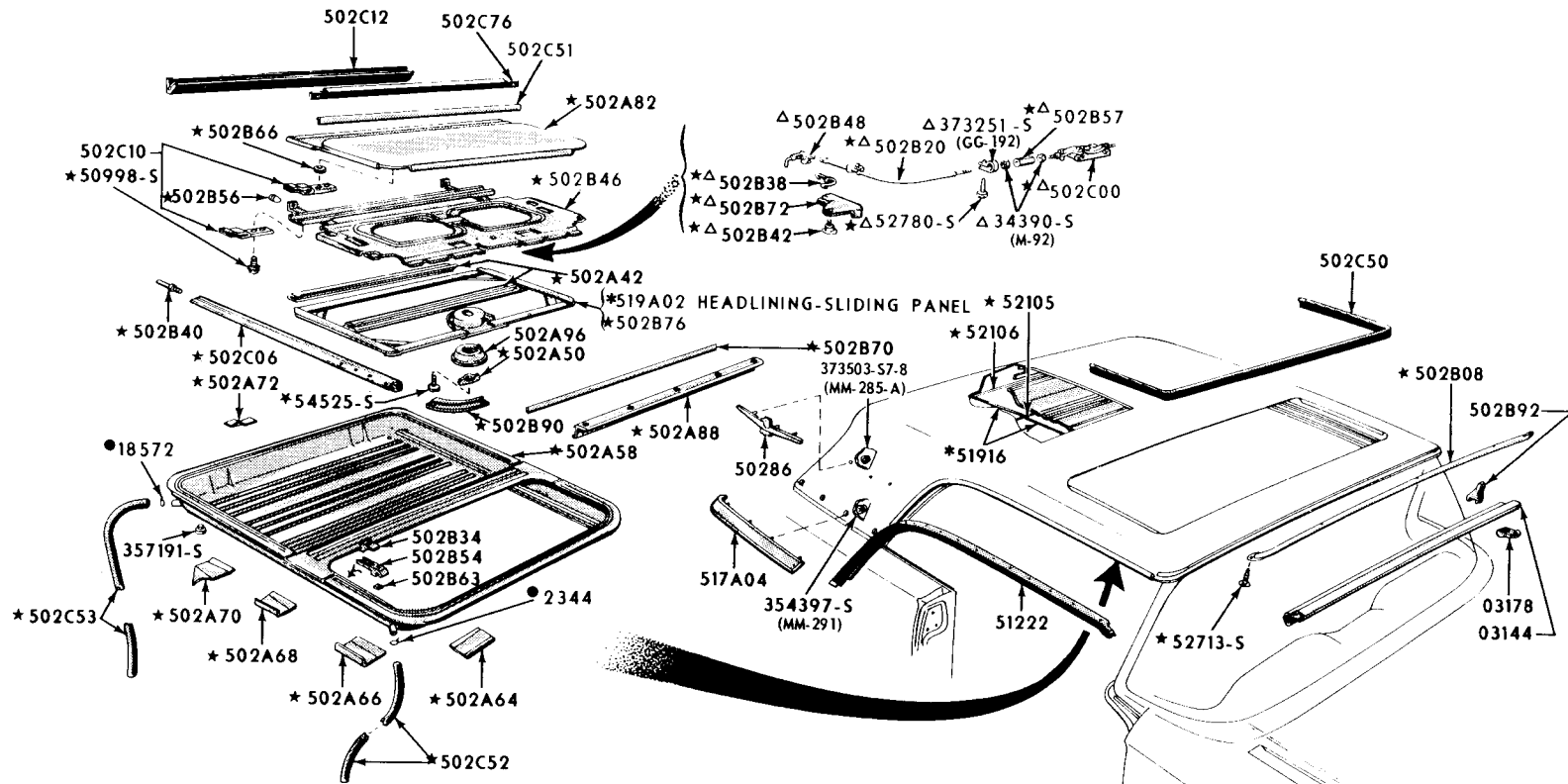

* REFER TO GROUP IN SOFT TRIM SECTION
 Δ ALSO INCLUDED IN 502B46
 ● REFER TO GROUP IN CHASSIS SECTION

P-3164

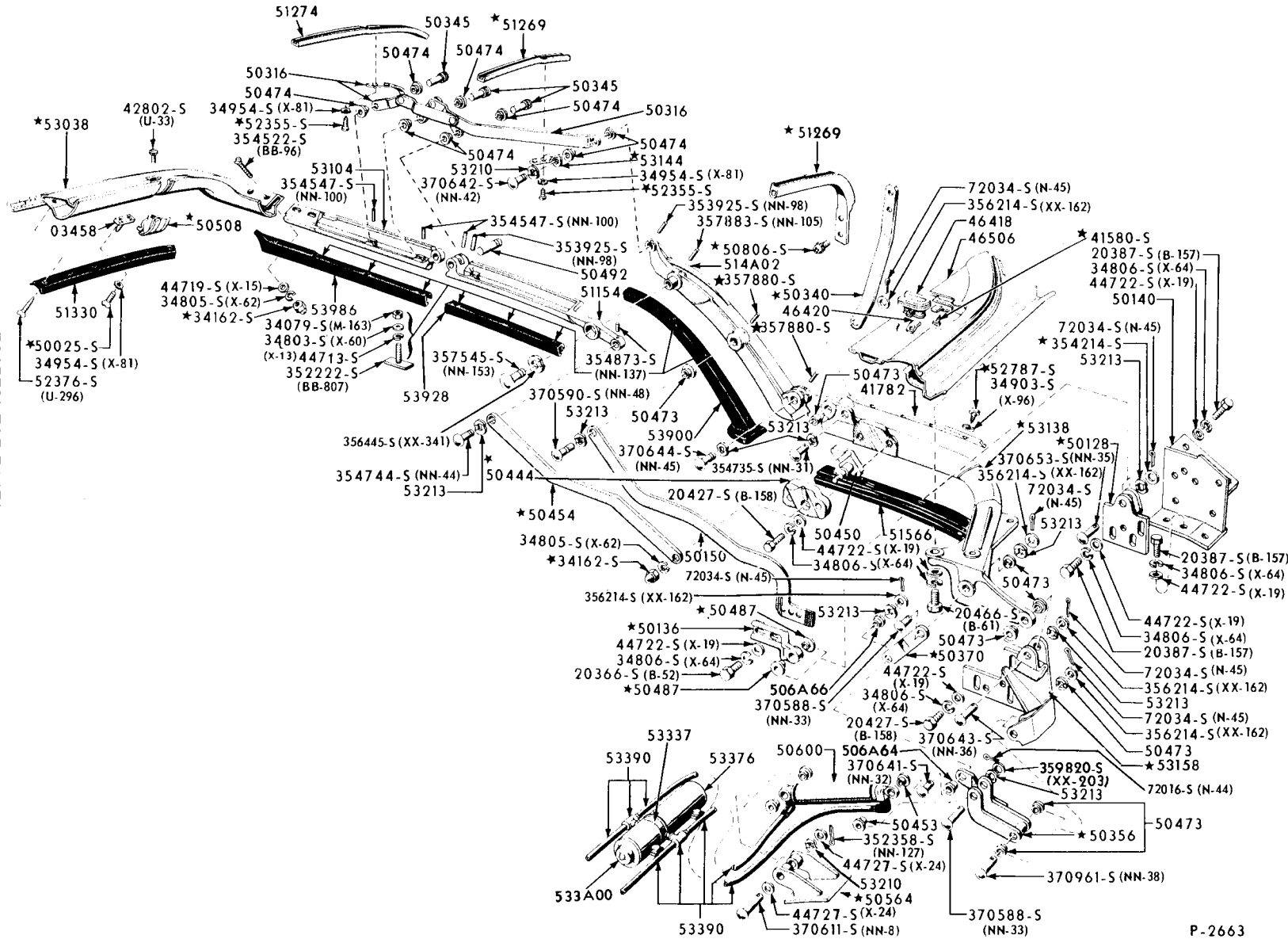

FOLDING TOP PARTS-LESS TRIM
1960 THUNDERBIRD-BODY TYPE 76

1960/64 FORD, FALCON, FALCON and THUNDERBIRD-BODY TYPE 76

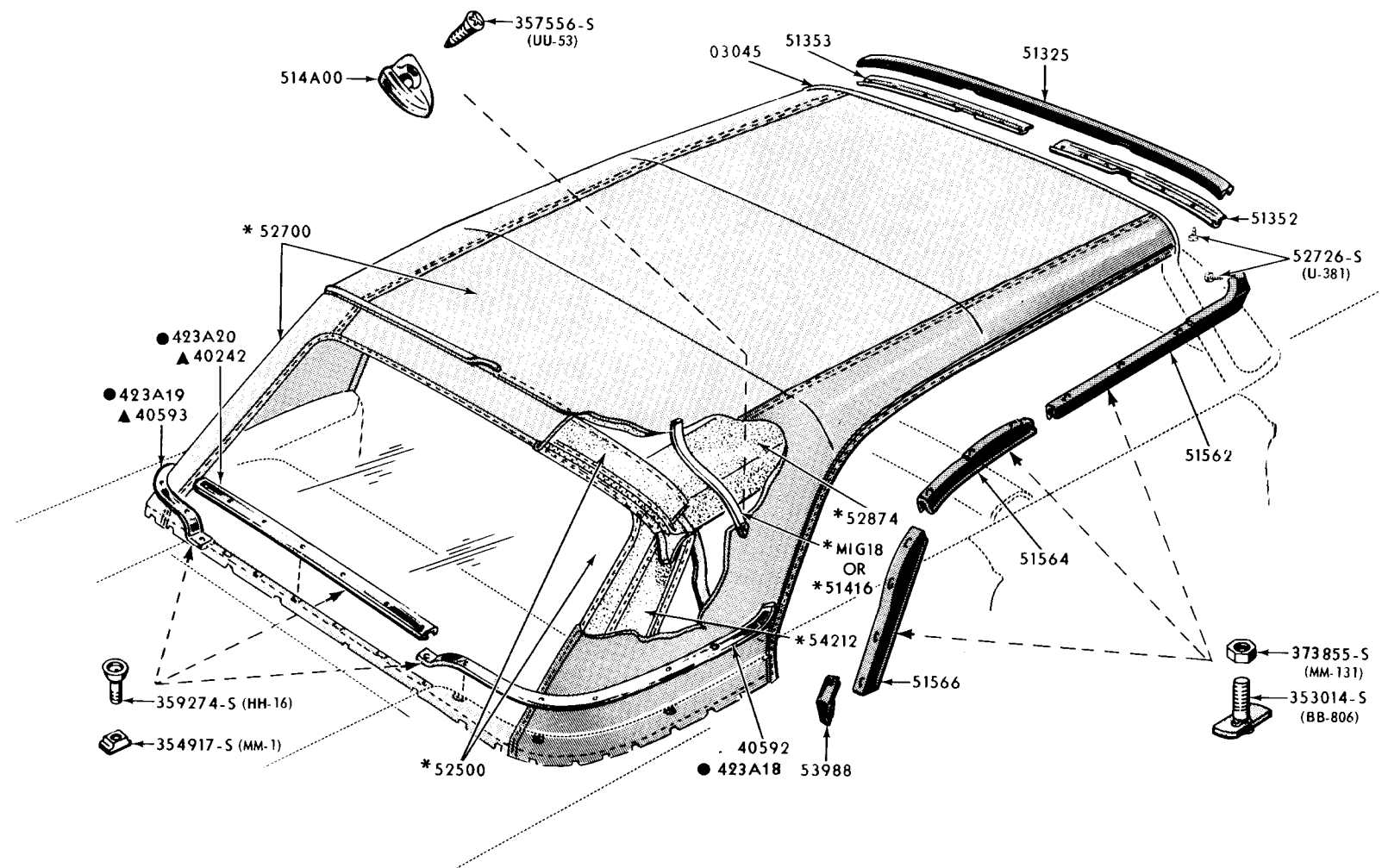

*REFER TO SOFT TRIM SECTION
 ▲1960
 ●1961

1968 / FALCON-BODY TYPE 76

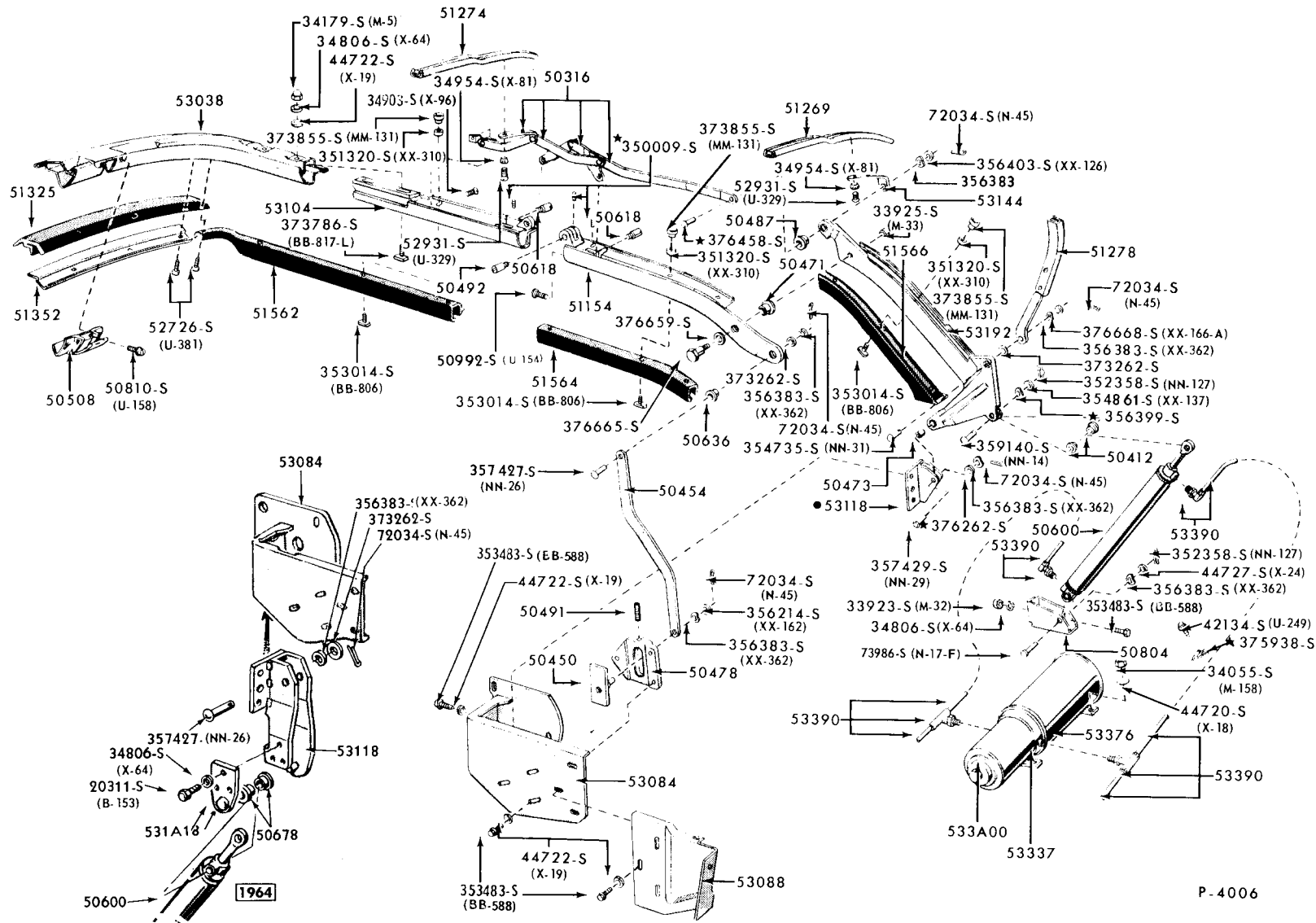

•1963 UNITS

P-4006

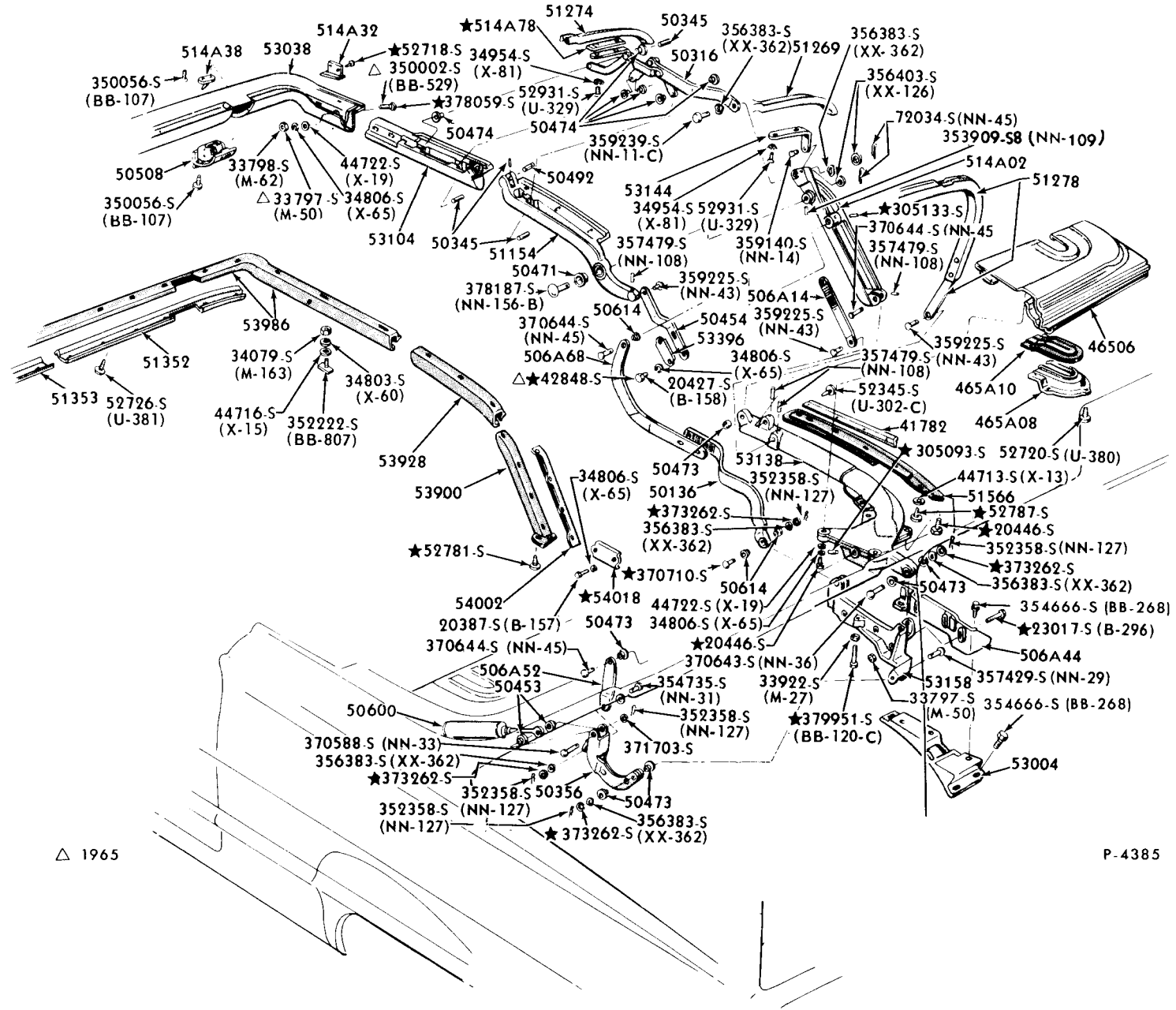

FOLDING TOP PARTS-LESS TRIM
1964/THUNDERBIRD-BODY TYPE 76

△ 1965

P-4385

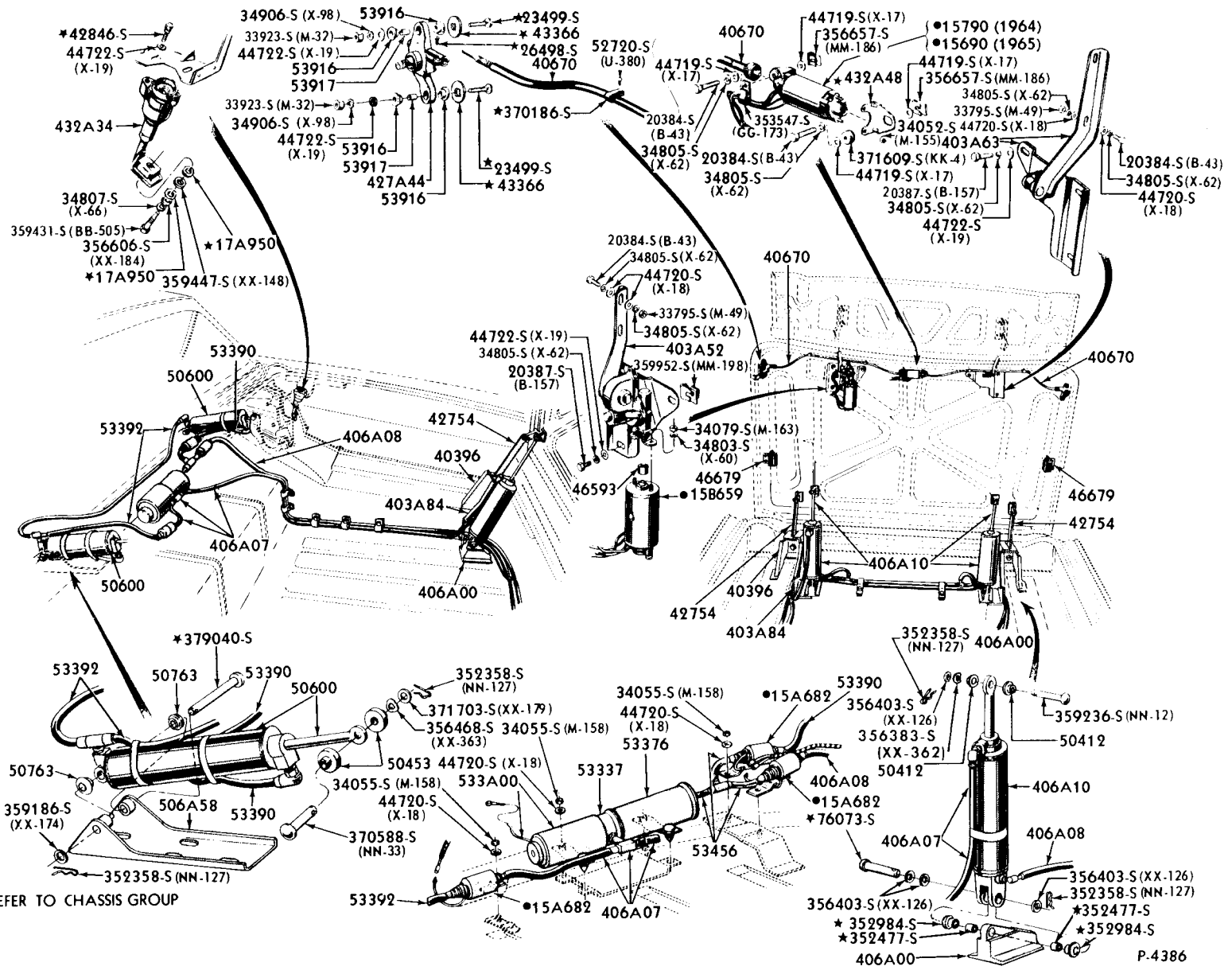

FOLDING TOP and DECK LID HYDRAULIC LIFT and RELATED PARTS
1964/ THUNDERBIRD - BODY TYPE 76

● REFER TO CHASSIS GROUP

P.4386

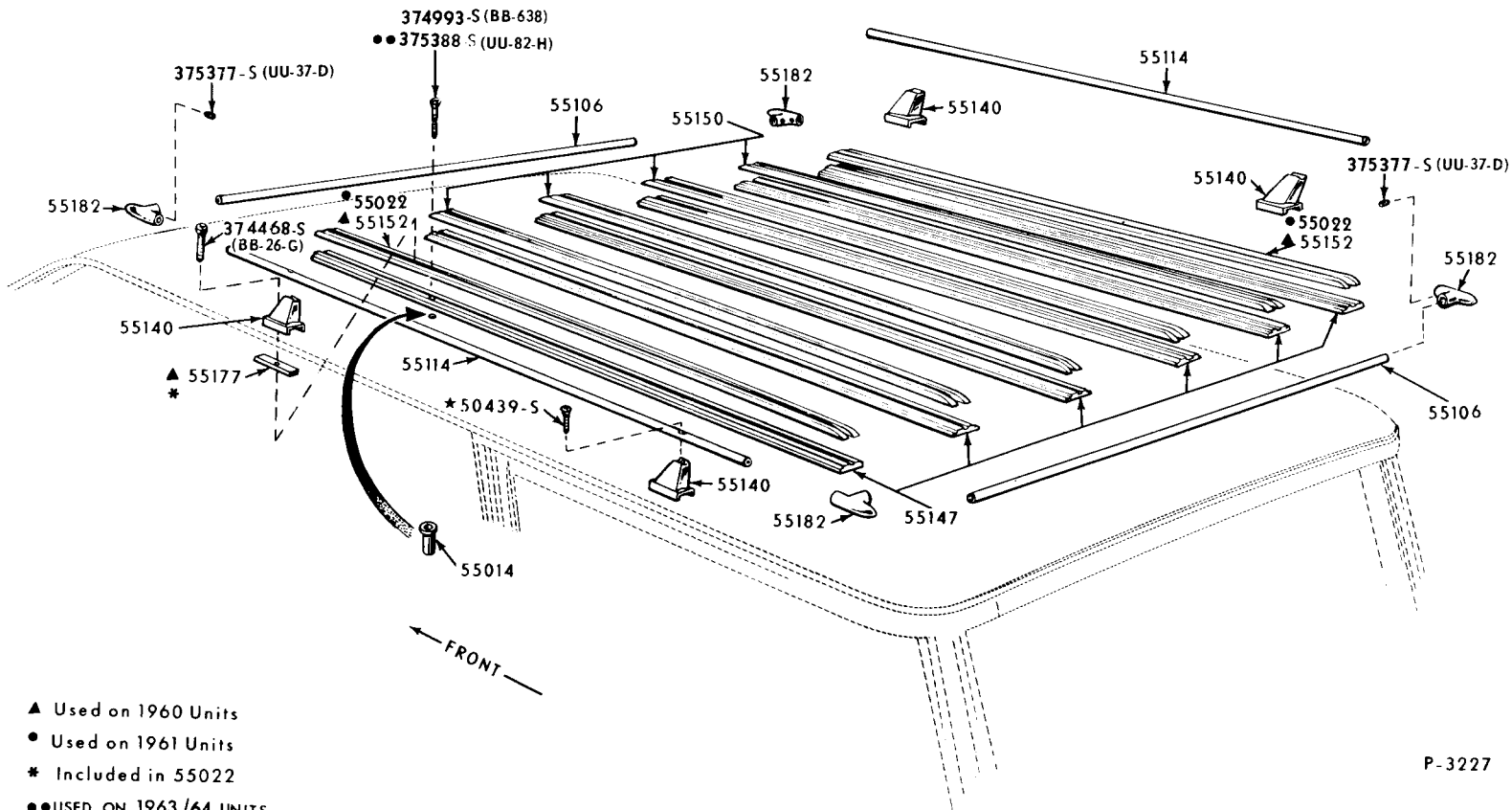

- ▲ Used on 1960 Units
- Used on 1961 Units
- * Included in 55022
- USED ON 1963/64 UNITS

P-3227

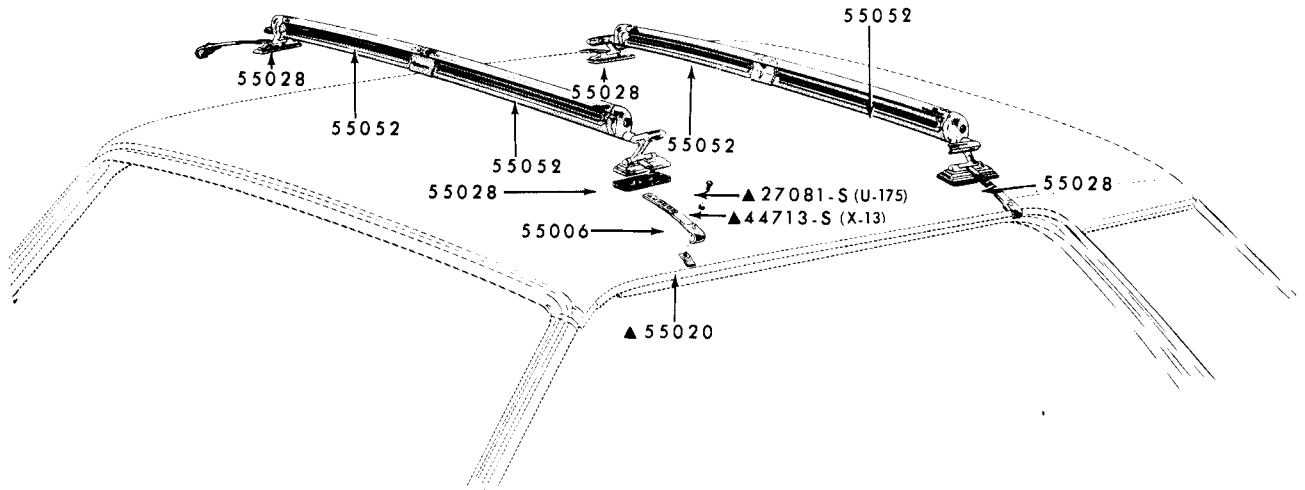

▲ALSO INCLUDED IN 55006

P-4050

ROOF SKI CARRIER
1963/ FORD, FAIRLANE, FALCON and THUNDERBIRD

