

INDEX

INCLUDED IN THIS INDEX ARE THE FOLLOWING MAJOR GROUPS IN THE ORDER SHOWN BELOW:

YEAR	FRONT DOOR	REAR DOOR	QUARTER	ILLUS. NO.	SECTION	PAGE
FRONT DOOR						
FAIRLANE						
1962/64	Front Door Parts-Body Types 54, 62, 71-Typical - "Before 3/1/64"			P-3762	230	628
1963/	Front Door Parts-Body Type 65-Typical			P-4031	230	634
1964/	Front Door Parts-Body Types 54, 62, 71 - "From 3/1/64"			P-4857	230	637
1960/	Front Door Hinge-Upper			P-6980	230	643
1960/	Front Door Hinge-Lower			P-6981	230	642
FALCON						
1960/63	Front Door Parts-Body Types 54, 58, 71-Typical			P-3157	230	617
1960/63	Front Door Parts-Body Types 59, 62, 64, 66, 78A-Typical			P-3158	230	618
1963/	Front Door Parts-Body Types 63, 76 -Typical			P-4035	230	636
1964/	Front Door Parts-except Body Types 63, 76 - Typical			P-4339	230	641
1960/	Front Door Hinge-Upper			P-6980	230	643
1960/	Front Door Hinge-Lower			P-6981	230	642
FORD						
	Door Bumpers - Rubber			P-3588	230	644
1960	Front Door Outside Handle, Lock, & Related Parts			P-3026	230	615
1961	Front Door Outside Handle, Lock & Related Parts			P-3342	230	619
1962	Front Door Outside Handle, Lock & Related Parts			P-3785	230	627
1963/64	Front Door Outside Handle, Lock & Related Parts -Typical			P-4029	230	633
1960	Front Door Ventilating Window Handles, Upper Pivot & Brackets - except Body Types 63, 75, 76			P-3232	230	613
1960/	Front Door Hinge-Upper			P-6980	230	643
1960/	Front Door Hinge-Lower			P-6981	230	642
1960/61	Front Door Ventilating Window Parts - Typical			P-3025	230	614
1960/61	Front Door Ventilating Window Parts - Typical - Body Types 63, 65, 76			P-3095	230	614
1960/61	Front Door Ventilating Window Parts - Typical-Body Type 75			P-3096	230	614
1960/61	Front Door Window Parts - Body Types 54, 58, 71			P-3022	230	609
1960/61	Front Door Window Parts - Body Types -59, 62, 64			P-3021	230	610
1960/61	Front Door Window Parts - Body Types 63, 65, 76			P-3023	230	611
1960/61	Front Door Window Parts - Body Type 75			P-3024	230	612
1962	Front Door Window Parts - Body Types 54, 71			P-3781	230	622
1962	Front Door Window Parts-Body Type 62			P-3782	230	623
1962	Front Door Window Parts-Body Type 65			P-3783	230	624
1962	Front Door Window Parts - Body Type 75			P-3784	230	625
1962	Front Door Window Parts-Body Type 76			P-3793	230	626
1963/64	Front Door Window & Related Parts -Body Types 54, 71-Typical			P-4023	230	629
1963/64	Front Door Window & Related Parts-Body Types 57, 75			P-4026	230	632
1963/64	Front Door Window & Related Parts -Body Type 62			P-4024	230	630
1963/64	Front Door Window & Related Parts -Body Types 63, 65, 76 -Typical			P-4025	230	631
THUNDERBIRD						
1960	Door Parts			P-2617	230	616
1960/	Front Door Hinge-Upper			P-6980	230	643
1960/	Front Door Hinge-Lower			P-6981	230	642
1961/63	Front Door Lock & Related Parts			P-3357	230	621
1964	Front Door Lock & Related Parts			P-4341	230	639
1964	Front Door Window & Related Parts-Typical			P-4340	230	638
1961/63	Front Door Window Parts			P-3356	230	620
1964/	Vacuum Door Lock & Related Parts			P-4902	230	640
1963	Vacuum Door Lock Assy. & Related Parts			P-4049	230	635

INDEX

YEAR	TITLE	ILLUS. NO.	SECTION	PAGE
REAR DOOR				
FAIRLANE				
1962/	Rear Door Parts-Body Types 54, 71-Typical	P-3763	240	654
1960/	Rear Door Hinge-Upper	P-6982	240	661
1960/	Rear Door Hinge-Lower	P-6983	240	661
FALCON				
1960/63	Rear Door Parts-Body Types 54, 58-Typical	P-3159	240	649
1960/63	Rear Door Parts-Body Type 71-Typical	P-3168	240	650
1964/	Rear Door Parts-Body Type 54-Typical	P-4342	240	659
1964/	Rear Door Parts-Body Type 71-Typical	P-4343	240	660
1960/	Rear Door Hinge-Upper	P-6982	240	661
1960/	Rear Door Hinge-Lower	P-6983	240	661
FORD				
1960	Rear Door Outside Handle, Lock & Related Parts-Body Types 54, 58, 71	P-3029	240	647
1961	Rear Door Outside Handle, Lock & Related Parts-Body Types 54, 58, 71	P-3343	240	648
1962	Rear Door Outside Handle, Lock & Related Parts-Body Types 54, 58, 71, 75	P-3788	240	653
1963/64	Rear Door Outside Handle, Lock & Related Parts-Body Types 54, 57, 71	P-4030	240	658
1963	Rear Door Window & Related Parts-Body Type 75-Typical	P-4028	240	656
1963/64	Rear Door Window & Related Parts-Body Types 54, 71-Typical	P-4027	240	655
1964	Rear Door Window & Related Parts-Body Type 57	P-4338	240	657
1960/61	Rear Door Window Parts-Body Types 54, 58, 71	P-3027	240	645
1962	Rear Door Window Parts-Body Types 54, 71	P-3786	240	651
1960/61	Rear Door Window Parts-Body Type 75	P-3028	240	646
1962	Rear Door Window Parts-Body Type 75	P-3787	240	652
1960/	Rear Door Hinge-Upper	P-6982	240	661
1960/	Rear Door Hinge-Lower	P-6983	240	661
QUARTER				
FAIRLANE				
1963/	Quarter Window & Related Parts-Body Type 71	P-4033	290	680
1962/	Quarter Window Parts-Body Type 62-Typical	P-3764	290	678
1963/	Quarter Window Parts-Body Type 65-Typical	P-4032	290	679
FALCON				
1960/	Quarter Window & Related Parts-Body Types 59, 62, 64-Typical	P-3160	290	668
1963/	Quarter Window & Related Parts-Body Type 63-Typical	P-3952	290	681
1963/	Quarter Window & Related Parts-Body Type 76	P-4036	290	682
1961/	Sedan Delivery Quarter Window Opening Panel & Related Parts-Body Type 78	P-3593	290	669
FORD				
1960/61	Front Quarter Window Parts-Body Type 59C	P-3033	290	662
1961	Quarter Window & Related Parts-Body Type 65	P-3344	290	670
1962/63	Quarter Window & Related Parts-Body Type 62	P-3789	290	672
1962/63	Quarter Window & Related Parts-Body Type 65-Typical	P-3790	290	676
1963	Quarter Window & Related Parts-Body Type 63	P-3955	290	674
1964	Quarter Window & Related Parts-Body Type 62	P-4345	290	673
1964	Quarter Window & Related Parts-Body Type 63	P-4346	290	675
1960/61	Quarter Window Parts-Body Types 59E, 64G, H	P-3031	290	663
1960/61	Quarter Window Parts-Body Types 62, 64A, F	P-3030	290	664
1960/61	Quarter Window Parts-Body Type 63	P-3034	290	665
1960/61	Quarter Window Parts-Body Type 76-Typical	P-3032	290	666
1962/64	Quarter Window Parts-Body Type 76-Typical	P-3792	290	677
1960	Rear Quarter Window Parts-Body Types 59, 71	P-3035	290	662
1961/64	Rear Quarter Window Parts-Body Types 59, 71-Typical	P-3345	290	669
THUNDERBIRD				
1964/	Quarter Window & Related Parts	P-4344	290	683
1960	Quarter Window Parts	P-2618	290	667
1961/63	Quarter Window Parts	P-3358	290	671

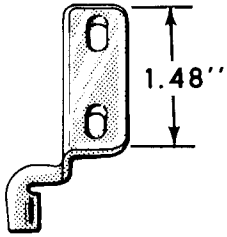

COAB6421464-B

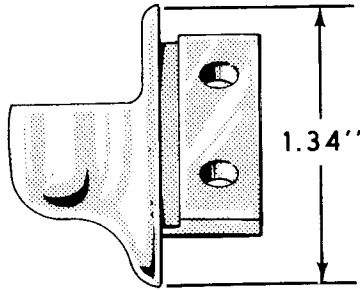

COAB6421466-A

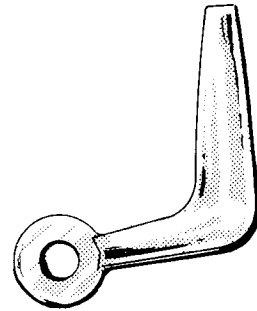

B9A6422916-A

USED ON UNITS MANUFACTURED BEFORE MARCH 15, 1960

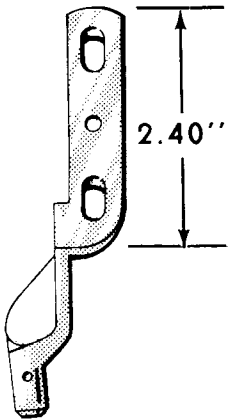

COAB6421464-C

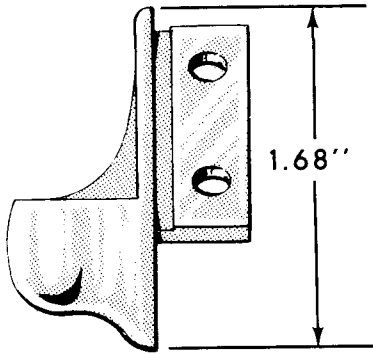

COAB6421466-C

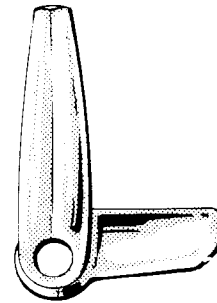

COAB6422916-A

USED ON UNITS MANUFACTURED FROM MARCH 15, 1960

P-3232

FRONT DOOR VENTILATING WINDOW HANDLES, UPPER PIVOT & BRACKETS
(1960 FORD-except BODY TYPES 63,75,76)

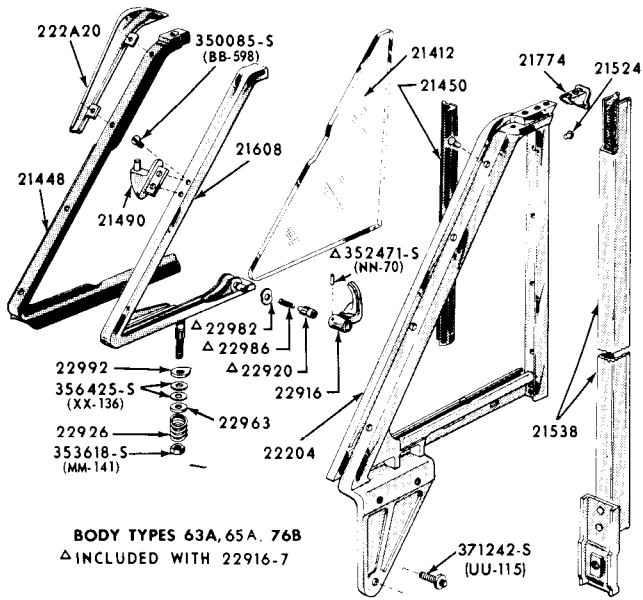

P-3095

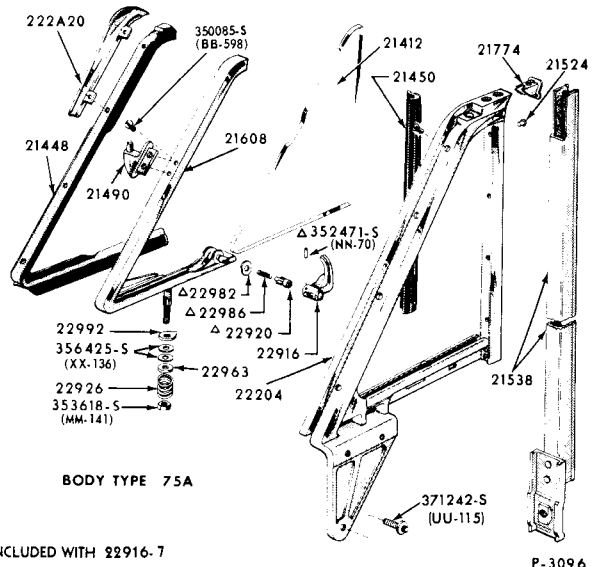

P-3096

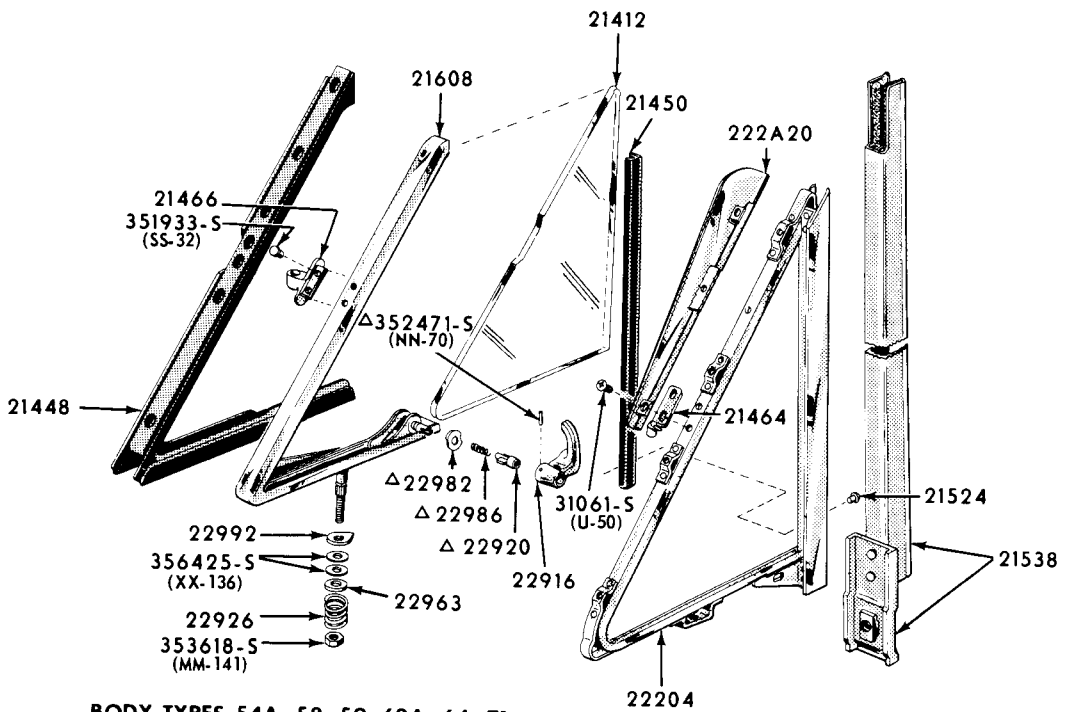

P-3025

1960 FRONT DOOR OUTSIDE HANDLE, LOCK & RELATED PARTS-BODY TYPES A(11)

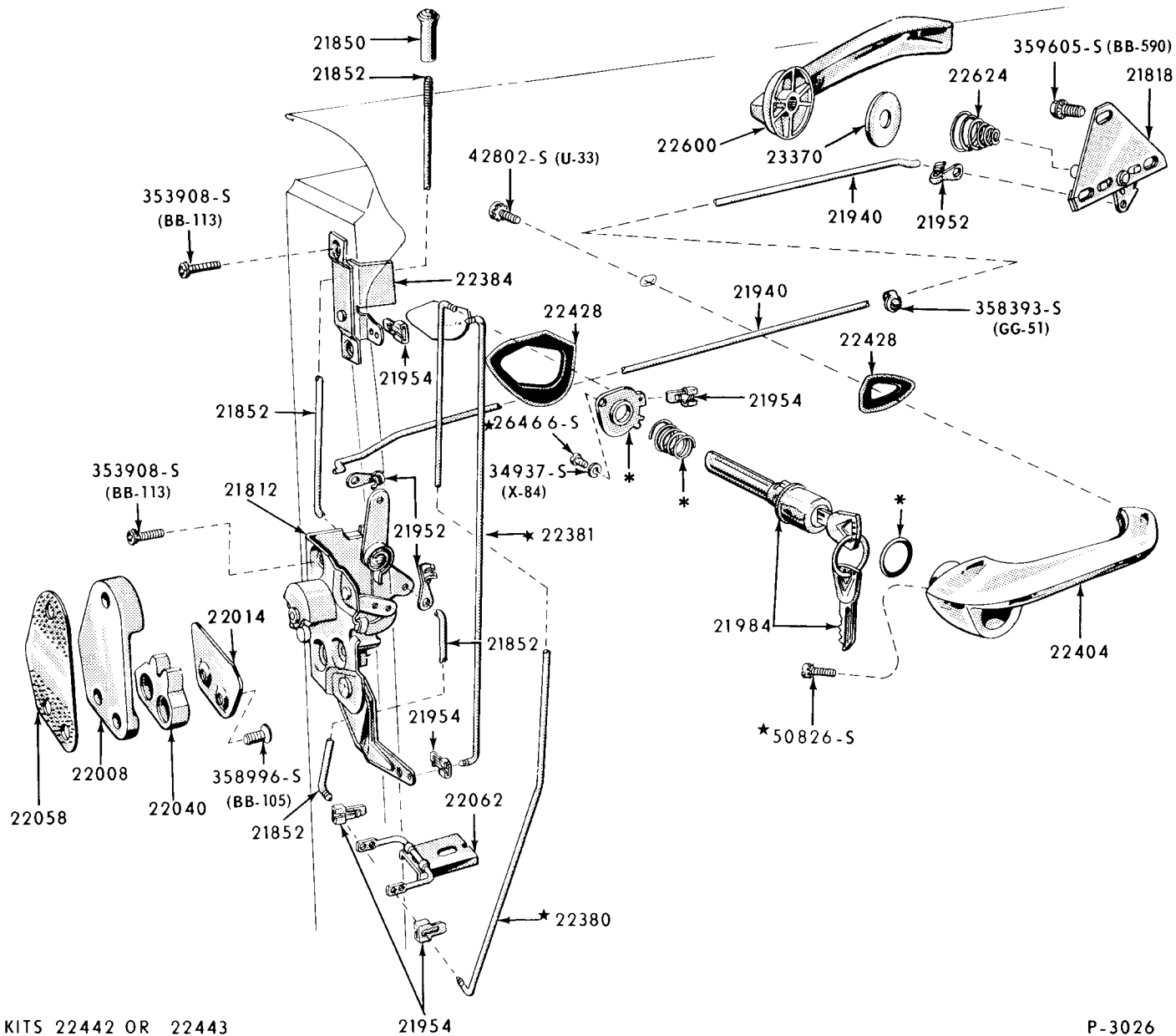

* SERVICED IN KITS 22442 OR 22443

P-3026

FORD CAR PARTS

**BODY ILLUSTRATION
SECTION 230**

615

1960 THUNDERBIRD DOOR PARTS

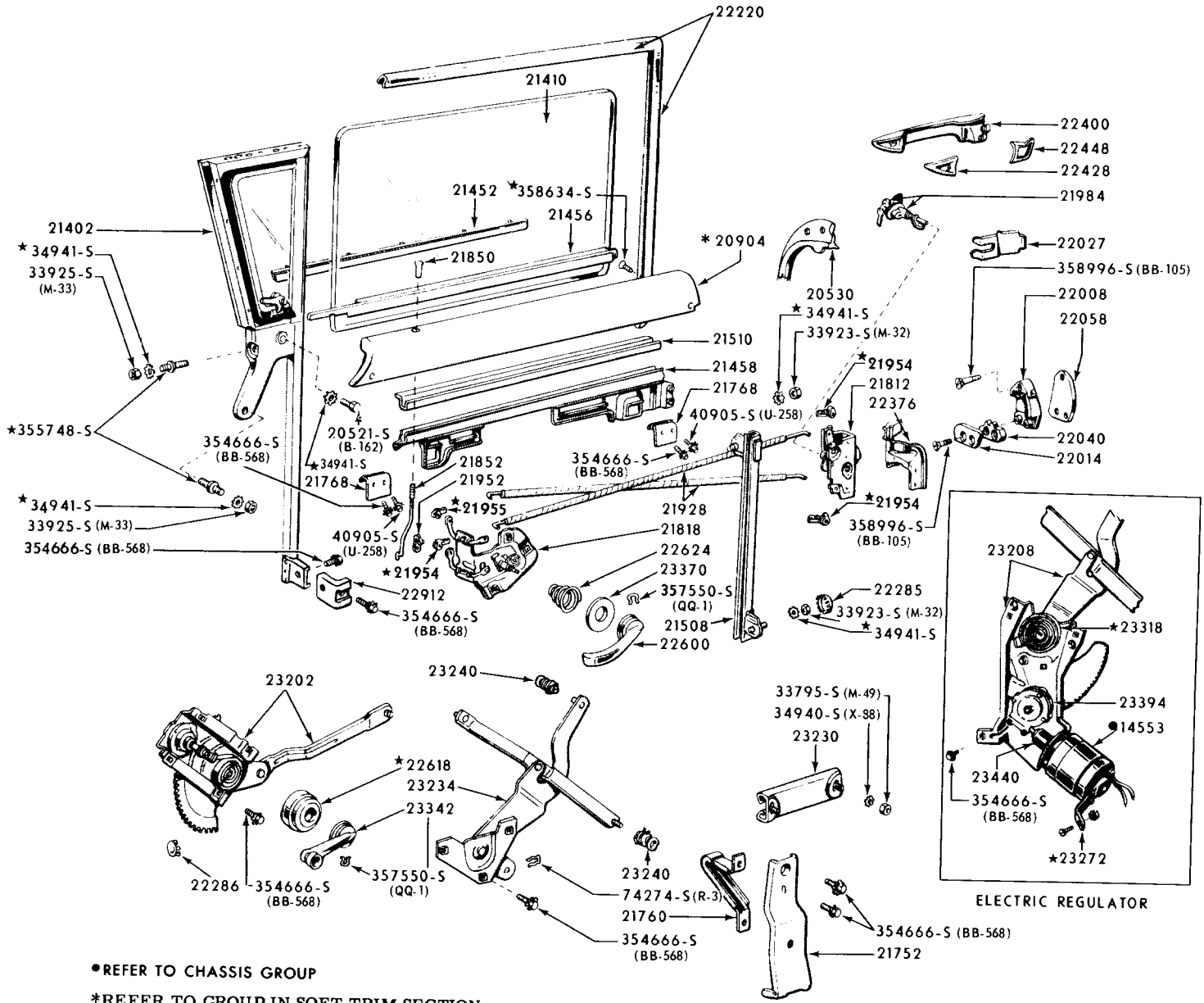

●REFER TO CHASSIS GROUP
 *REFER TO GROUP IN SOFT TRIM SECTION

1960/63 FALCON FRONT DOOR PARTS - BODY TYPES X(59A, 62, 64, 66A, 78A) - TYPICAL

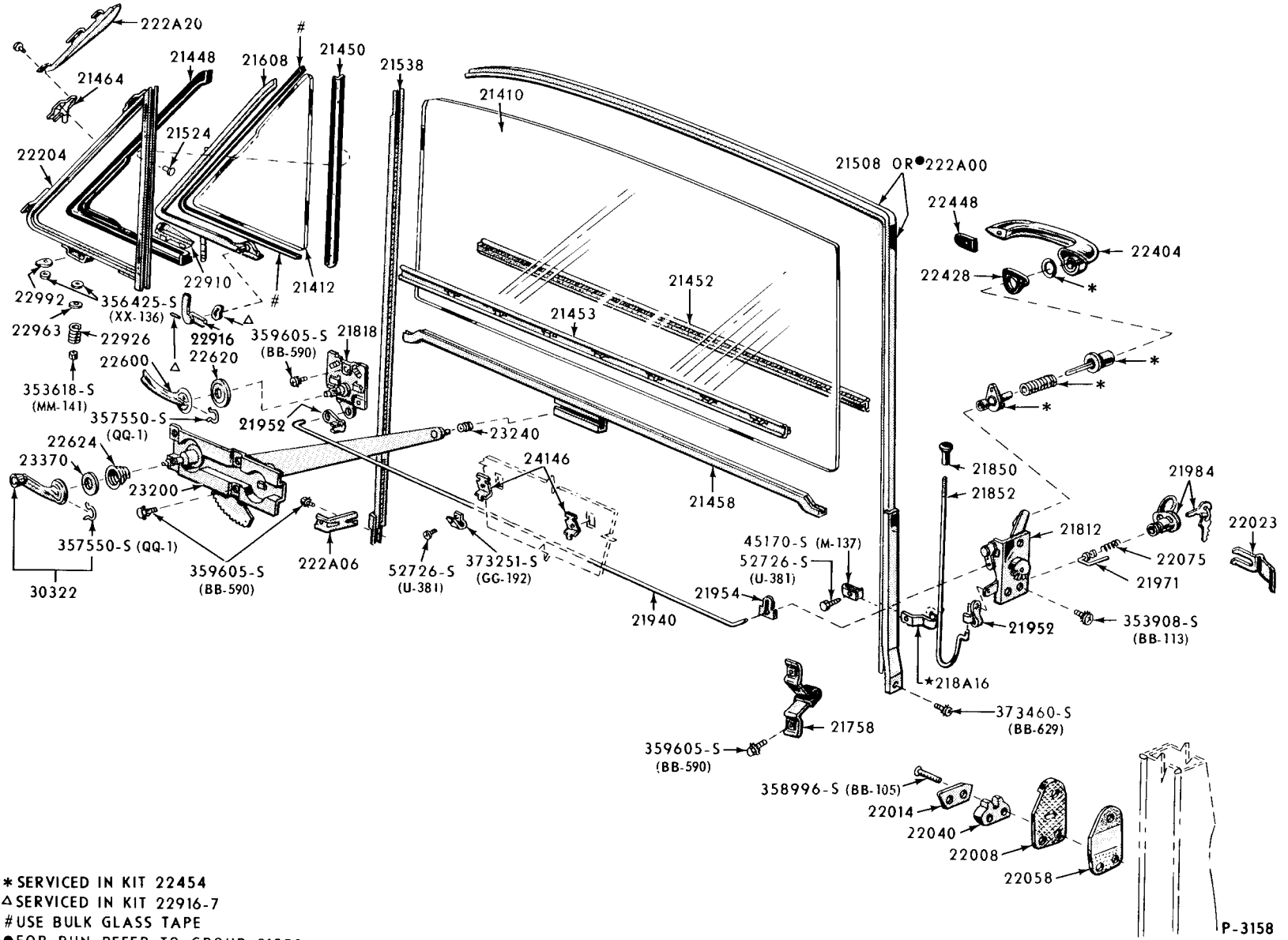

- * SERVICED IN KIT 22454
- Δ SERVICED IN KIT 22916-7
- # USE BULK GLASS TAPE
- FOR RUN REFER TO GROUP 21550

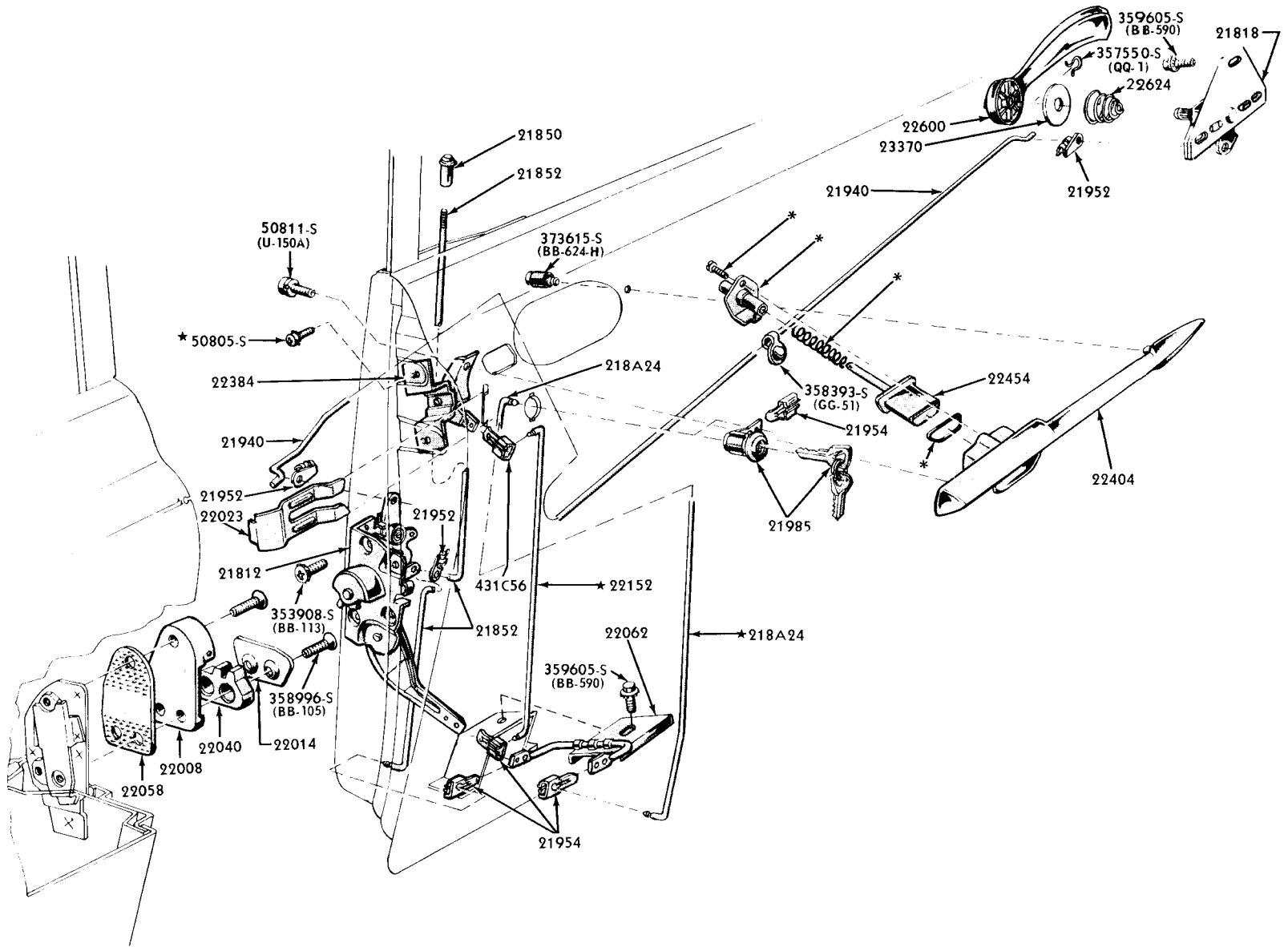

* SERVICED IN KITS 22454 OR 22455

1962 FRONT DOOR WINDOW PARTS-BODY TYPES A(54,71)

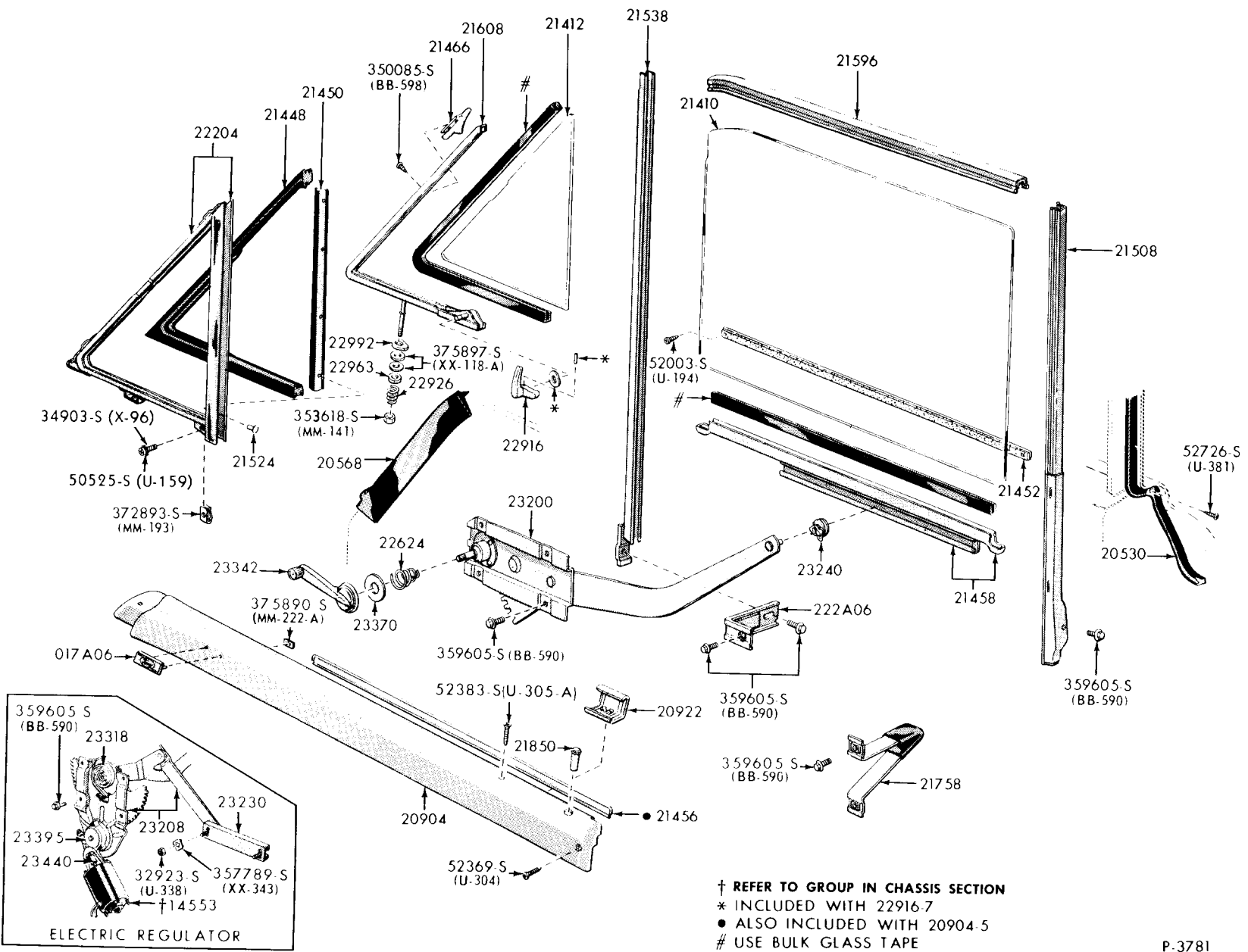

† REFER TO GROUP IN CHASSIS SECTION
 * INCLUDED WITH 22916-7
 ● ALSO INCLUDED WITH 20904-5
 # USE BULK GLASS TAPE

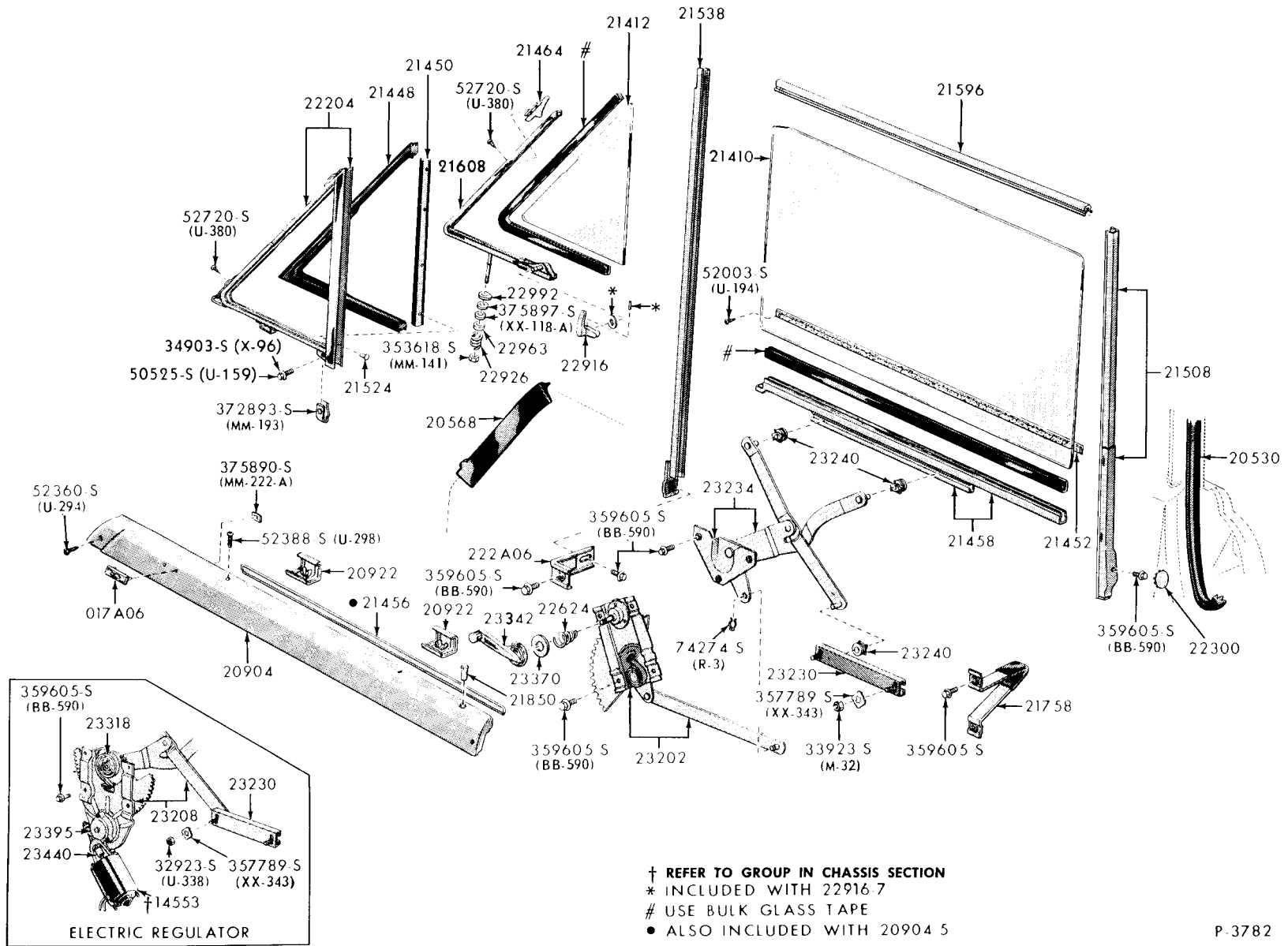

1962 DOOR WINDOW PARTS - BODY TYPE A (65)

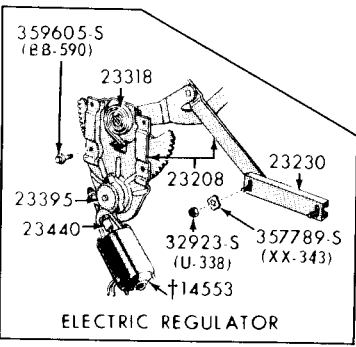
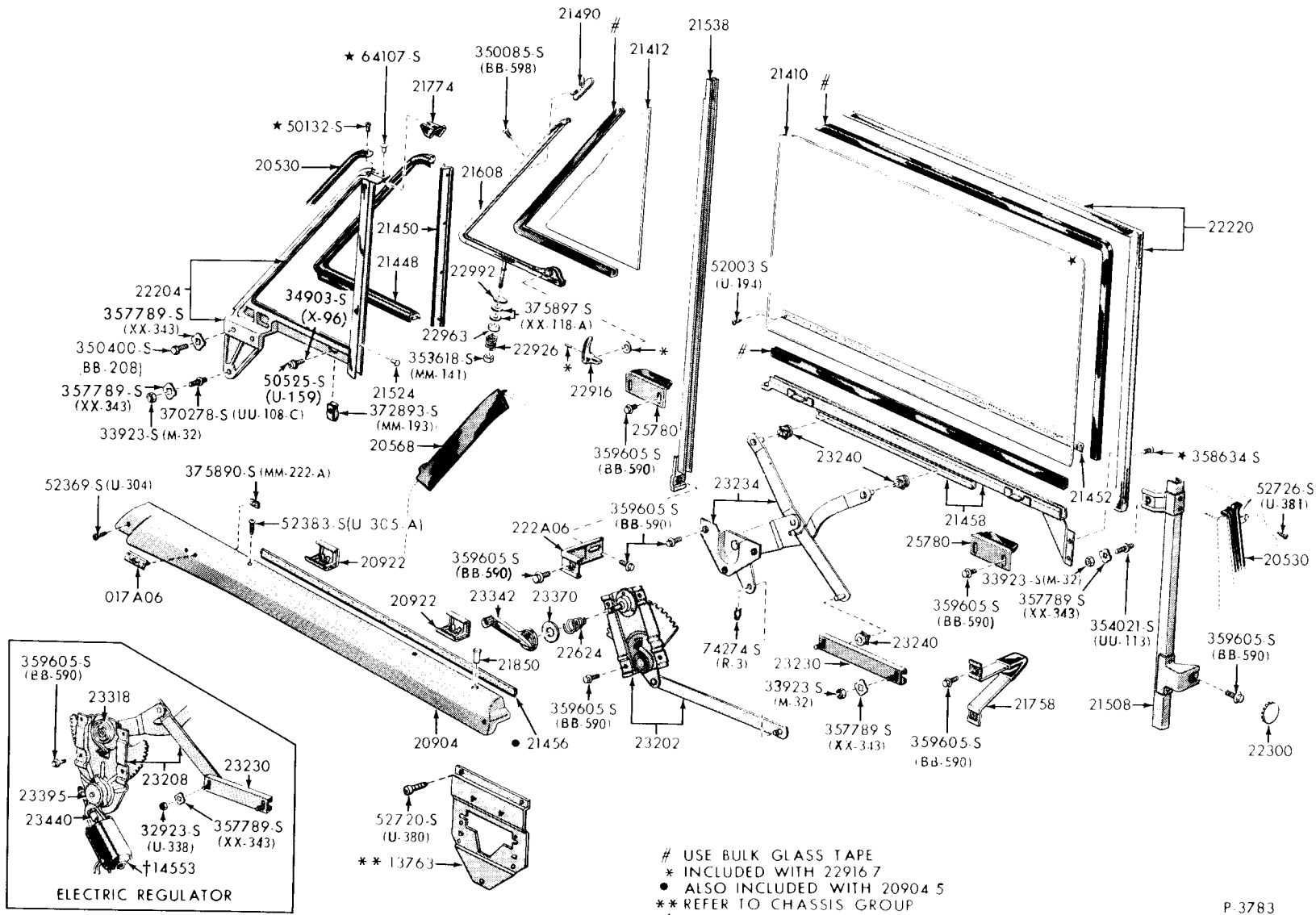

- # USE BULK GLASS TAPE
- * INCLUDED WITH 229167
- ALSO INCLUDED WITH 20904 5
- ** REFER TO CHASSIS GROUP
- † REFER TO GROUP IN CHASSIS SECTION

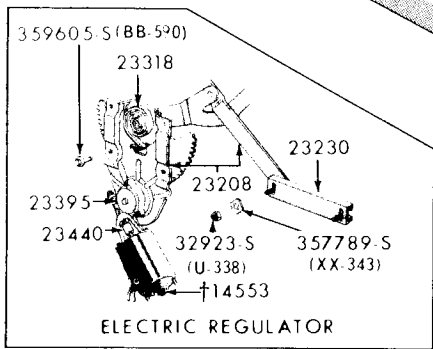
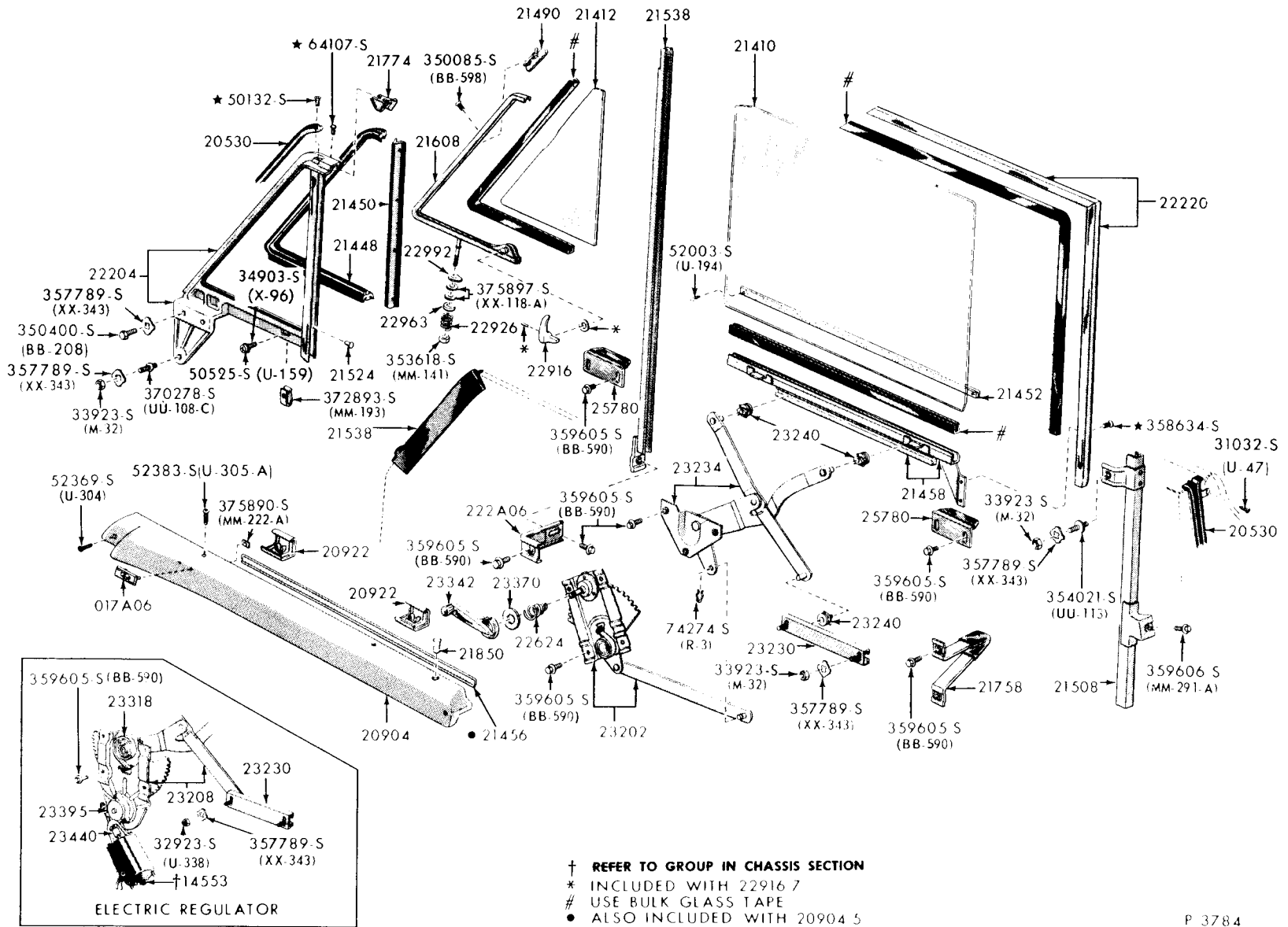

1962 DOOR WINDOW PARTS - BODY TYPE A (76)

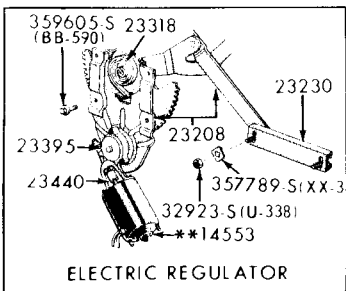
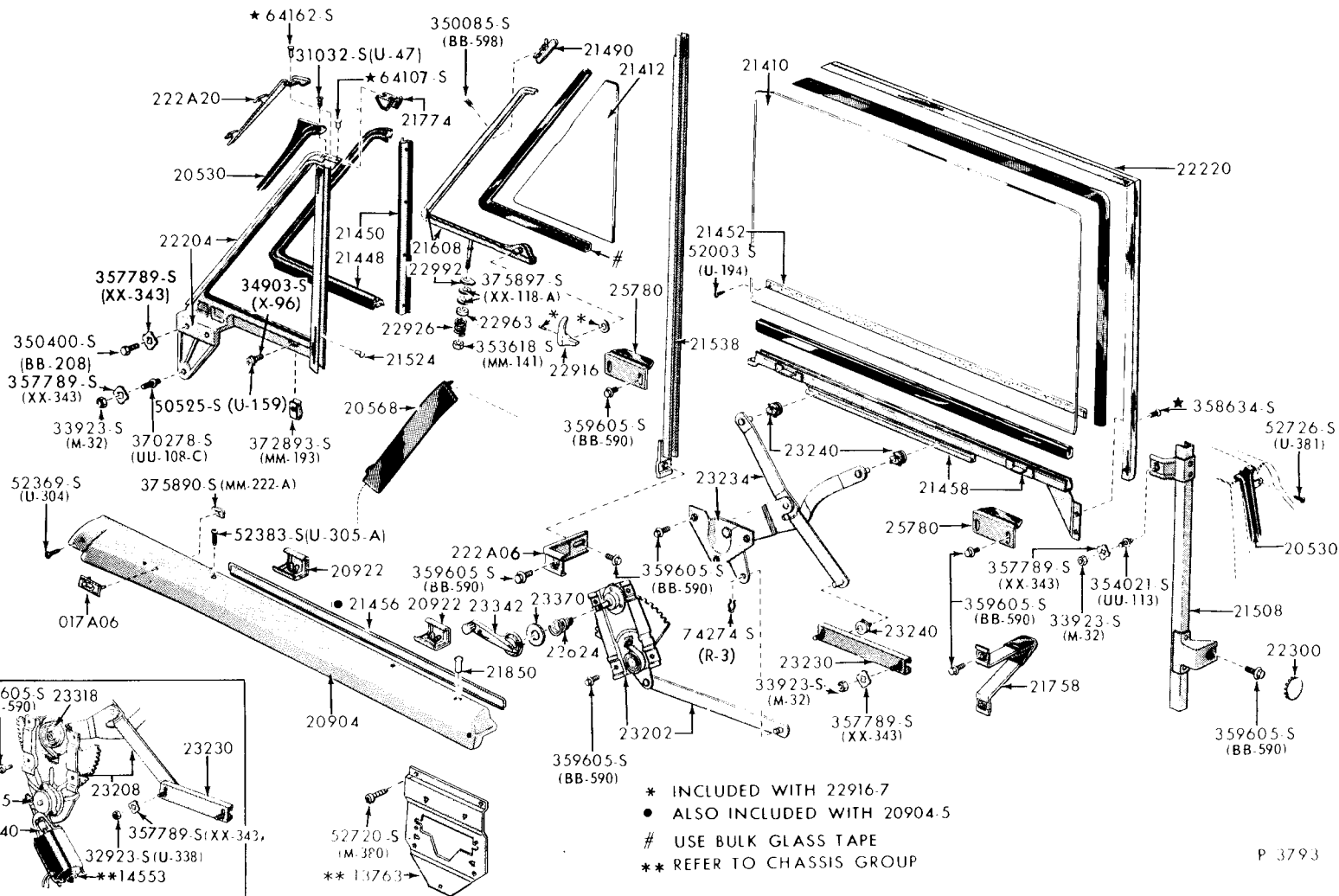

- * INCLUDED WITH 22916-7
- ALSO INCLUDED WITH 20904-5
- # USE BULK GLASS TAPE
- ** REFER TO CHASSIS GROUP

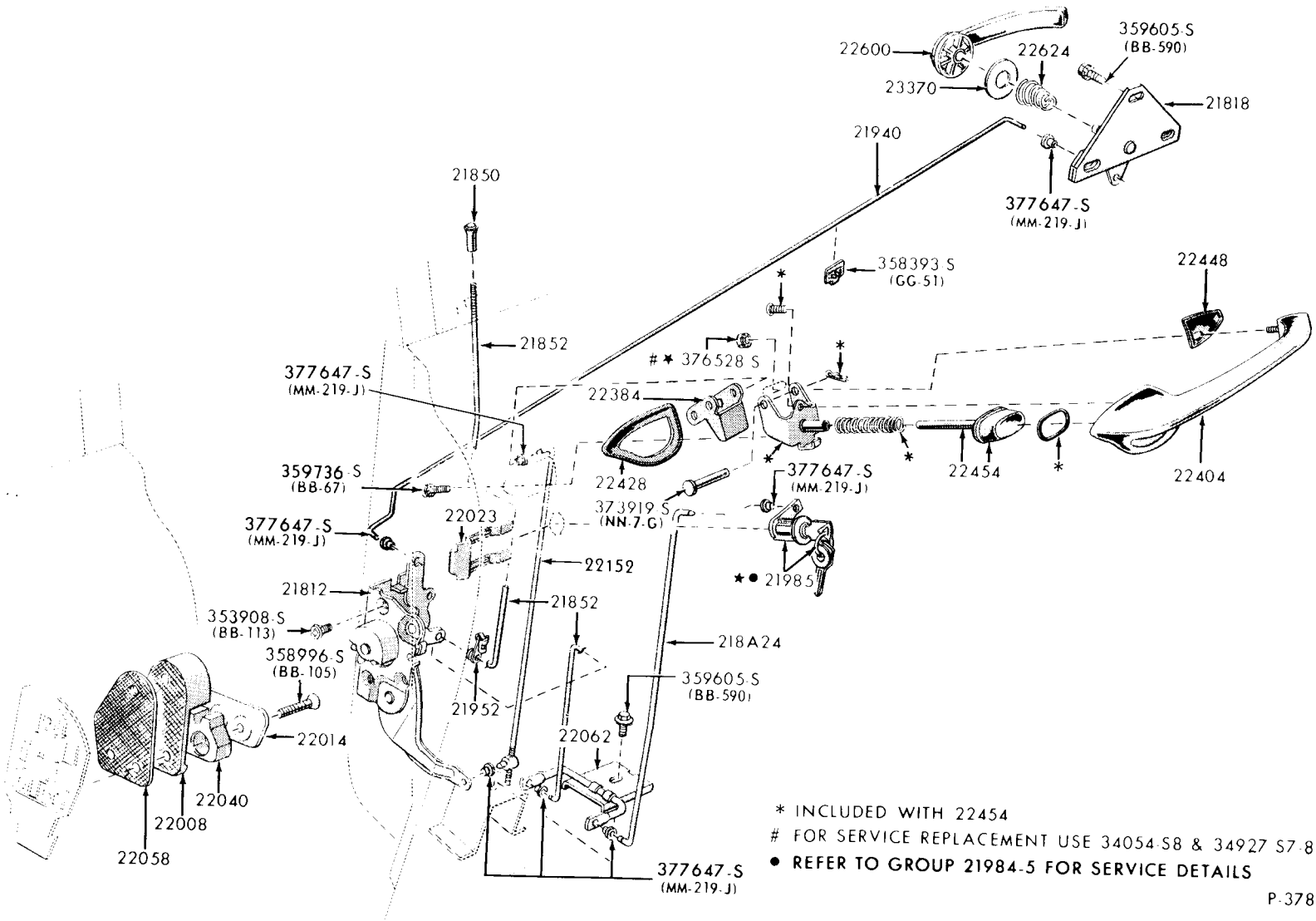

* INCLUDED WITH 22454

FOR SERVICE REPLACEMENT USE 34054 S8 & 34927 S7-8

● REFER TO GROUP 21984.5 FOR SERVICE DETAILS

P-3785

1962/64 FAIRLANE FRONT DOOR PARTS - BODY TYPES B(54,62,71) - TYPICAL - "Before 3/1/64"

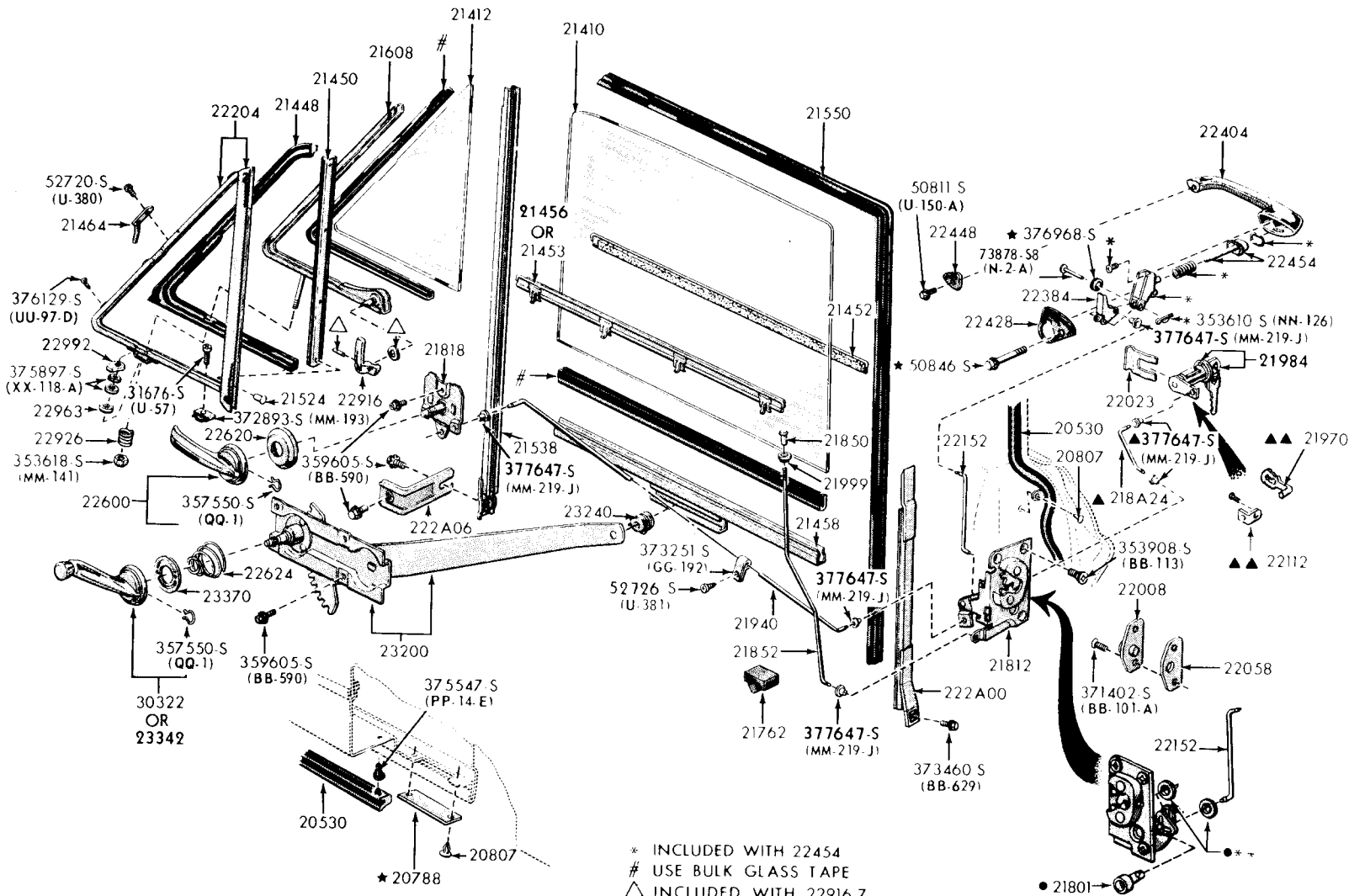

- * INCLUDED WITH 22454
- # USE BULK GLASS TAPE
- △ INCLUDED WITH 22916.7
- ALSO INCLUDED WITH 21812.3
- ** INCLUDED WITH 21801
- ▲ 1962 UNITS
- ▲▲ 1963/64 UNITS "BEFORE 3/1/64"

1963/64 FRONT DOOR WINDOW & RELATED PARTS-BODY TYPES A(67, 75)-TYPICAL.

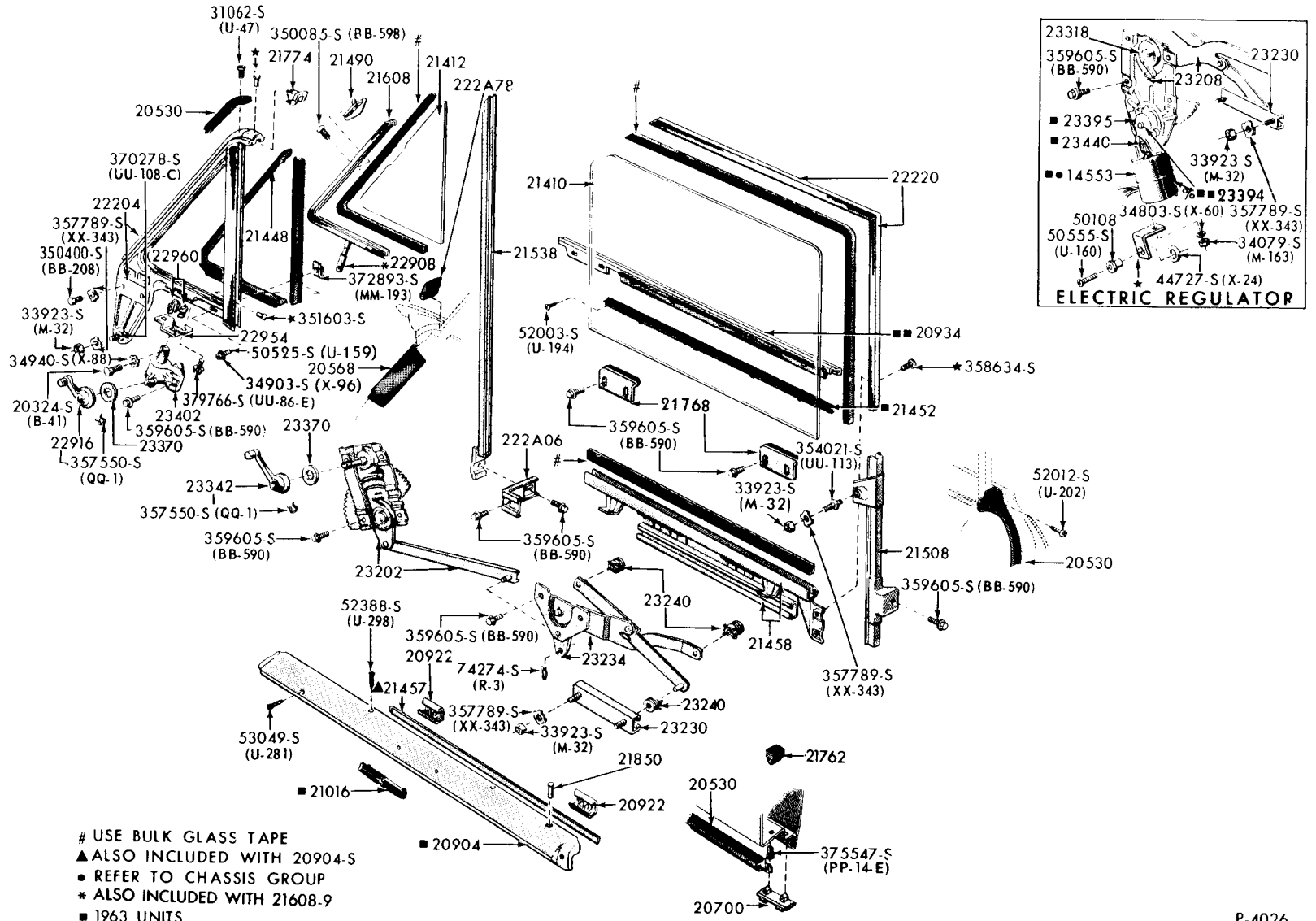

- # USE BULK GLASS TAPE
- ▲ ALSO INCLUDED WITH 20904-S
- REFER TO CHASSIS GROUP
- * ALSO INCLUDED WITH 21608-9
- 1963 UNITS
- 1964 UNITS
- % FOR GEAR REPLACEMENT KIT REFER TO GROUP 234A24

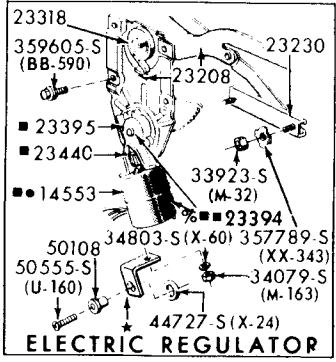

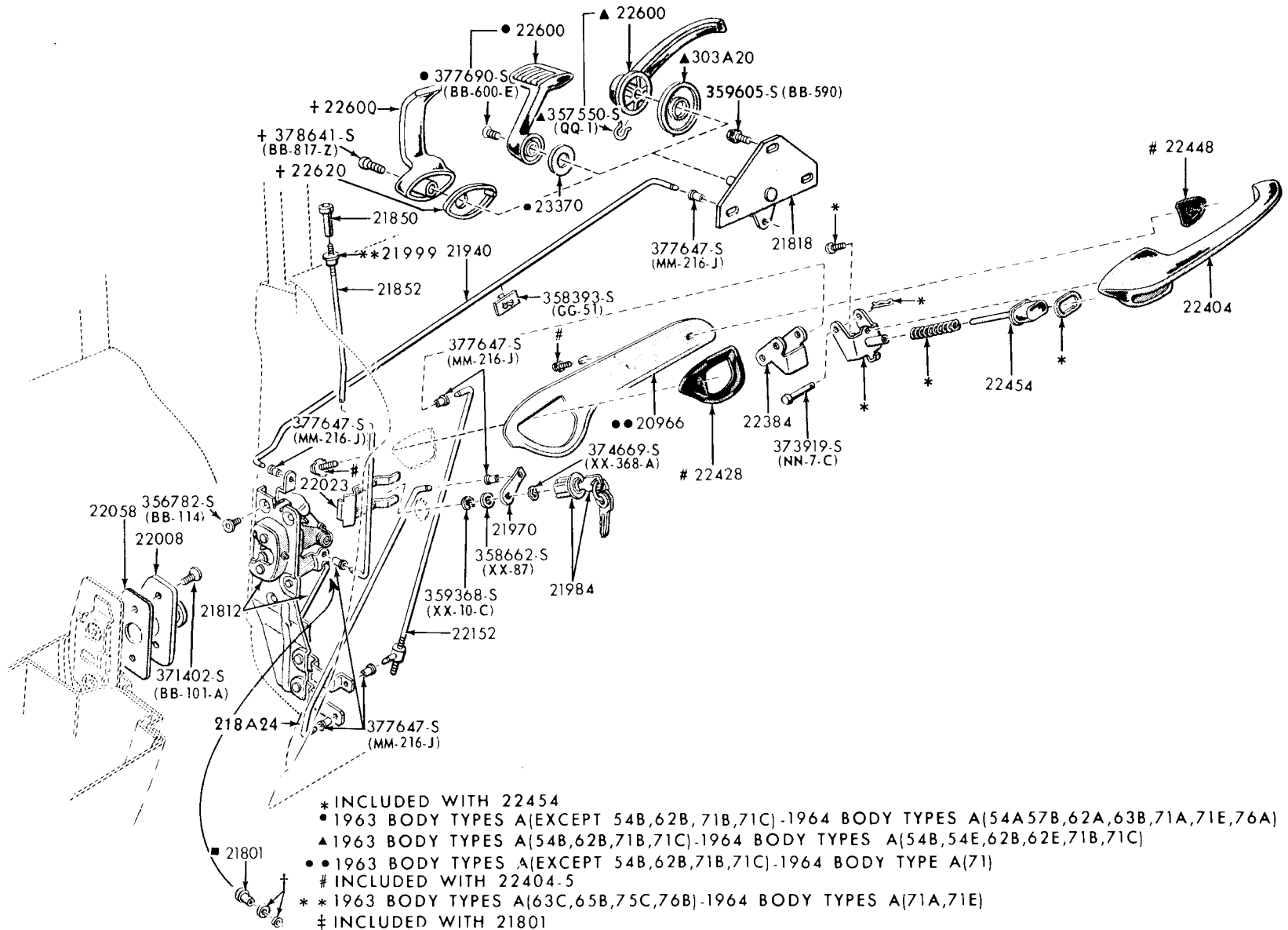

- * INCLUDED WITH 22454
- 1963 BODY TYPES A (EXCEPT 54B, 62B, 71B, 71C) - 1964 BODY TYPES A (54A, 57B, 62A, 63B, 71A, 71E, 76A)
- ▲ 1963 BODY TYPES A (54B, 62B, 71B, 71C) - 1964 BODY TYPES A (54B, 54E, 62B, 62E, 71B, 71C)
- 1963 BODY TYPES A (EXCEPT 54B, 62B, 71B, 71C) - 1964 BODY TYPE A (71)
- # INCLUDED WITH 22404-5
- * 1963 BODY TYPES A (63C, 65B, 75C, 76B) - 1964 BODY TYPES A (71A, 71E)
- ‡ INCLUDED WITH 21801
- ALSO INCLUDED WITH 21812-3
- † 1964 BODY TYPES A (57C, 63C, 76B)

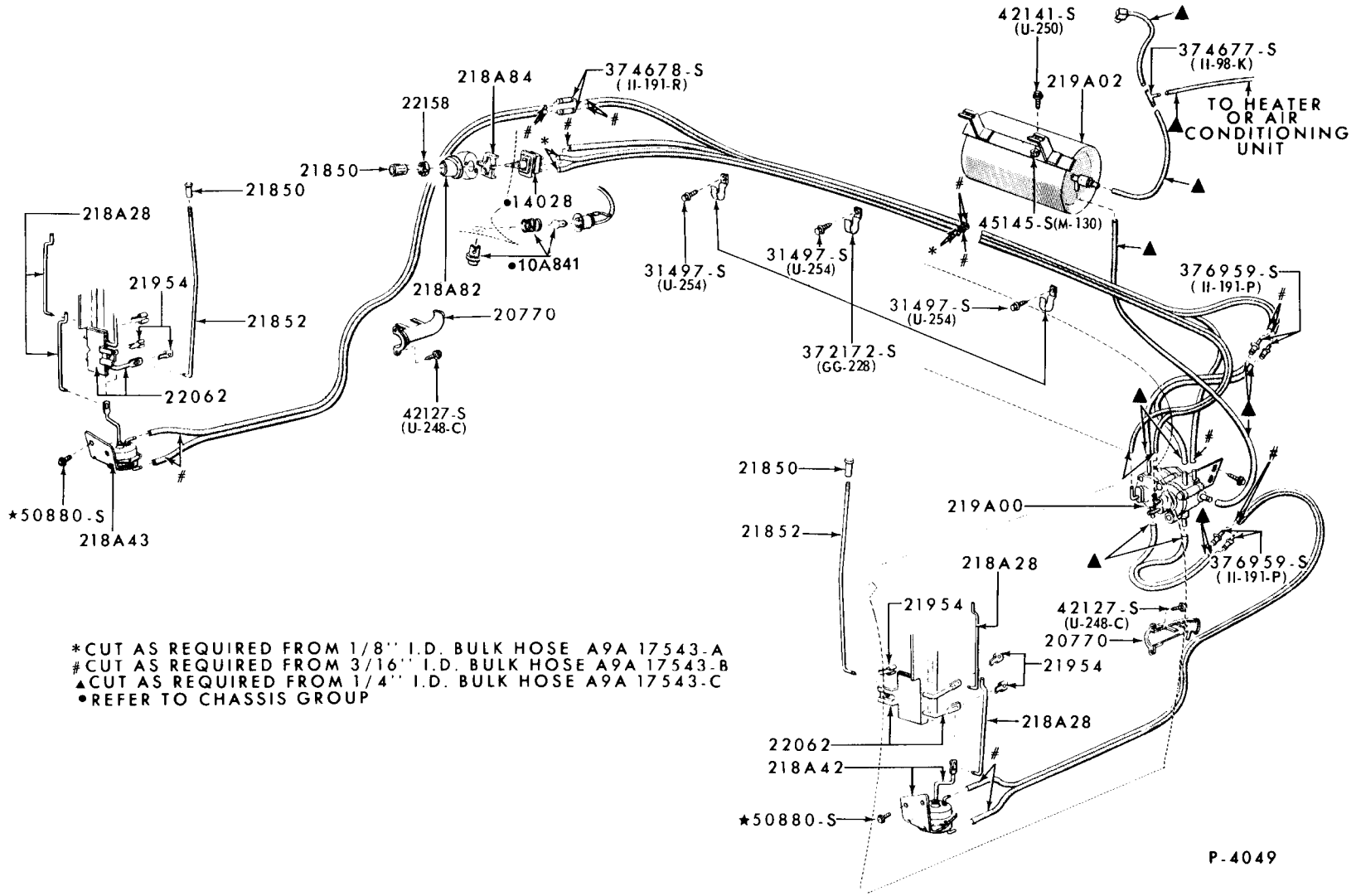

P-4049

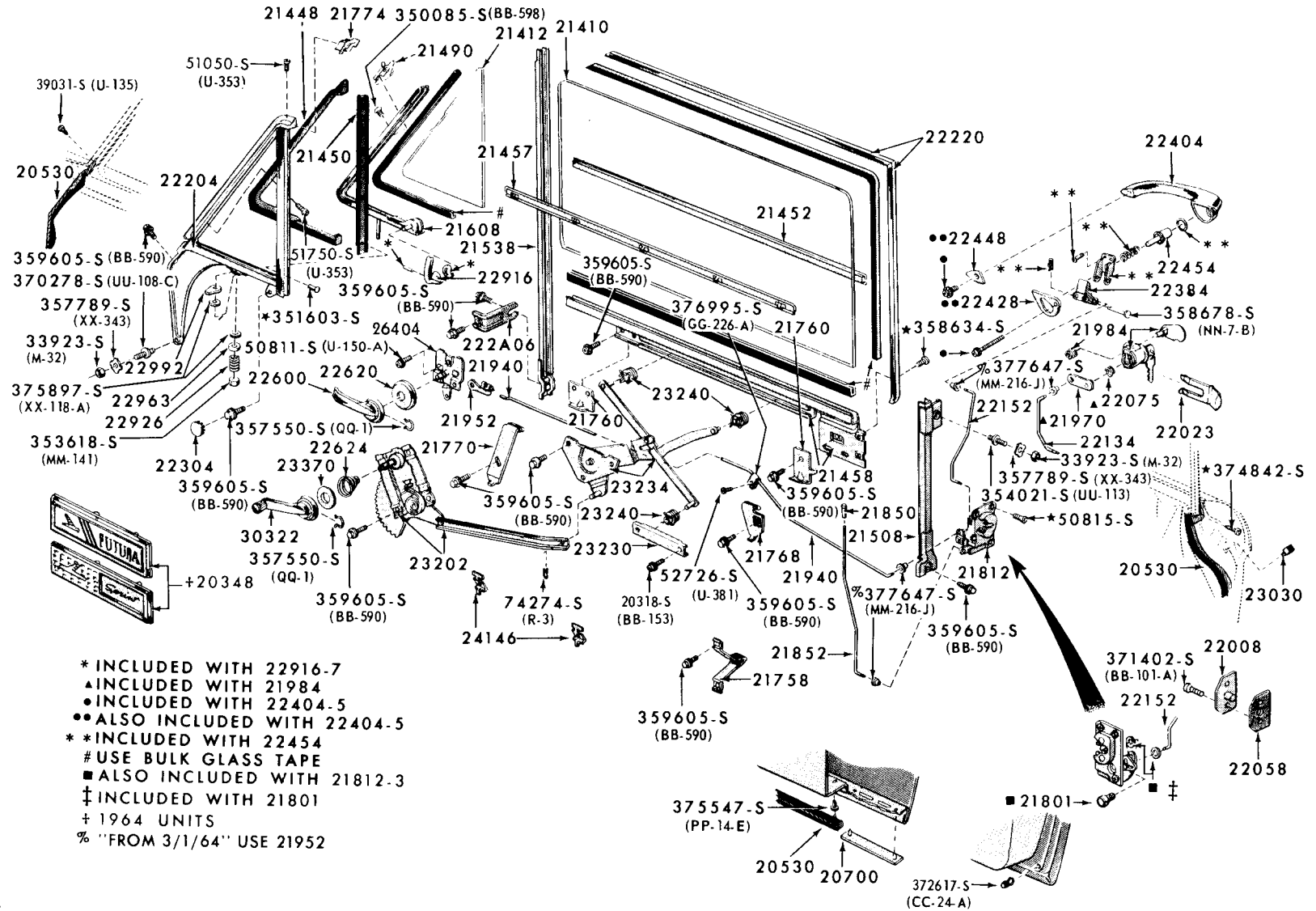

1964/
FRONT DOOR WINDOW and RELATED PARTS
FAIRLANE - BODY TYPES 54, 62, 71 - "FROM 3/1/64"

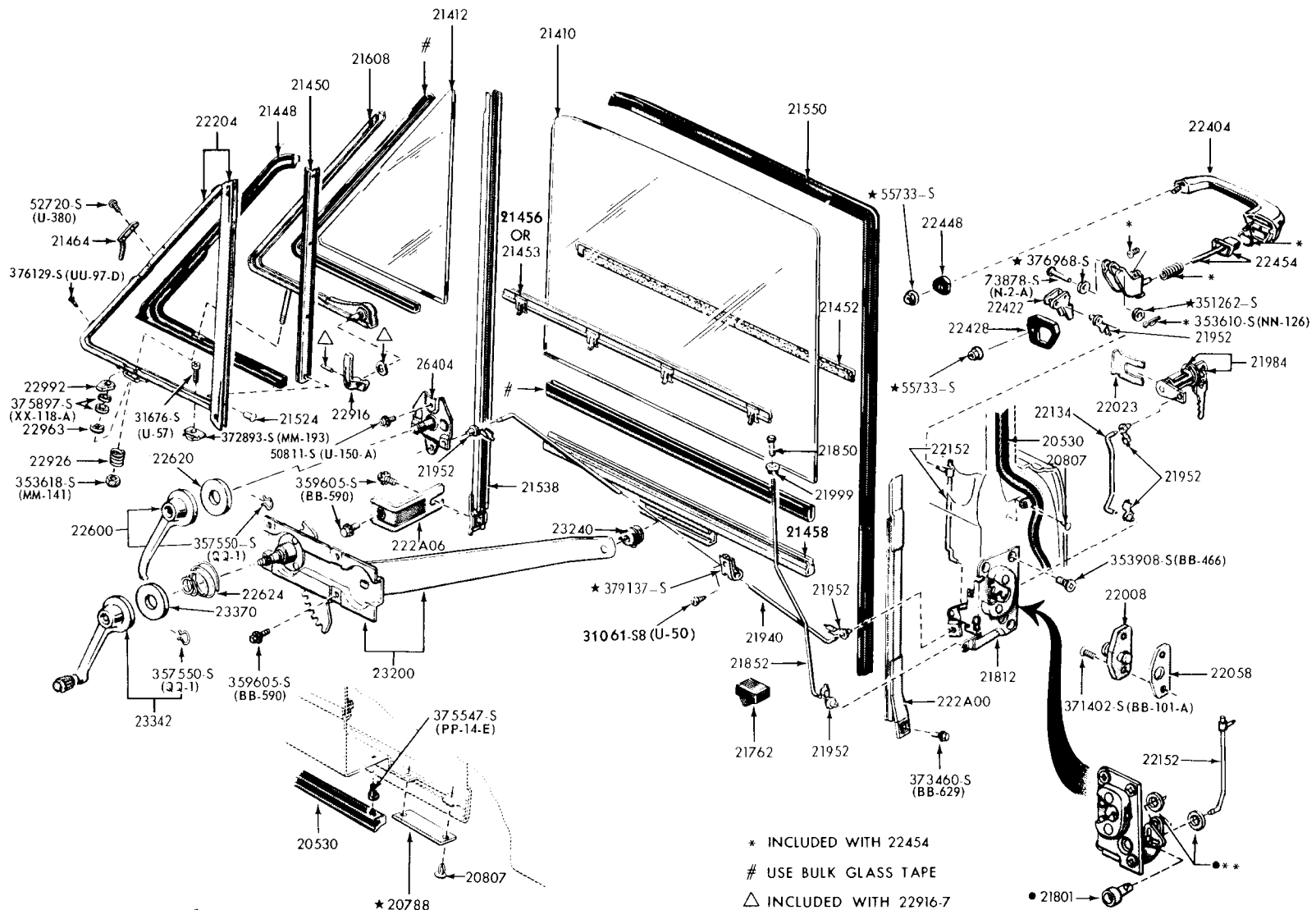

- * INCLUDED WITH 22454
- # USE BULK GLASS TAPE
- △ INCLUDED WITH 22916-7
- ALSO INCLUDED WITH 21812-3
- ** INCLUDED WITH 21801

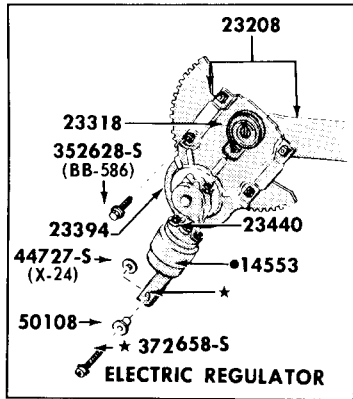
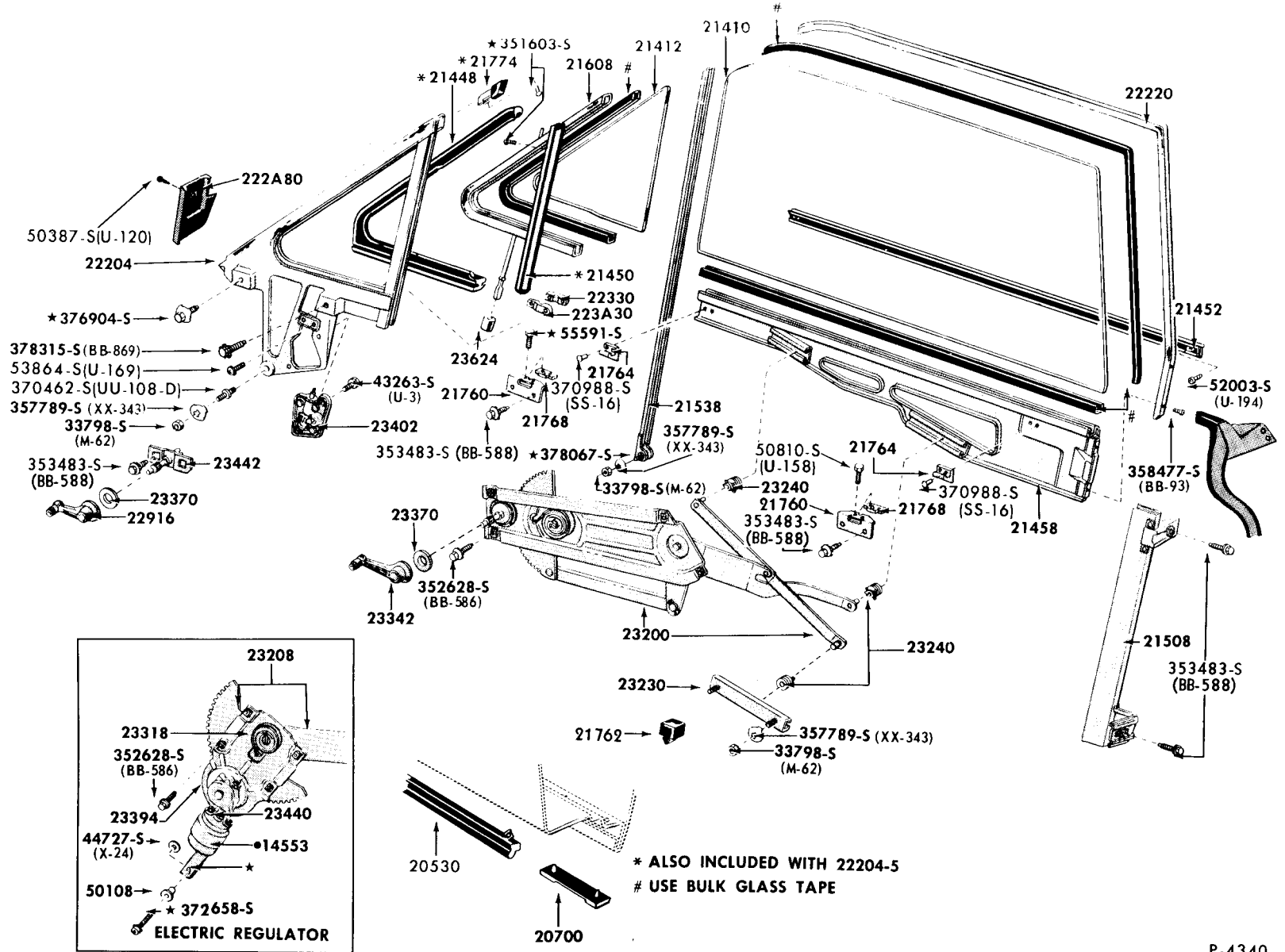

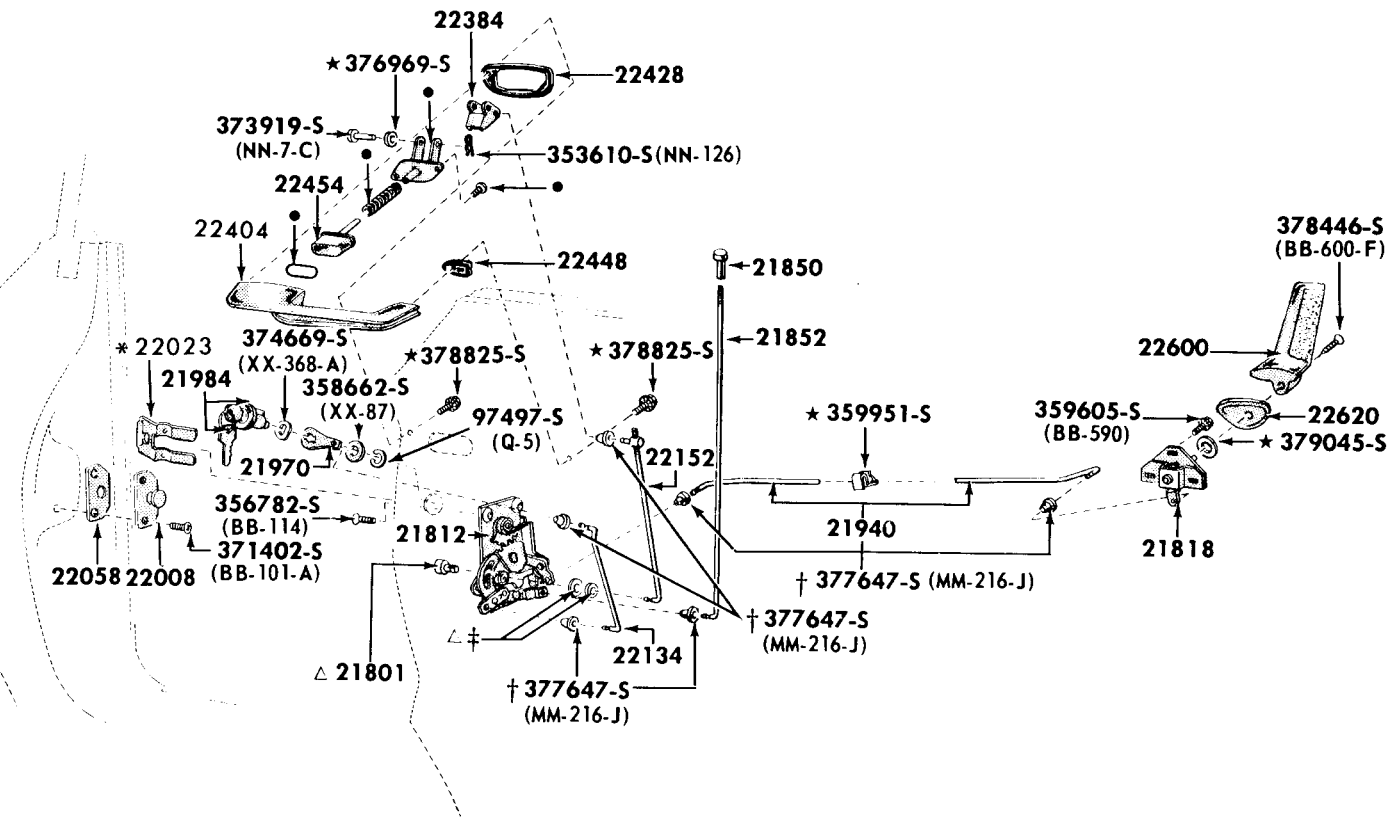

- * ALSO INCLUDED WITH 21984
- INCLUDED WITH 22454
- △ ALSO INCLUDED WITH 21812
- ‡ INCLUDED WITH 21801
- † "FROM 3/1/64" USE 21952

P-4341

VACUUM DOOR LATCH and RELATED PARTS
1964/ THUNDERBIRD

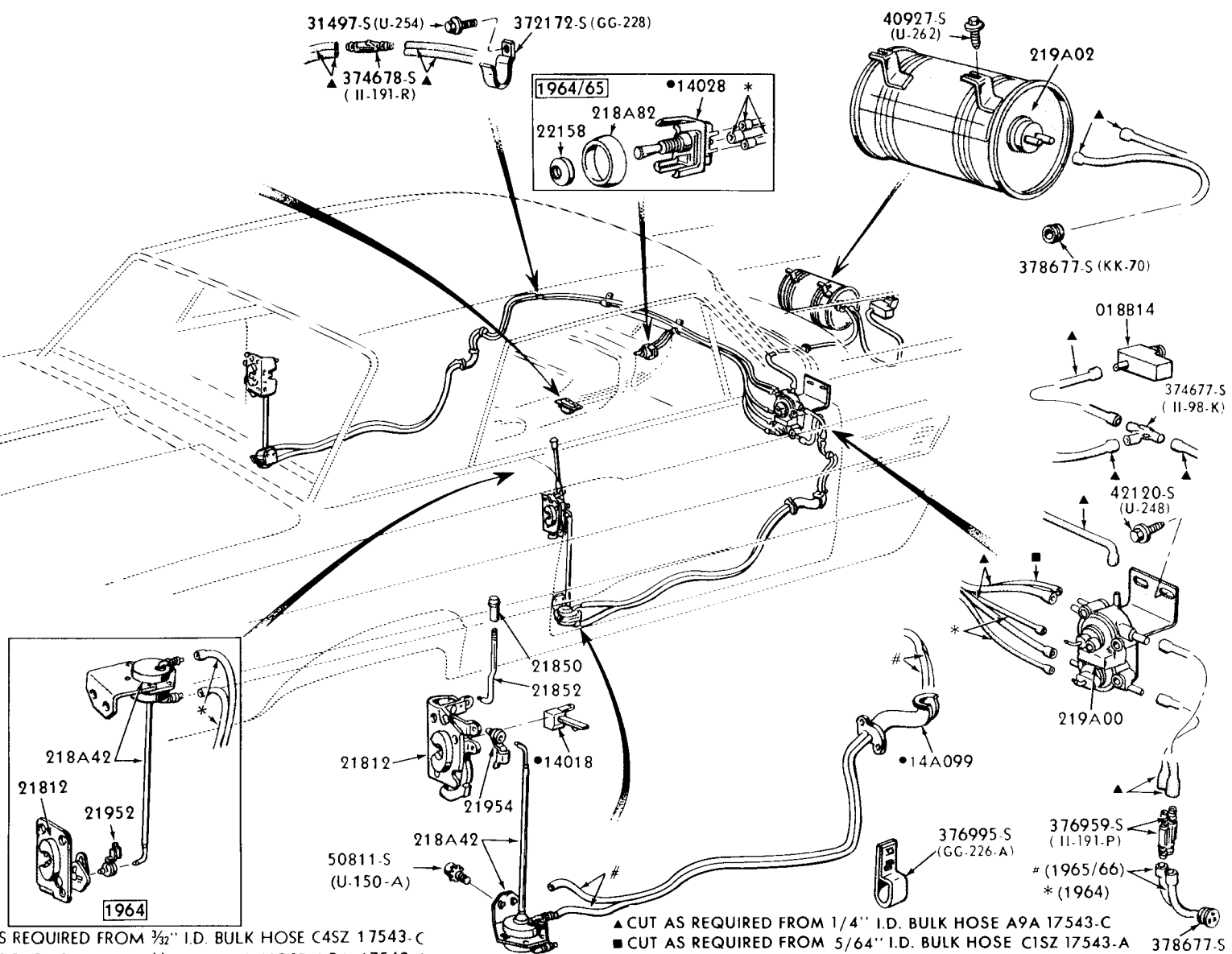

O CUT AS REQUIRED FROM 3/32" I.D. BULK HOSE C4SZ 17543-C
 * CUT AS REQUIRED FROM 1/8" I.D. BULK HOSE A9A 17543-A
 # CUT AS REQUIRED FROM 3/16" I.D. BULK HOSE A9A 17543-B

▲ CUT AS REQUIRED FROM 1/4" I.D. BULK HOSE A9A 17543-C
 ■ CUT AS REQUIRED FROM 5/64" I.D. BULK HOSE C1SZ 17543-A
 ◆ CUT AS REQUIRED FROM 5/32" I.D. BULK HOSE C4SZ 17543-A
 • REFER TO CHASSIS SECTION GROUP

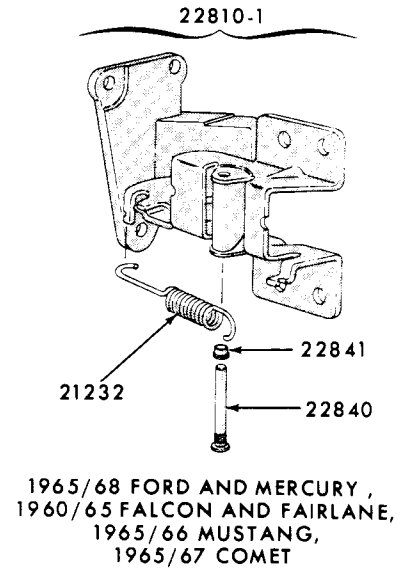
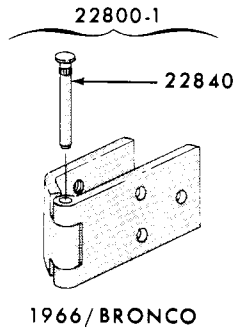
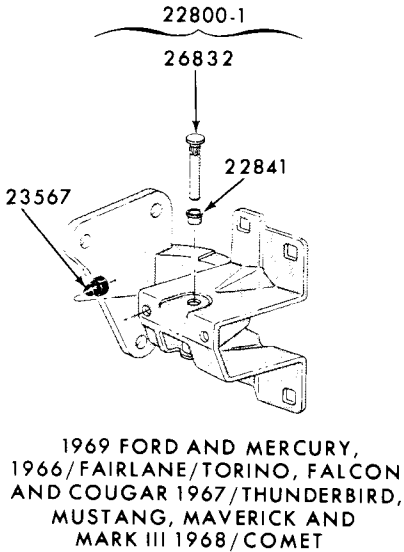
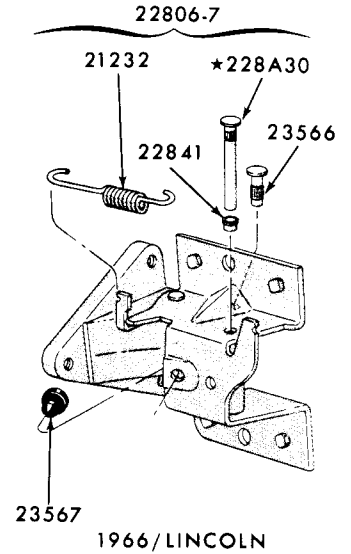
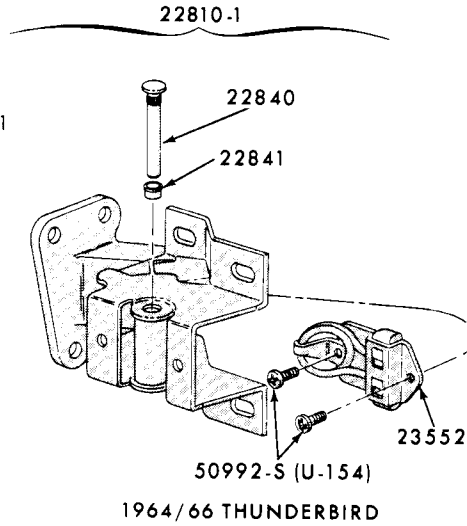
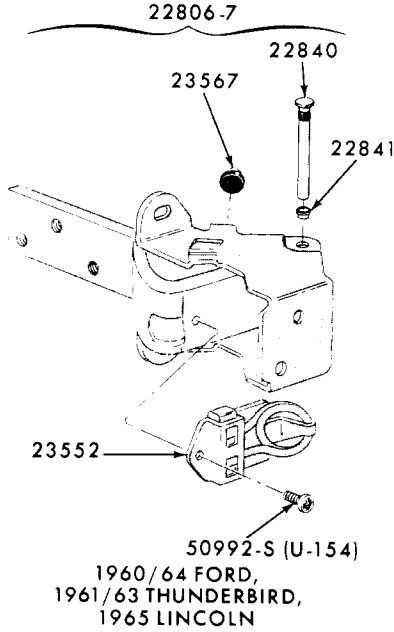

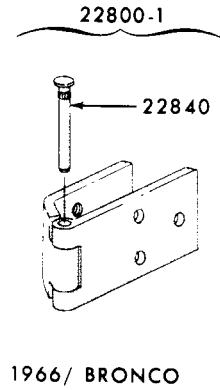
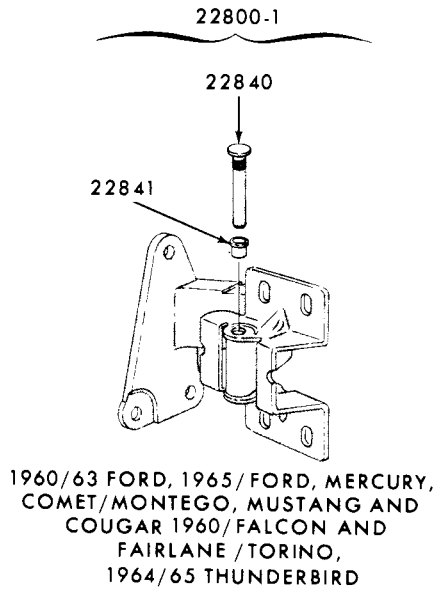
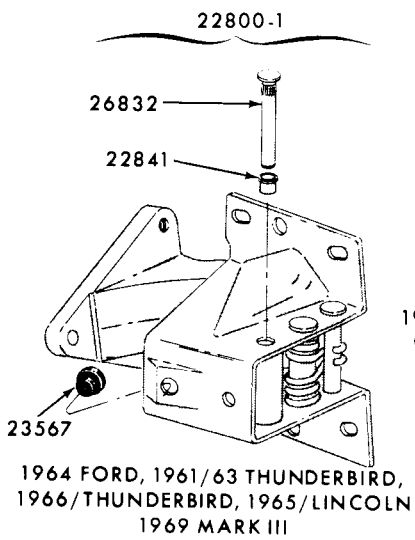

P-6980

FRONT DOOR HINGE - UPPER
1960/ FAIRLANE, FALCON, FORD and THUNDERBIRD - TYPICAL

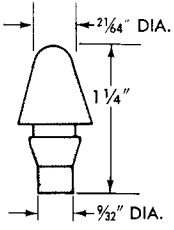

★352848-S

REPLACED BY 372486-S

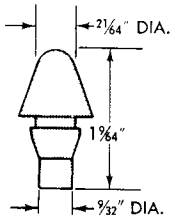

358712-S
(CC-13)

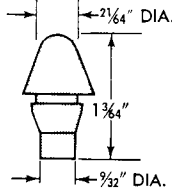

358713-S
(CC-13)

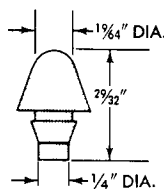

354434-S
(CC-4)

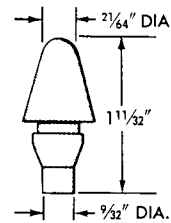

359933-S
(CC-33)

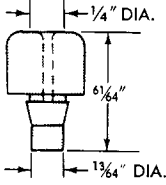

371496-S
(CC-2)

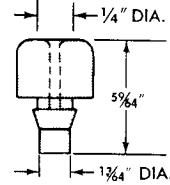

354860-S
(CC-6)

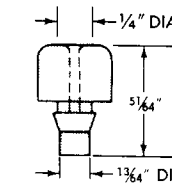

377781-S
(CC-34)

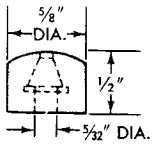

358953-S
(CC-18)

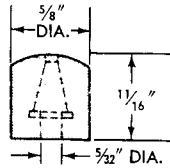

358939-S
(CC-17)

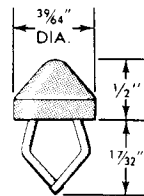

372617-S
(CC-24-A)

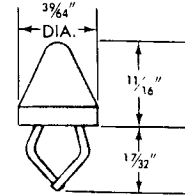

372486-S
(CC-24)

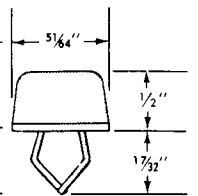

C20Z-6223030-A

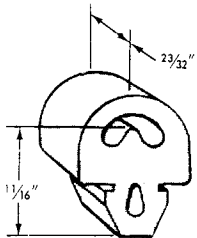

C7AZ-54265A28-A

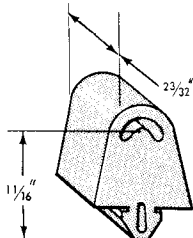

C80Z-54265A28-A

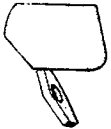

C20Z-5427224-A

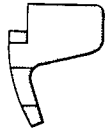

C20Z-5423036-A

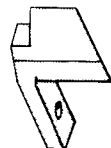

C20Z-6223036-A

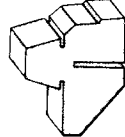

C2AZ-6223030-A

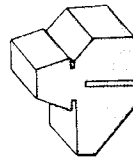

C3DZ7623030-A



C3AZ6223036.A

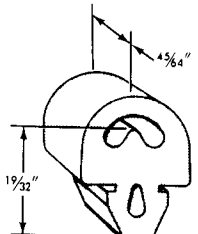

C7SZ6523030-A

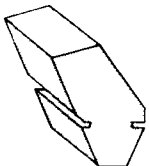

C3AZ-5423030-A

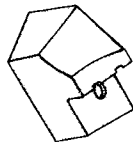

C30Z-6523036-A

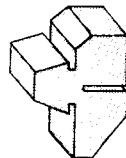

C4SZ-6323030-A

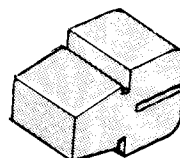

C5AZ-57265A28-A

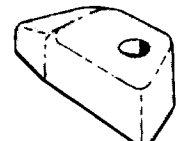

C7SZ5723036-A

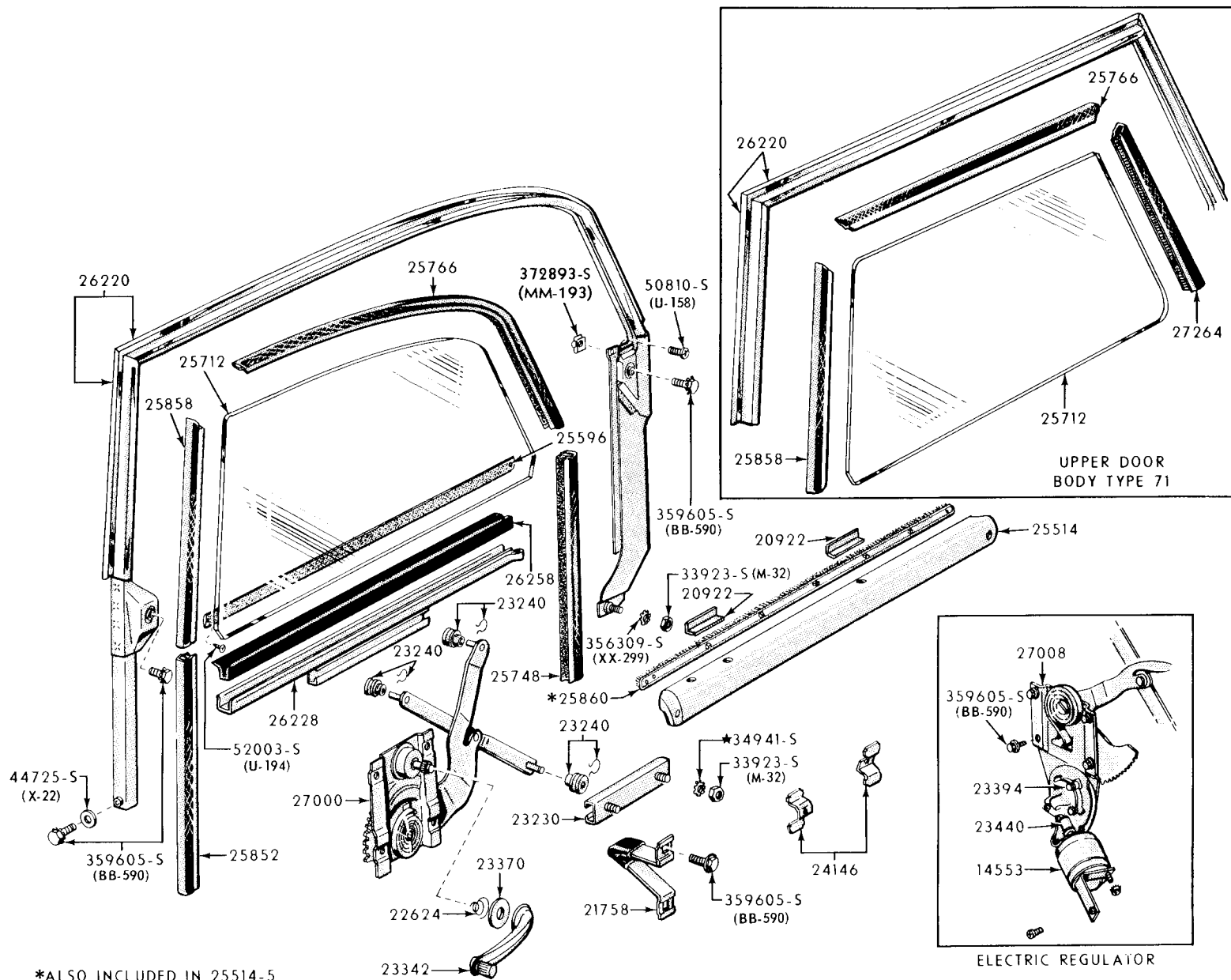

ELECTRIC REGULATOR

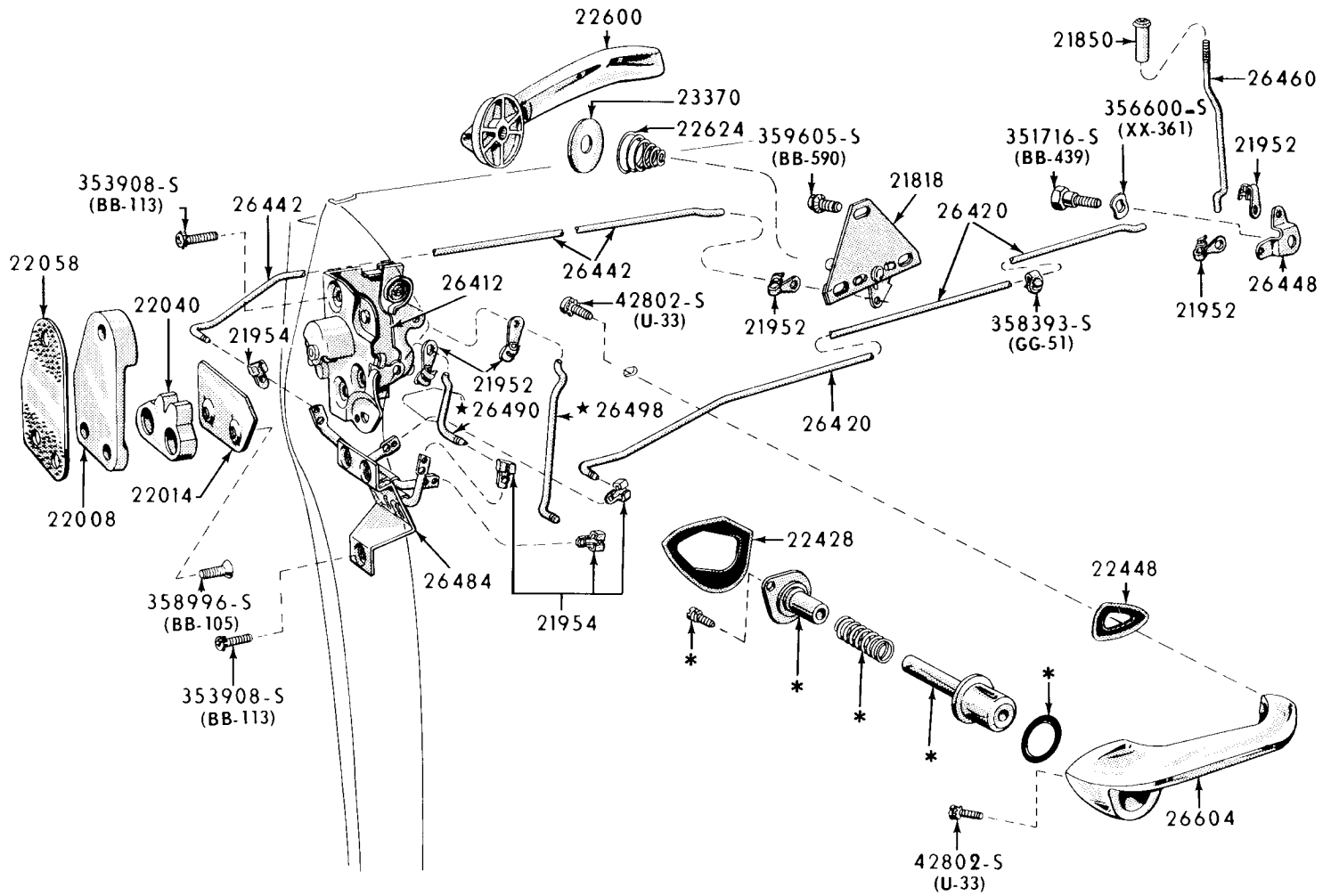

* SERVICED IN KIT 26410

P-3029

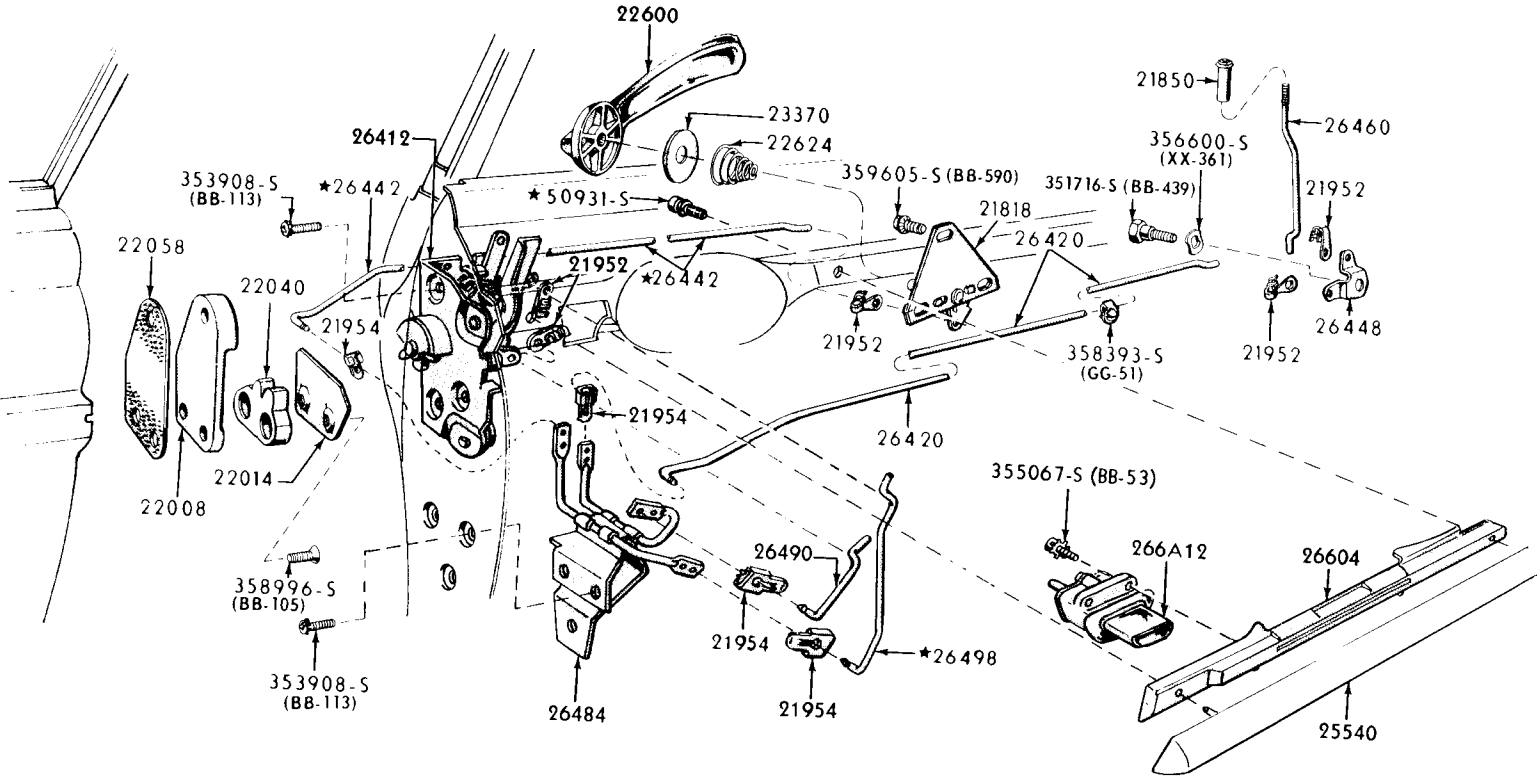

1961 REAR DOOR OUTSIDE HANDLE, LOCK & RELATED PARTS - BODY TYPES A(64, 58, 71)

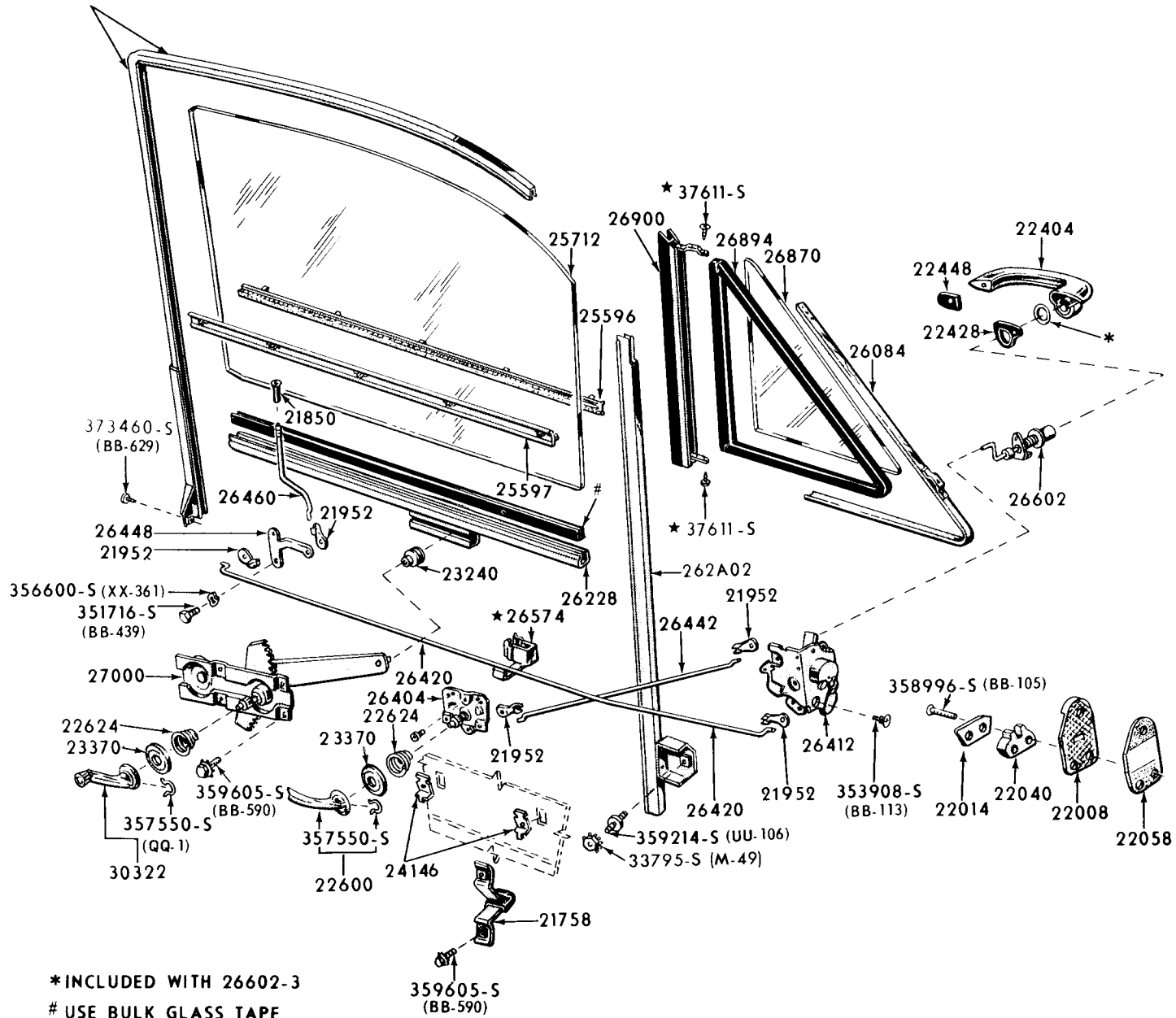

* INCLUDED WITH 26602-3

USE BULK GLASS TAPE



1962 REAR DOOR WINDOW PARTS - BODY TYPES A(54,71)

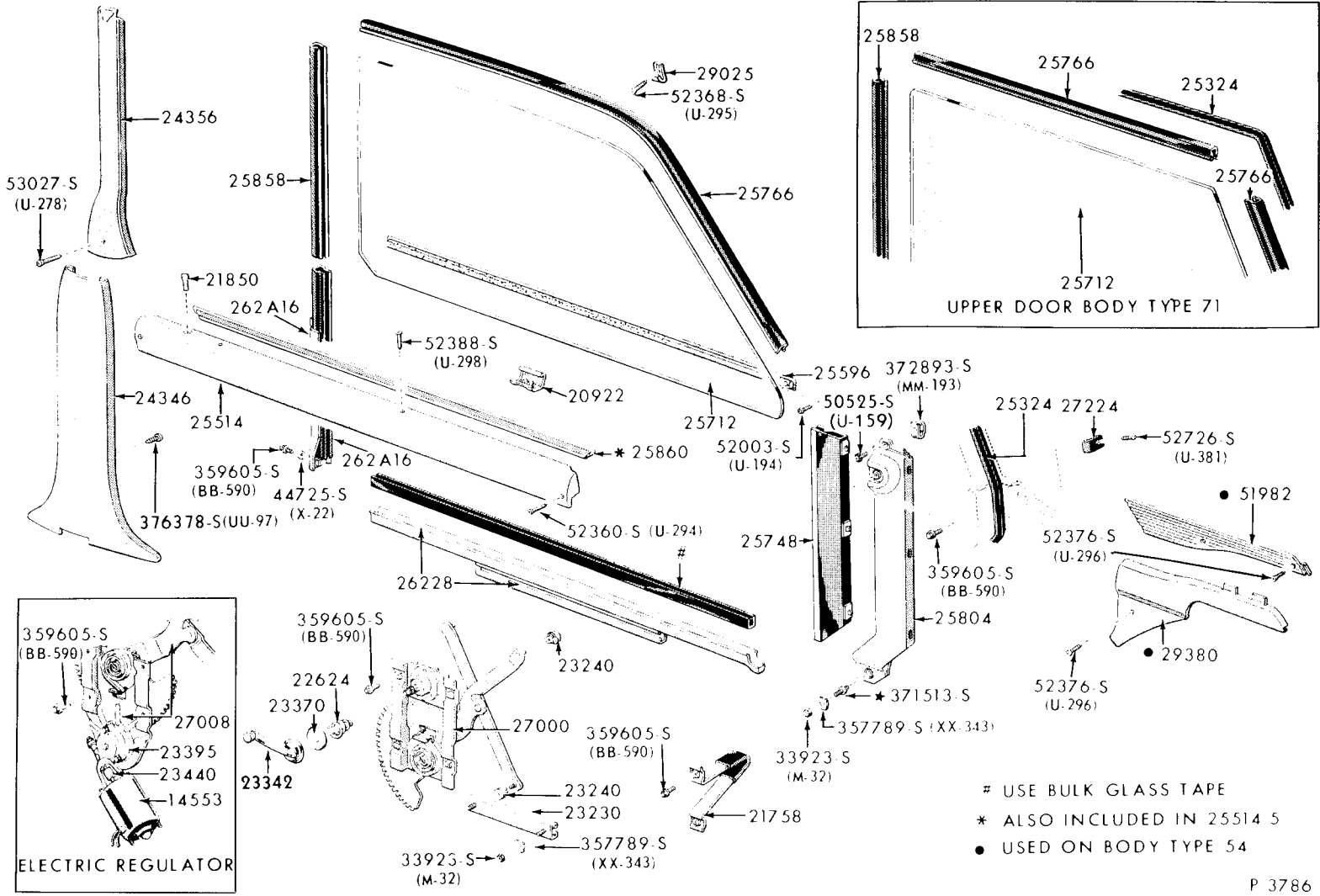

- # USE BULK GLASS TAPE
- * ALSO INCLUDED IN 25514 S
- USED ON BODY TYPE 54

P 3786

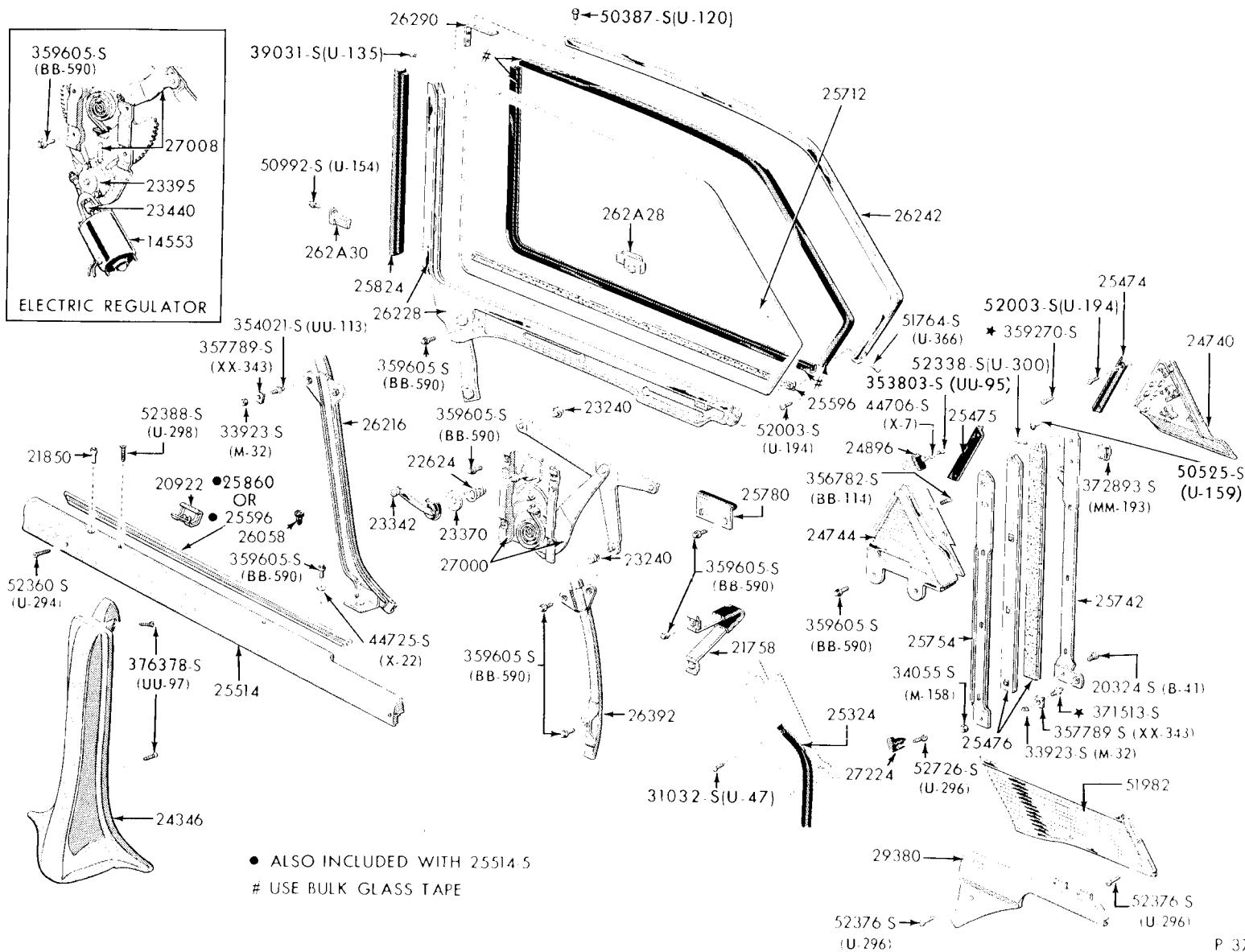

1962 REAR DOOR WINDOW PARTS-BODY TYPE A(75)

● ALSO INCLUDED WITH 25514.5
USE BULK GLASS TAPE

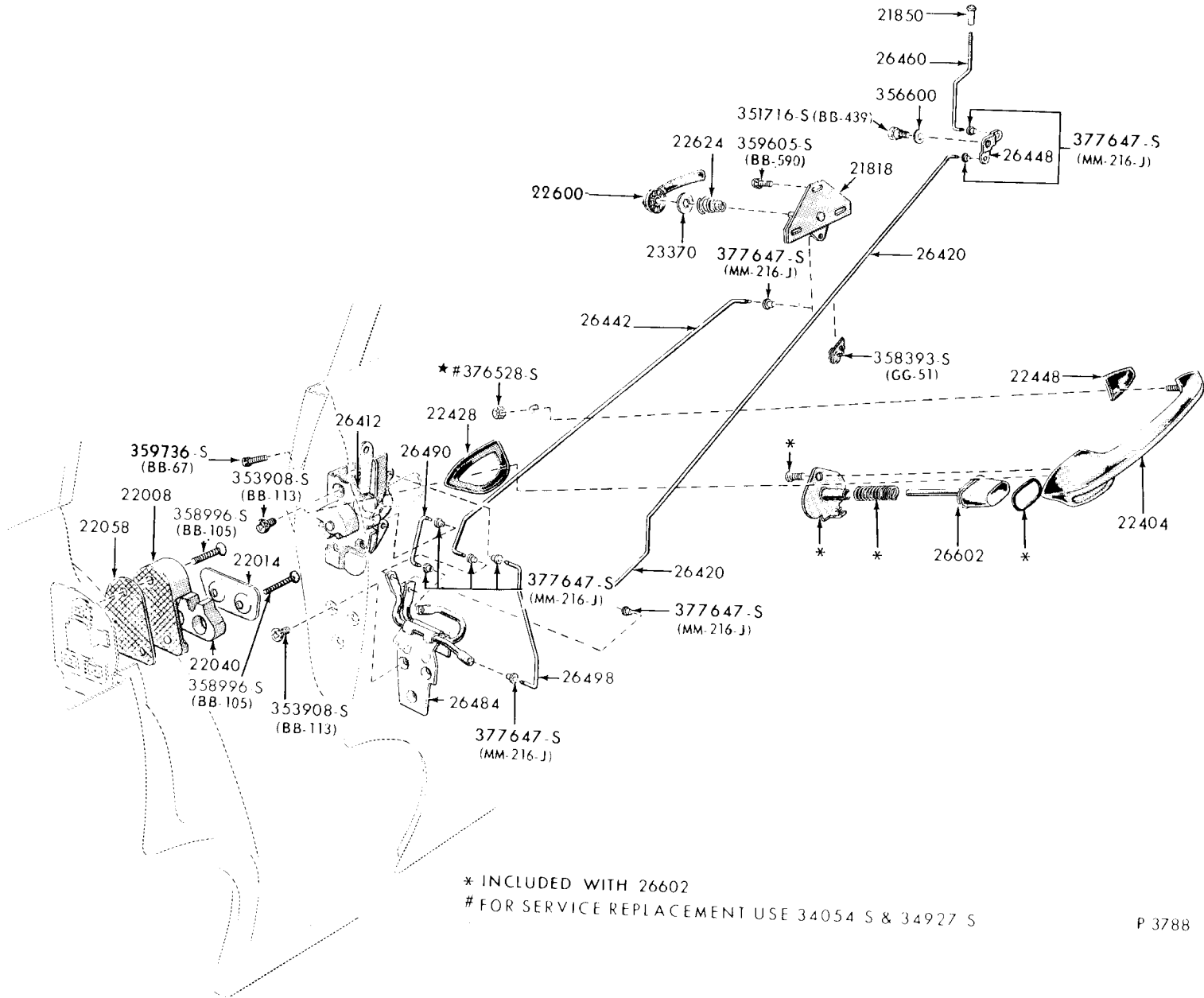

* INCLUDED WITH 26602
FOR SERVICE REPLACEMENT USE 34054 S & 34927 S

P 3788

1962 / FAIRLANE REAR DOOR PARTS - BODY TYPES B(54, 71)-TYPICAL

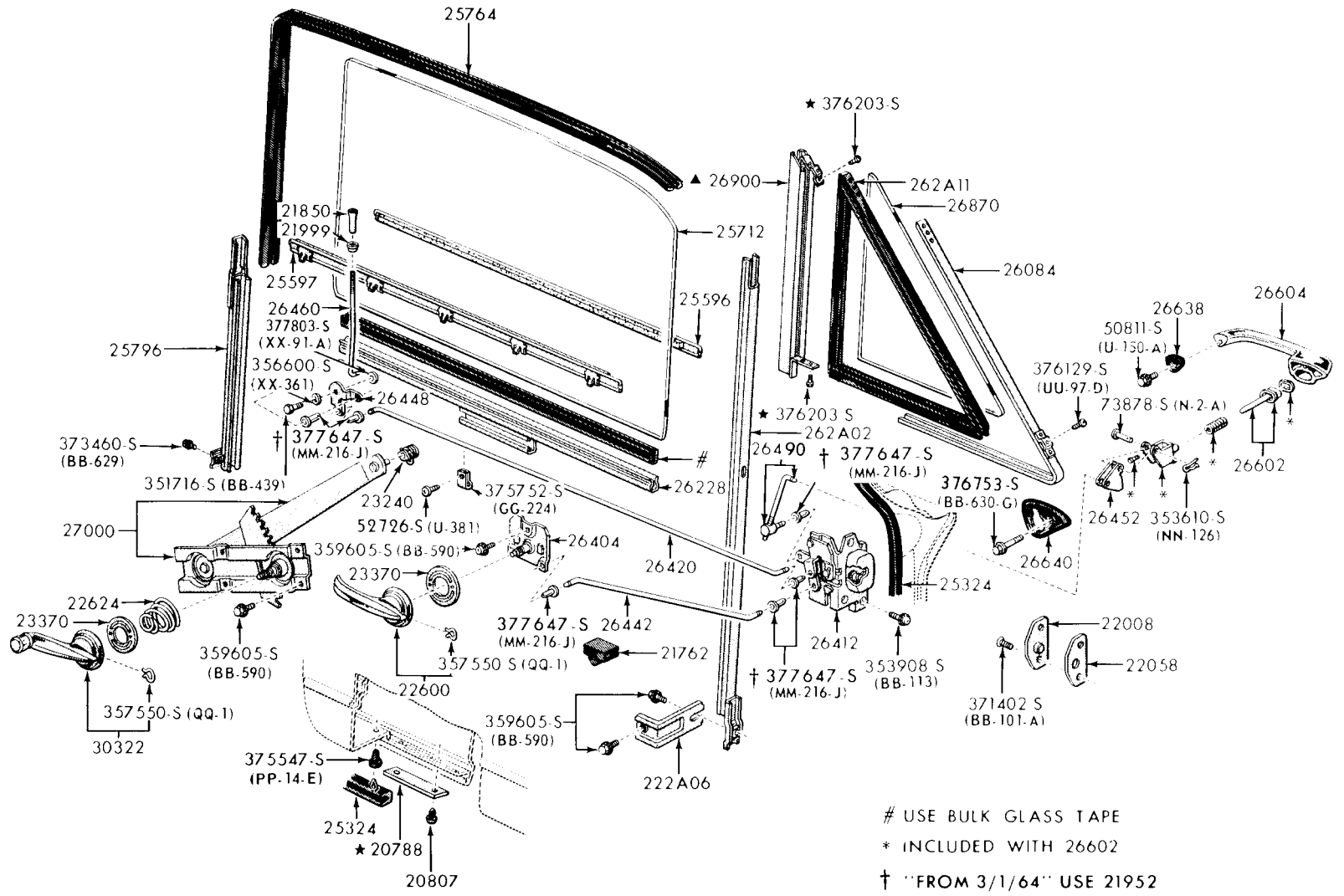

USE BULK GLASS TAPE
 * INCLUDED WITH 26602
 † "FROM 3/1/64" USE 21952
 ▲ 1962/64 ONLY

1963 REAR DOOR WINDOW & RELATED PARTS - BODY TYPE A(75)-TYPICAL

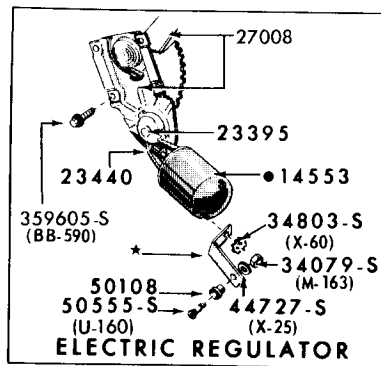
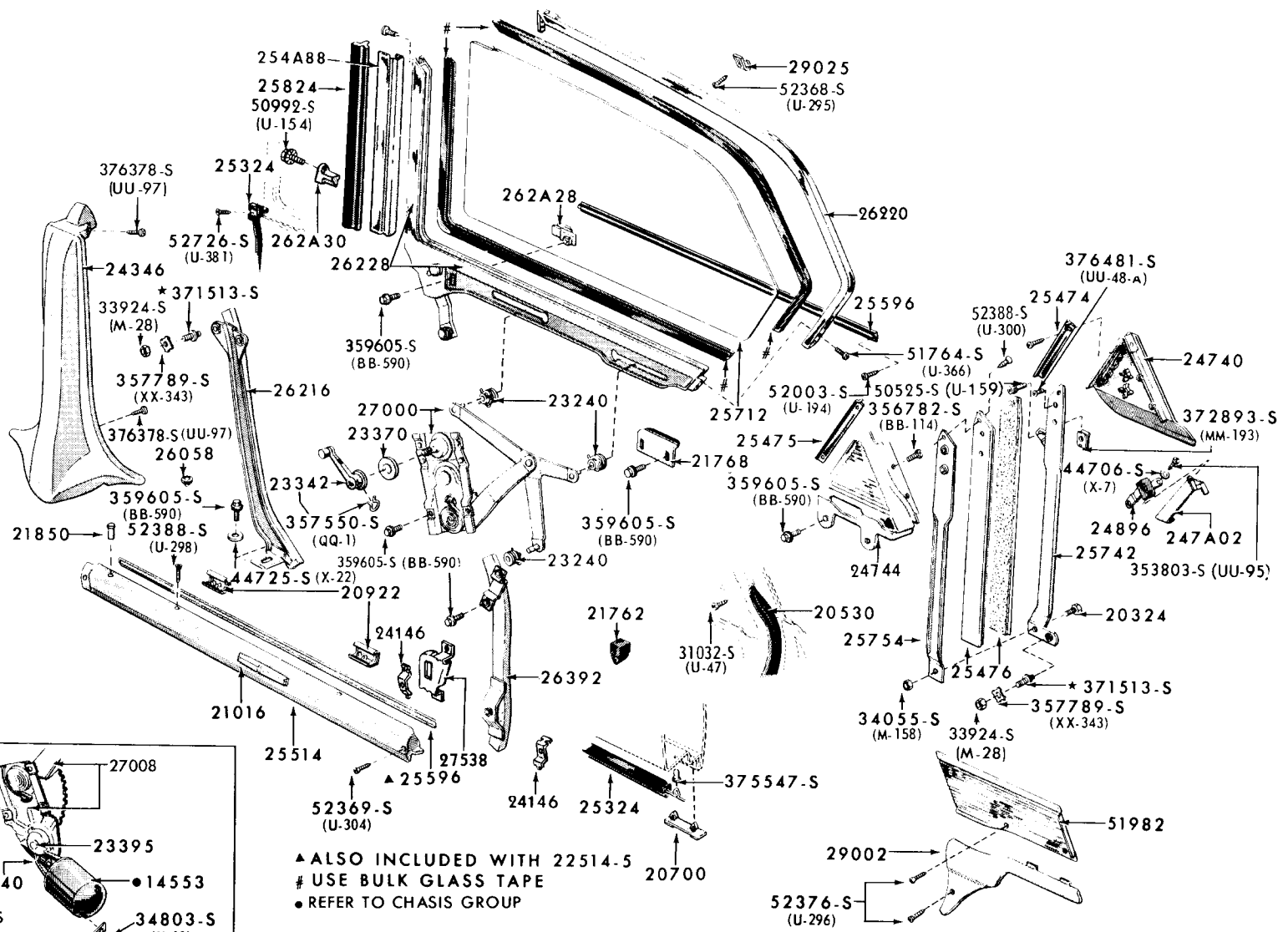

- ▲ ALSO INCLUDED WITH 22514.5
- # USE BULK GLASS TAPE
- REFER TO CHASIS GROUP

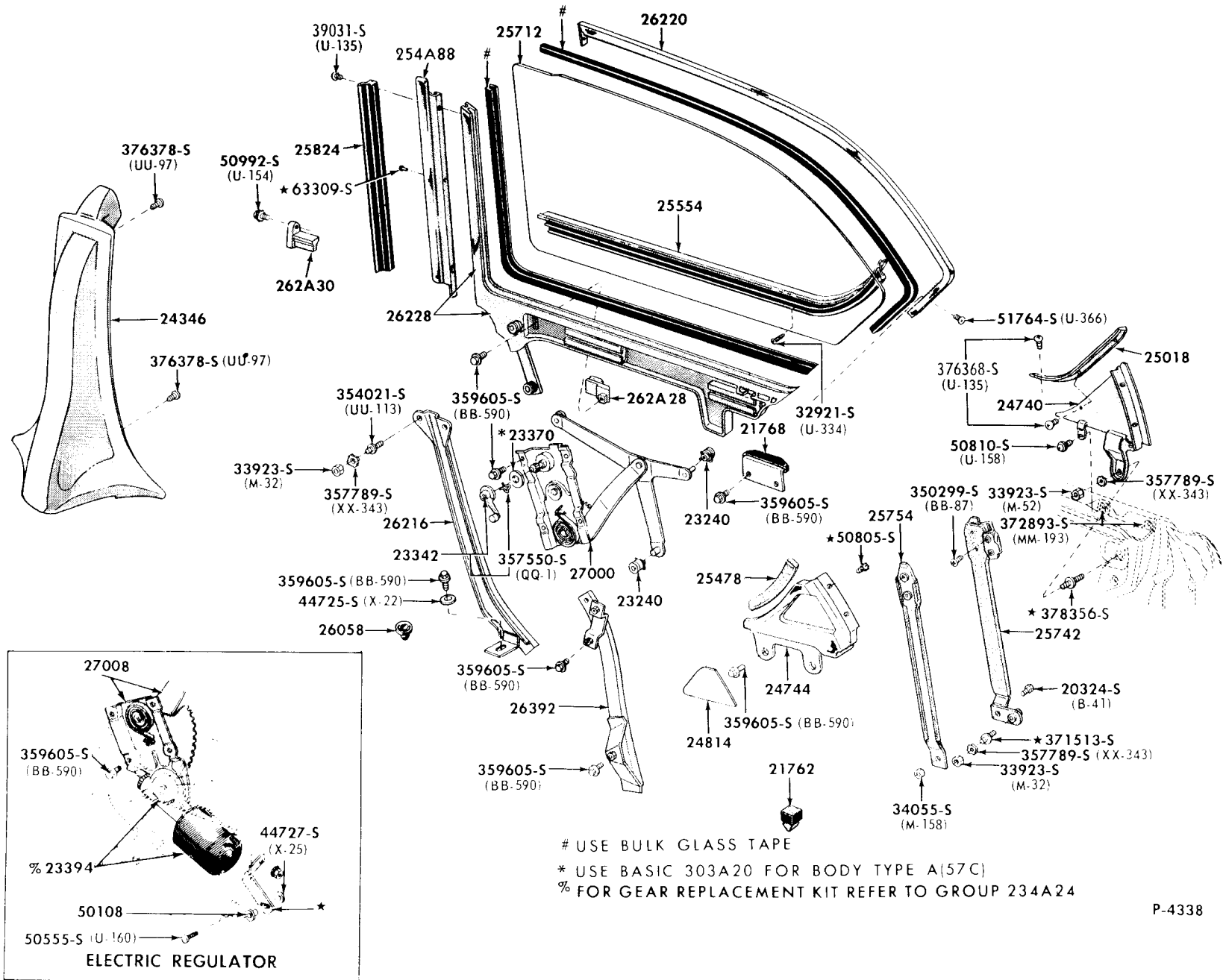

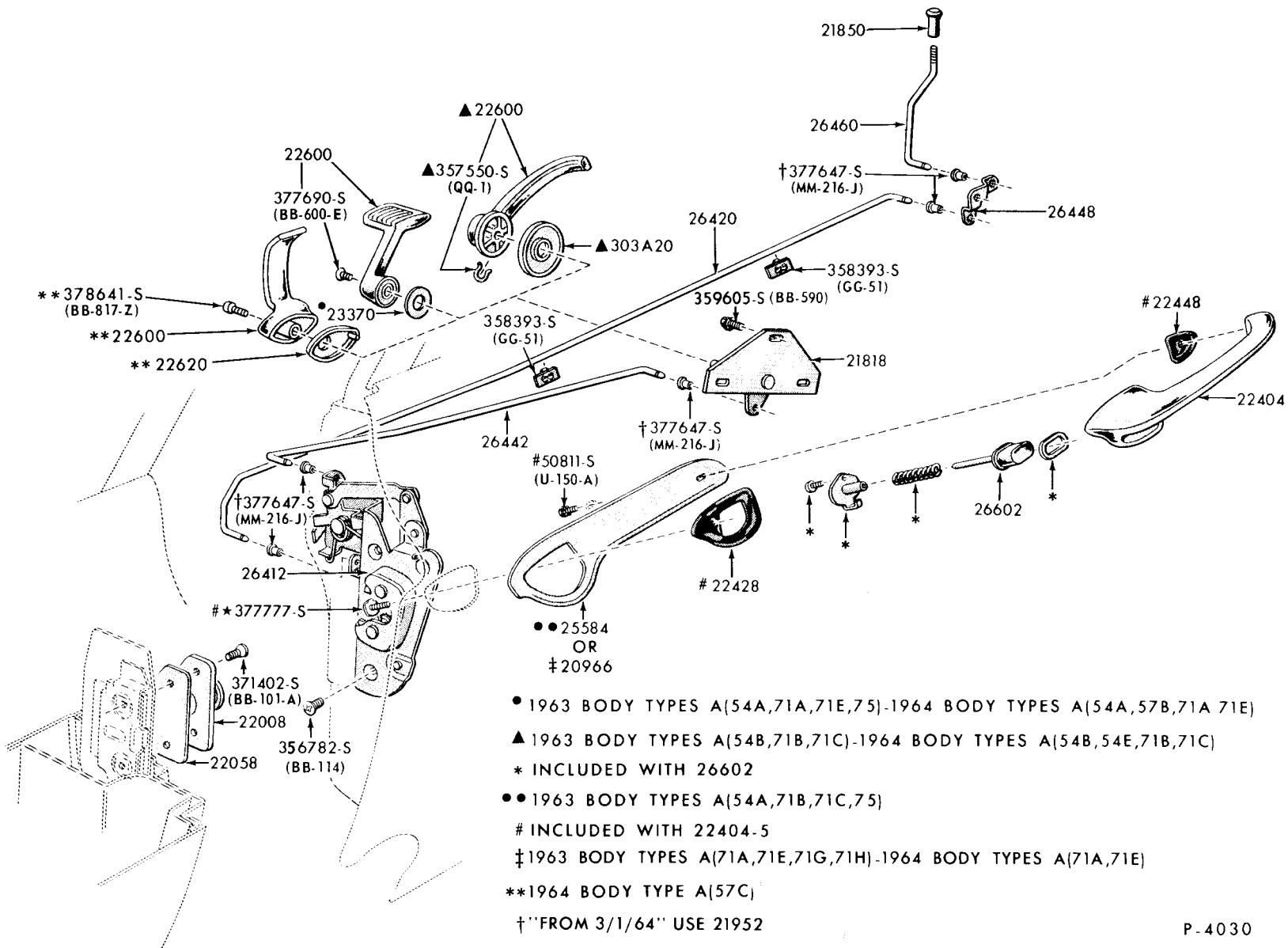

● 1963 BODY TYPES A(54A,71A,71E,75)-1964 BODY TYPES A(54A,57B,71A,71E)

▲ 1963 BODY TYPES A(54B,71B,71C)-1964 BODY TYPES A(54B,54E,71B,71C)

* INCLUDED WITH 26602

● ● 1963 BODY TYPES A(54A,71B,71C,75)

INCLUDED WITH 22404-S

† 1963 BODY TYPES A(71A,71E,71G,71H)-1964 BODY TYPES A(71A,71E)

** 1964 BODY TYPE A(57C)

† "FROM 3/1/64" USE 21952

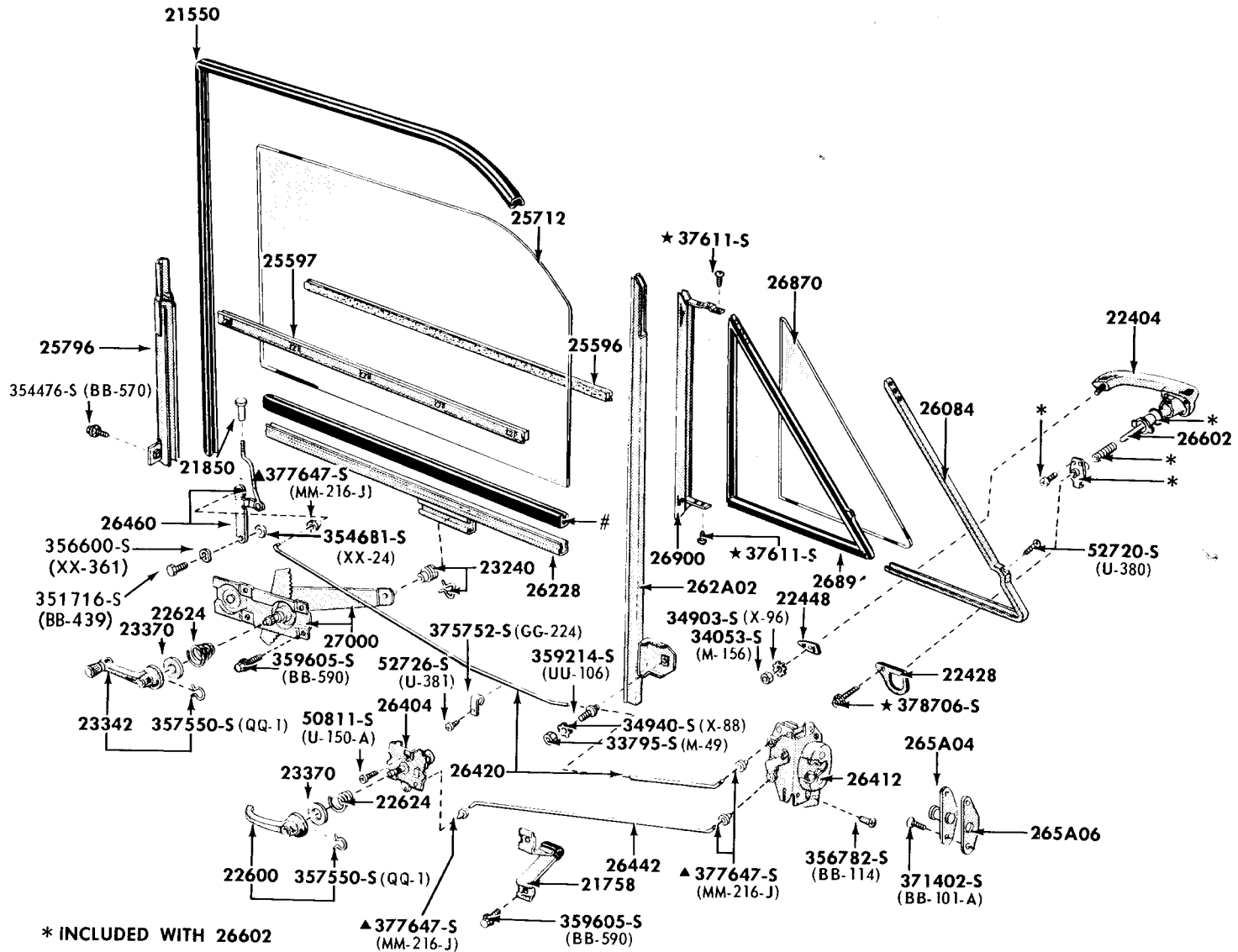

* INCLUDED WITH 26602

USE BULK GLASS TAPE

▲ "FROM 3/1/64" USE 21952

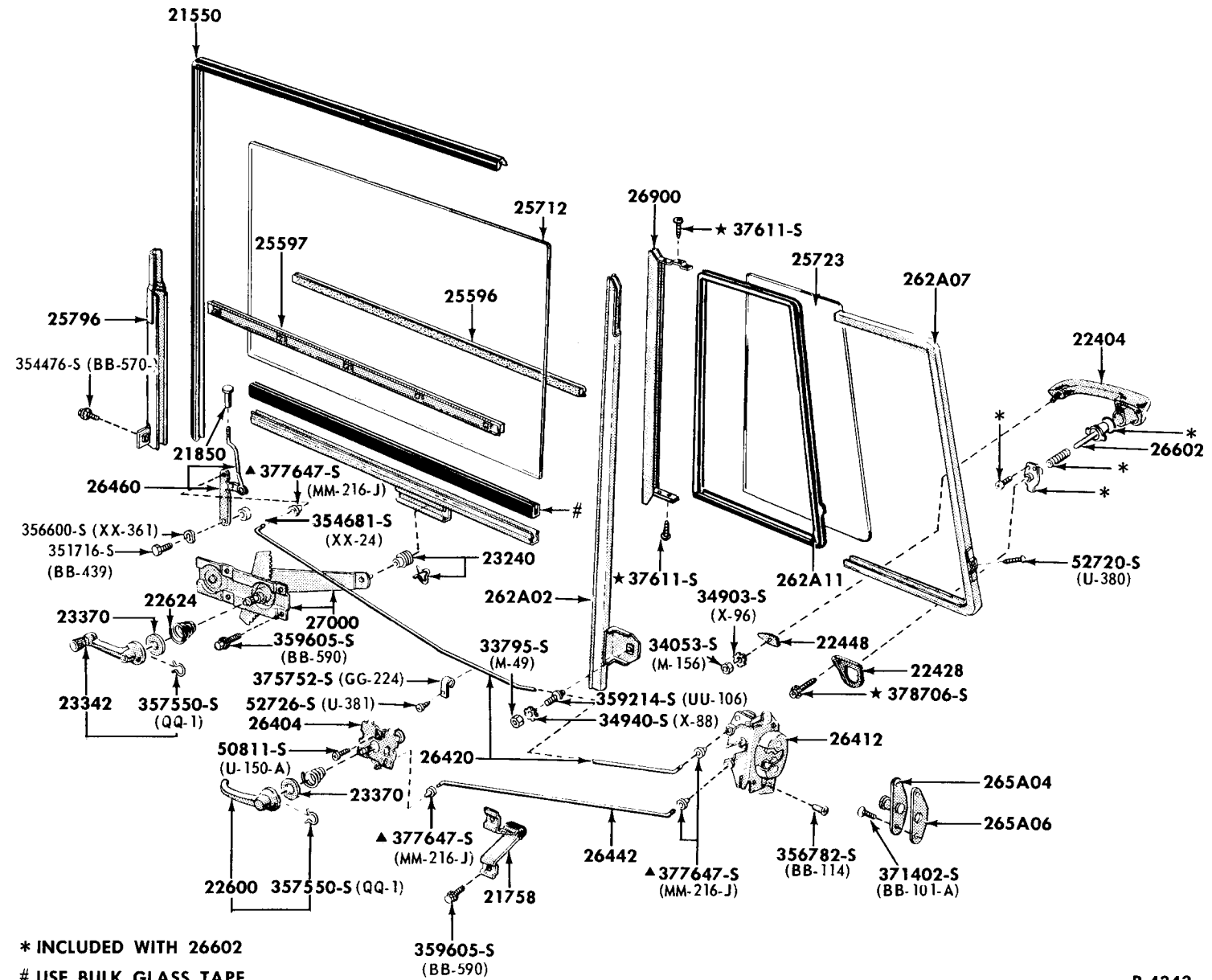

* INCLUDED WITH 26602

USE BULK GLASS TAPE

▲ "FROM 3/1/64" USE 21952

1964 / FALCON REAR DOOR PARTS - BODY TYPE X(71) - TYPICAL

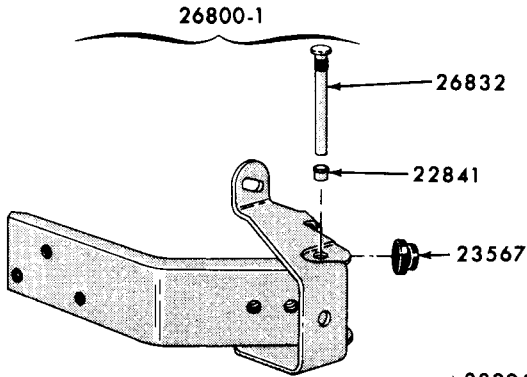

1965 LINCOLN

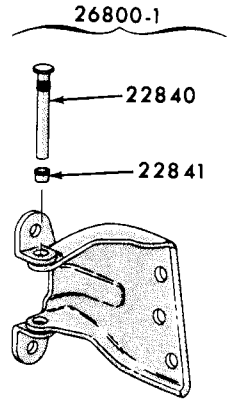

1960/FORD, FAIRLANE/TORINO,
FALCON, MERCURY AND
COMET/MONTEGO

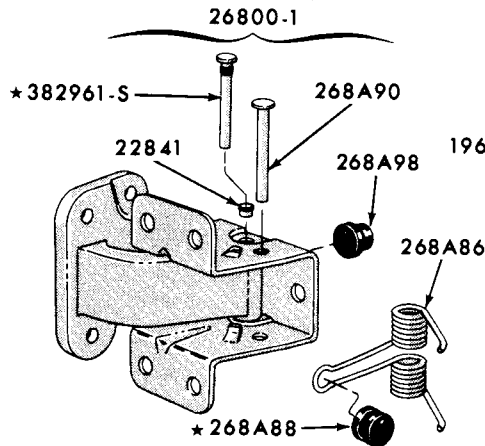

1966/THUNDERBIRD AND LINCOLN

REAR DOOR HINGE - UPPER
1960/ FAIRLANE, FALCON and FORD-TYPICAL

P-6982

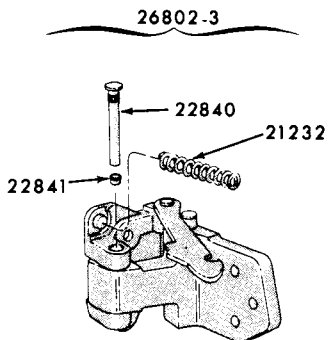

1960/63 FORD, 1965/68 FORD AND
MERCURY, 1965 FAIRLANE
1960/65 FALCON, 1965/67 COMET

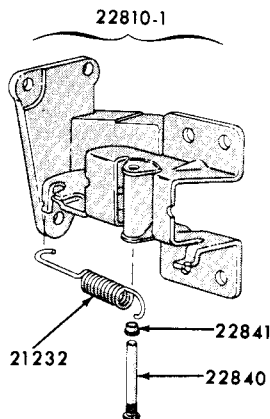

1962/64 FAIRLANE

REAR DOOR HINGE - LOWER
1960/ FAIRLANE, FALCON and FORD-TYPICAL

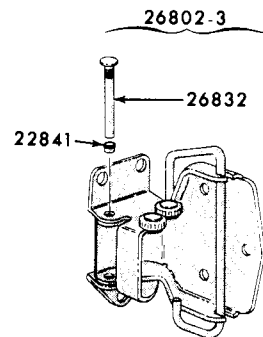

1964 FORD
1969 FORD AND MERCURY,
1960/FAIRLANE/TORINO,
FALCON AND THUNDERBIRD
1968/COMET/MONTEGO,
1965/LINCOLN

P-6983

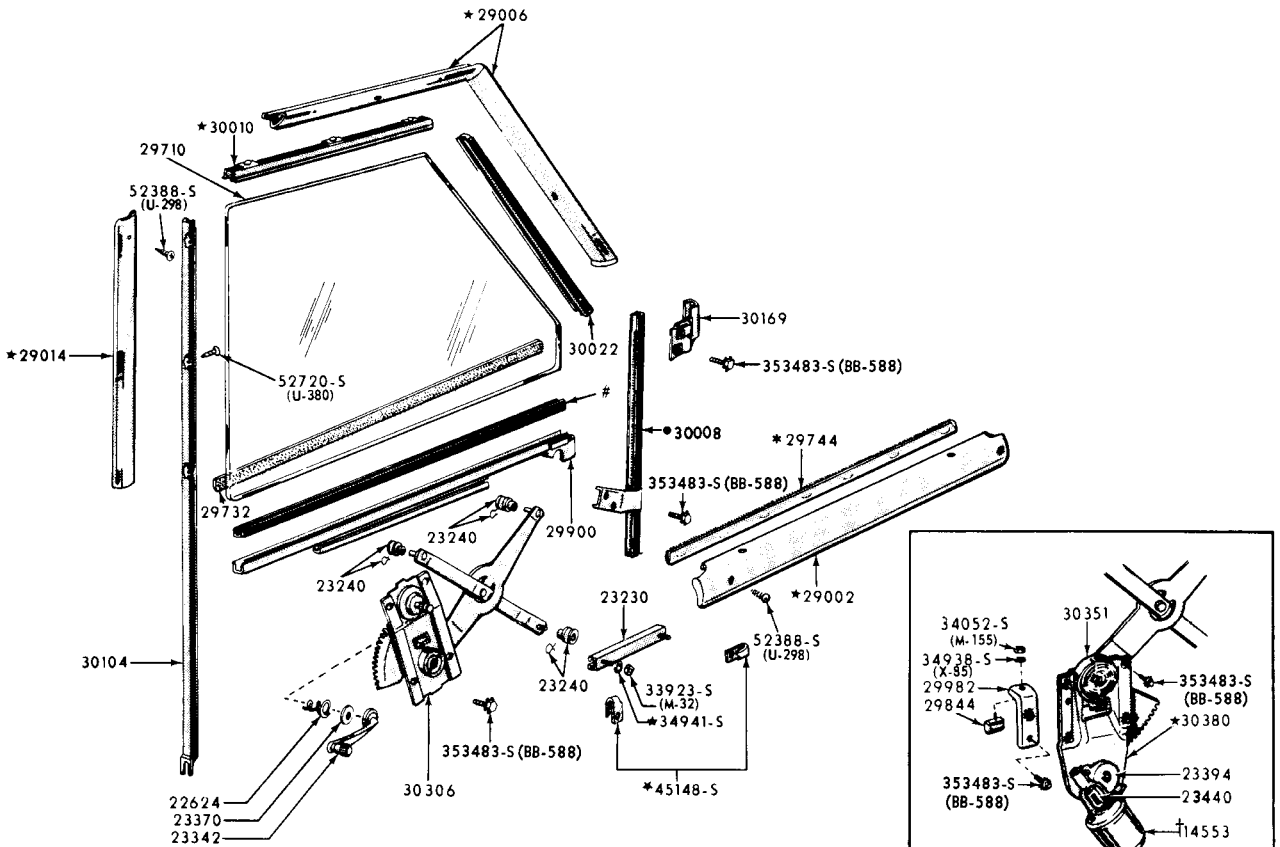

USE BULK GLASS TAPE
 * ALSO INCLUDED IN 29002-3
 ● 1961 ONLY
 † REFER TO GROUP IN CHASSIS SECTION

ELECTRIC REGULATOR

P-3033

1960/61 FRONT QUARTER WINDOW PARTS -BODY TYPE A(59C)

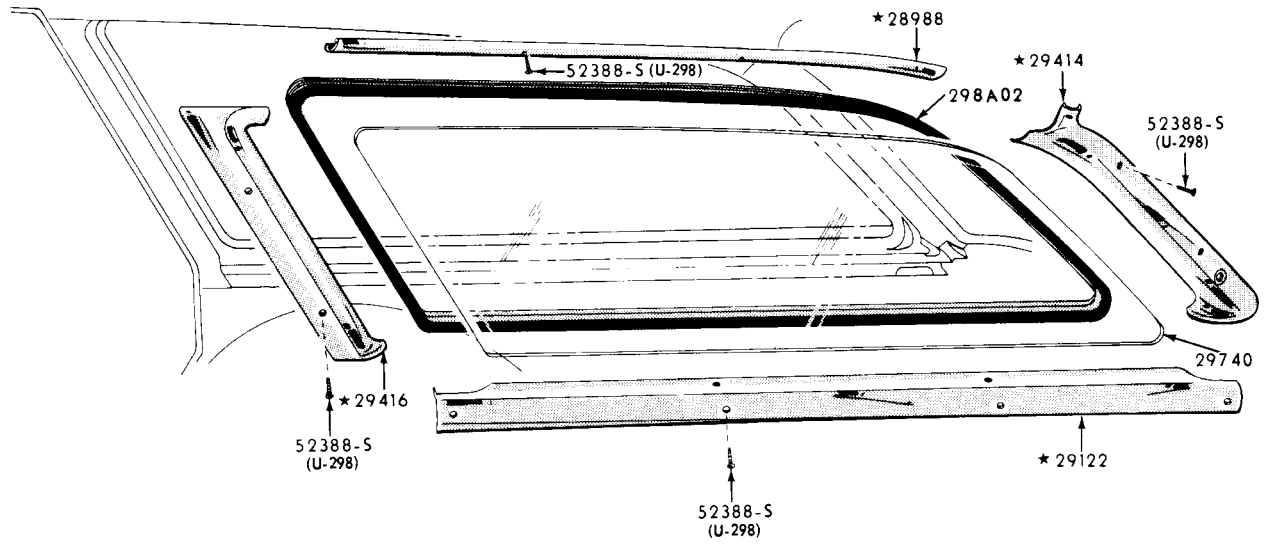

P-3035

1960 REAR QUARTER WINDOW PARTS -BODY TYPES A(59,71)

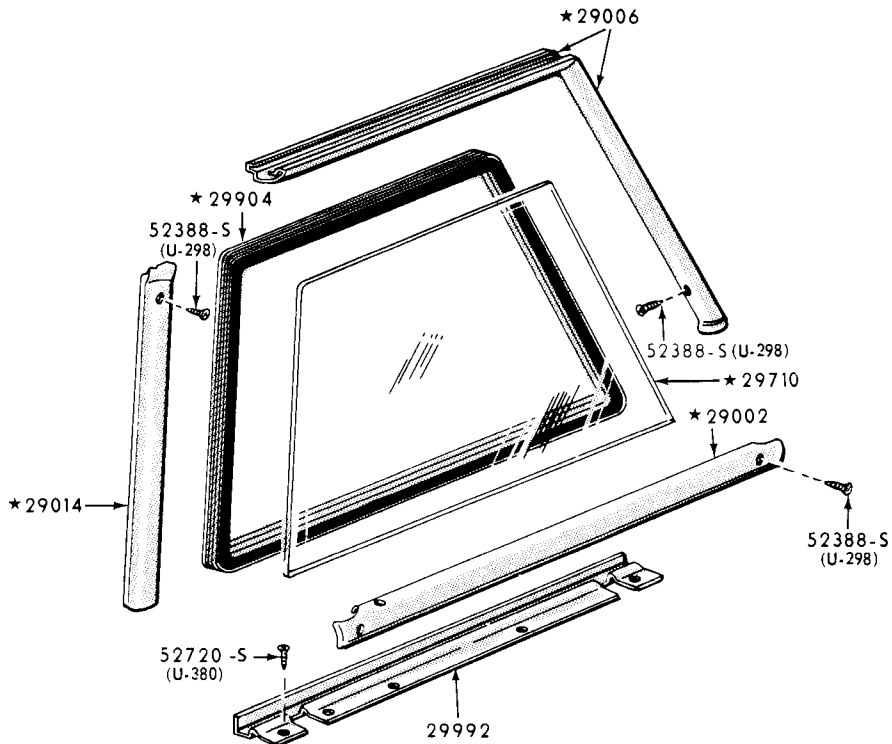

BODY TYPE 59E

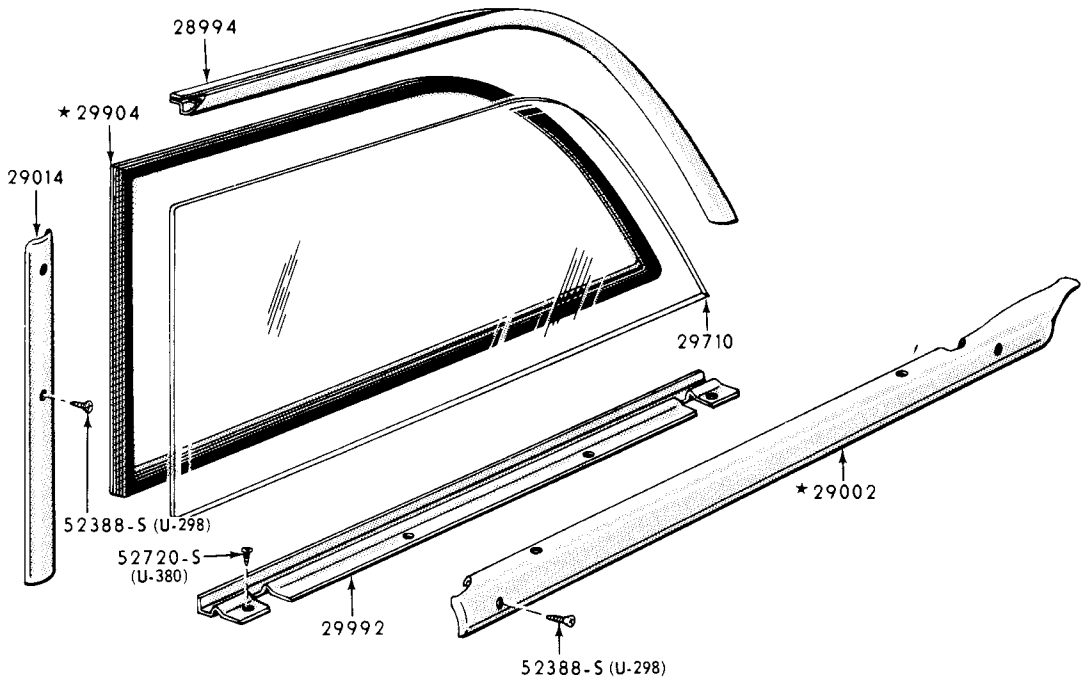

BODY TYPES 64G, 64H

P-3031

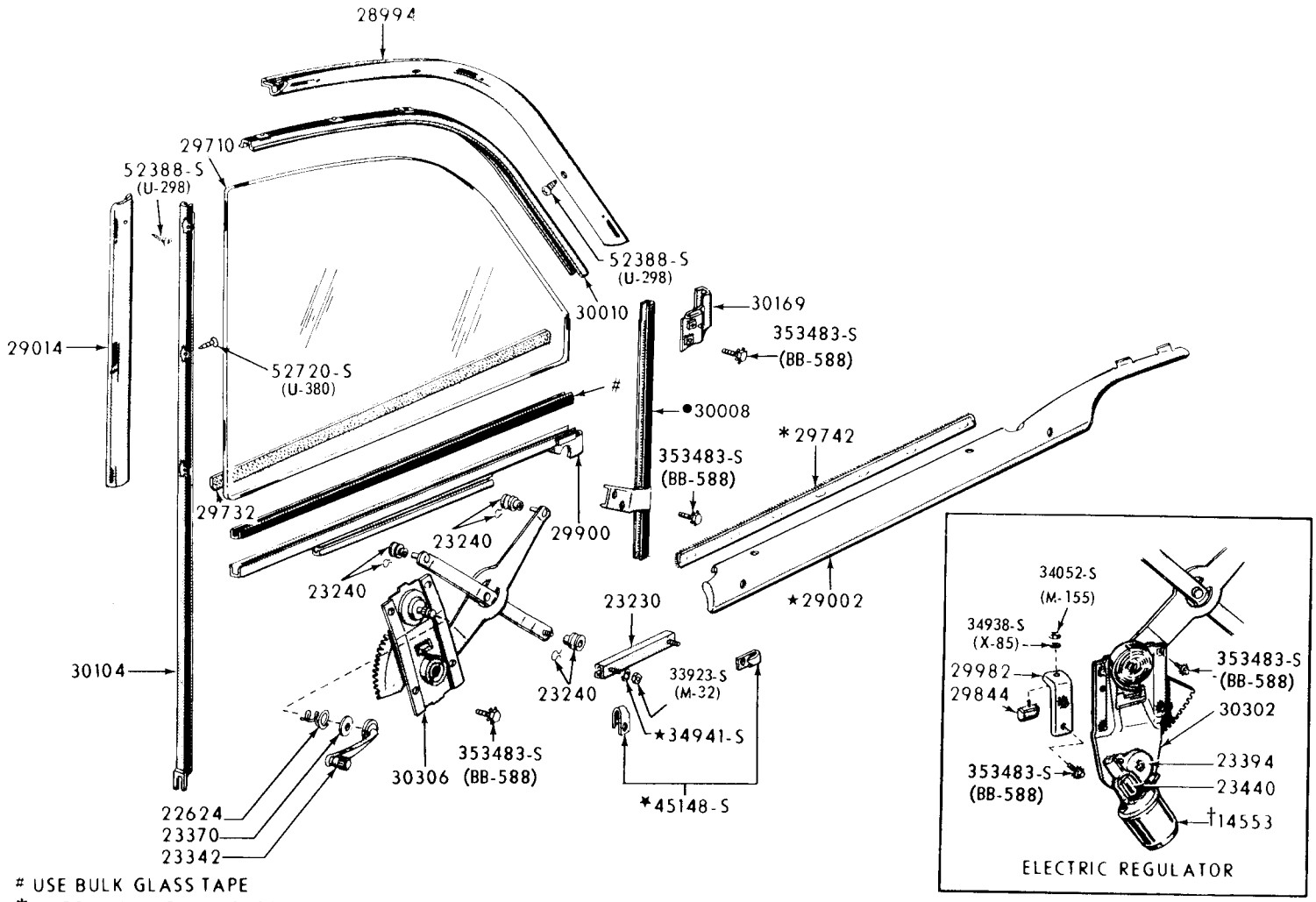

1960/61 QUARTER WINDOW PARTS - BODY TYPES A(62A,64A,64F)

- # USE BULK GLASS TAPE
- * ALSO INCLUDED IN 29002-3
- ▲ 1960 ONLY
- 1961 ONLY
- † REFER TO GROUP IN CHASSIS SECTION

P-3030

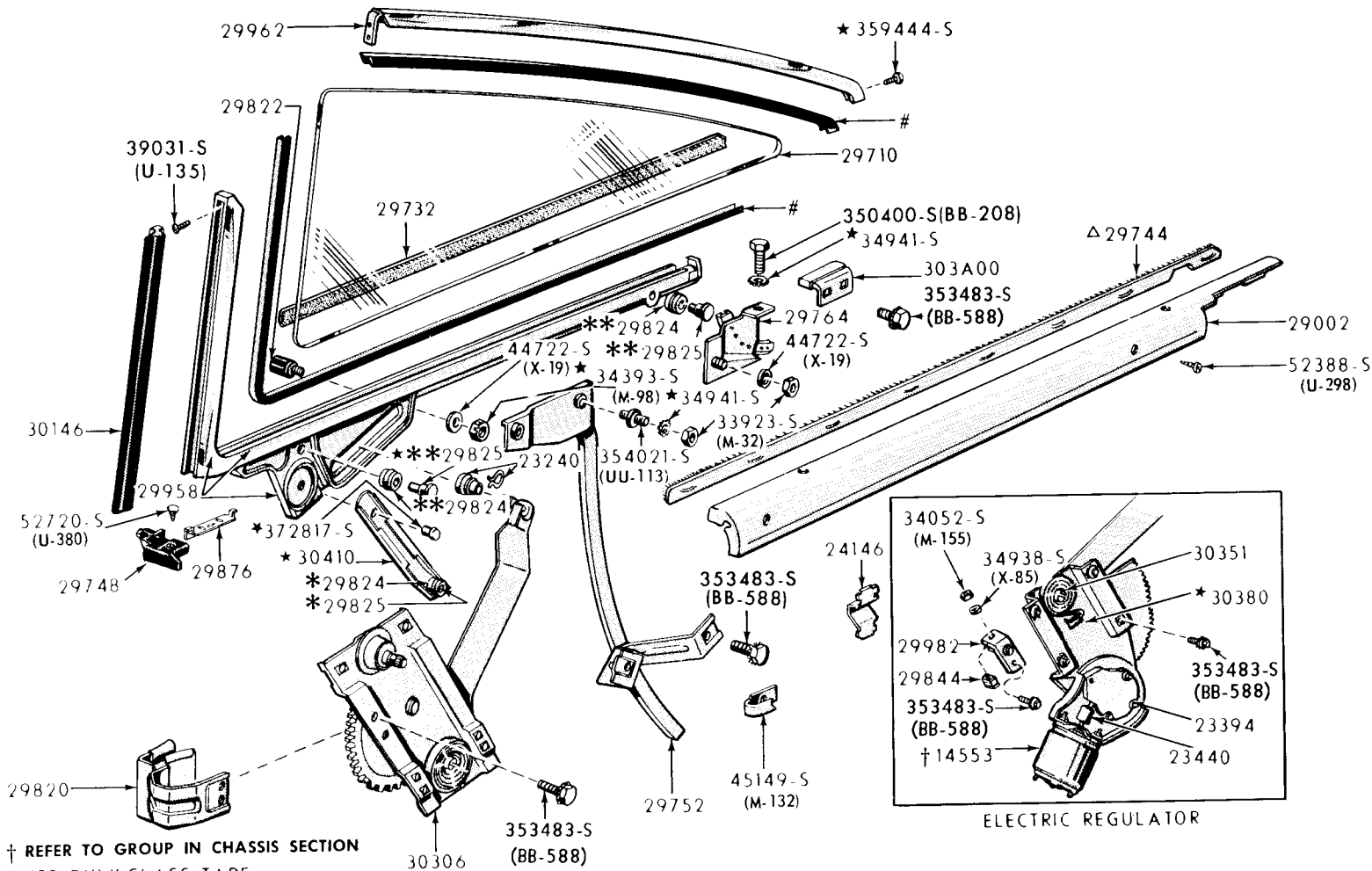

† REFER TO GROUP IN CHASSIS SECTION
USE BULK GLASS TAPE
* ALSO INCLUDED IN 30410
** ALSO INCLUDED IN 29958-9
Δ ALSO INCLUDED IN 29002-3

1960/61 QUARTER WINDOW PARTS-BODY TYPE A(78B)-TYPICAL

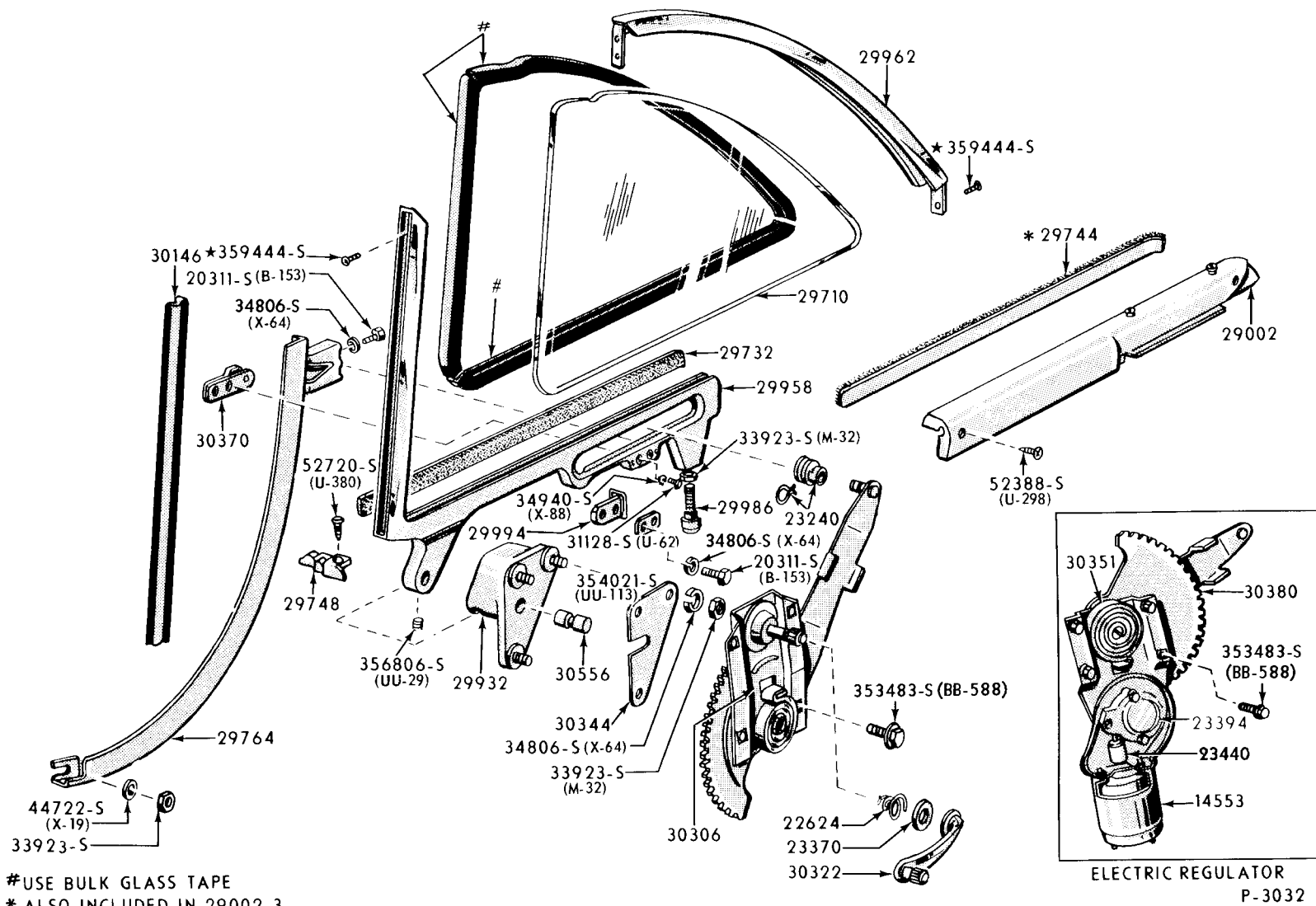

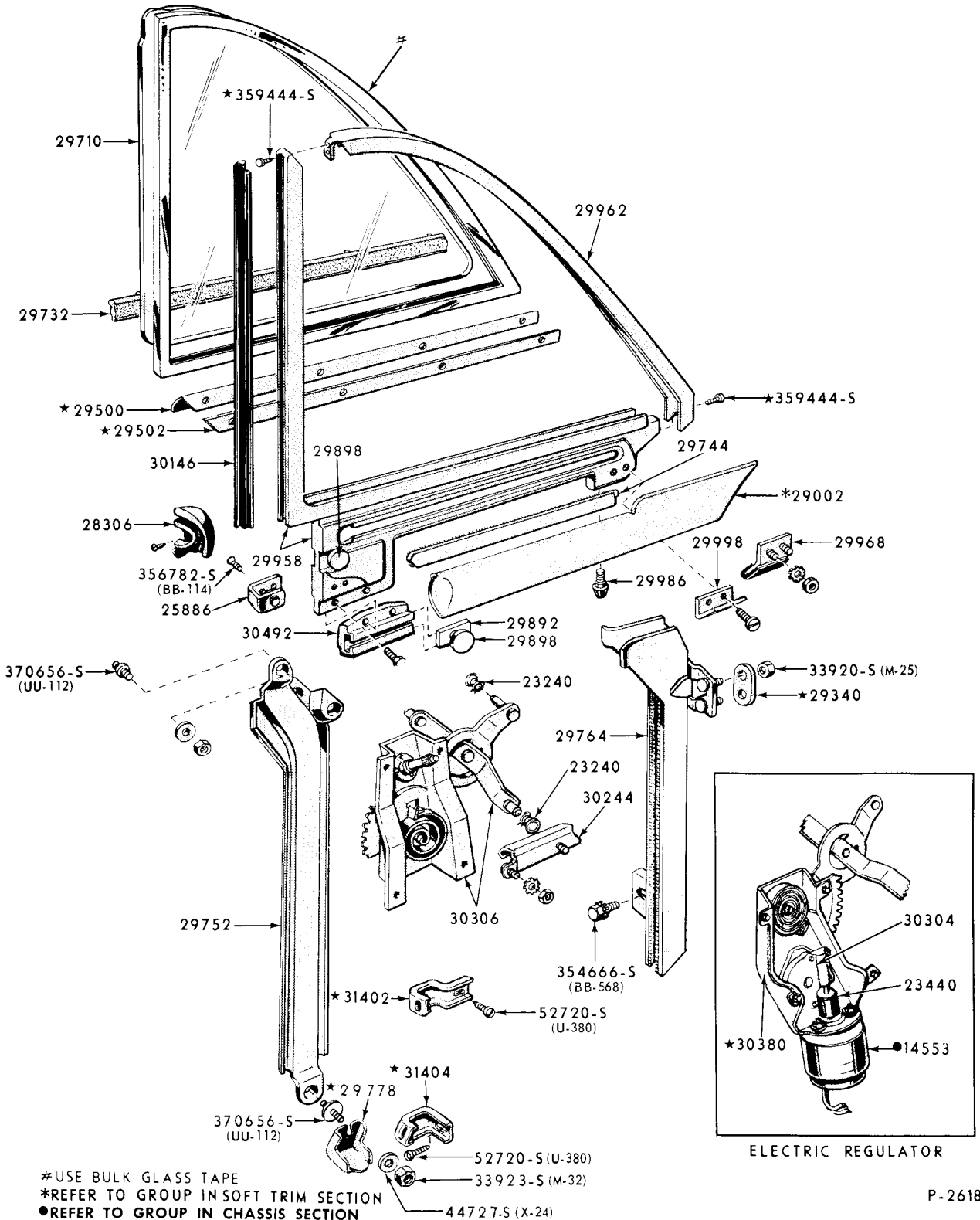

P-2618

1960 / FALCON QUARTER WINDOW PARTS-BODY TYPES X(59A, 62, 64)-TYPICAL

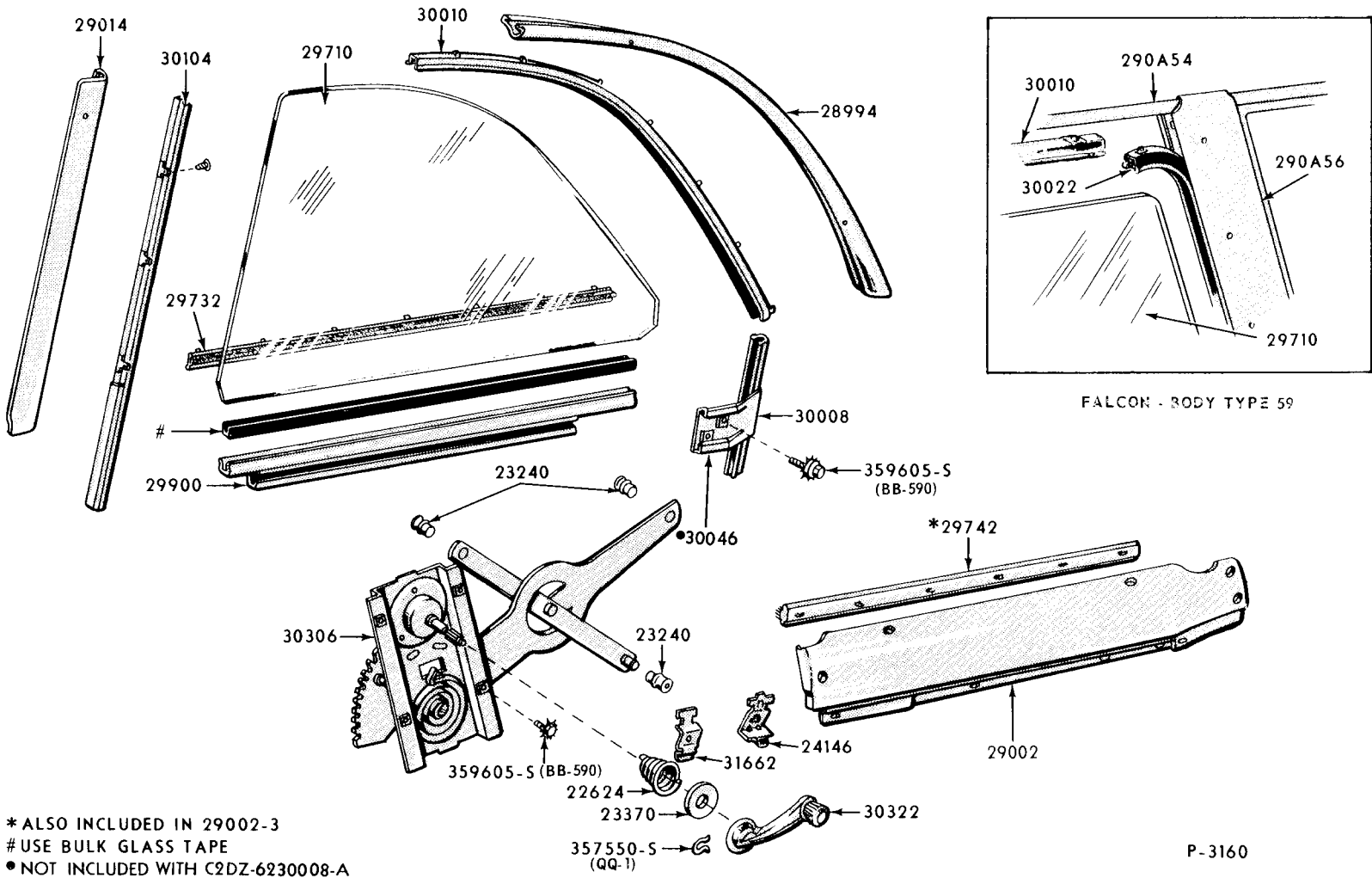

FALCON - BODY TYPE 59

- * ALSO INCLUDED IN 29002-3
- # USE BULK GLASS TAPE
- NOT INCLUDED WITH C2DZ-6230008-A

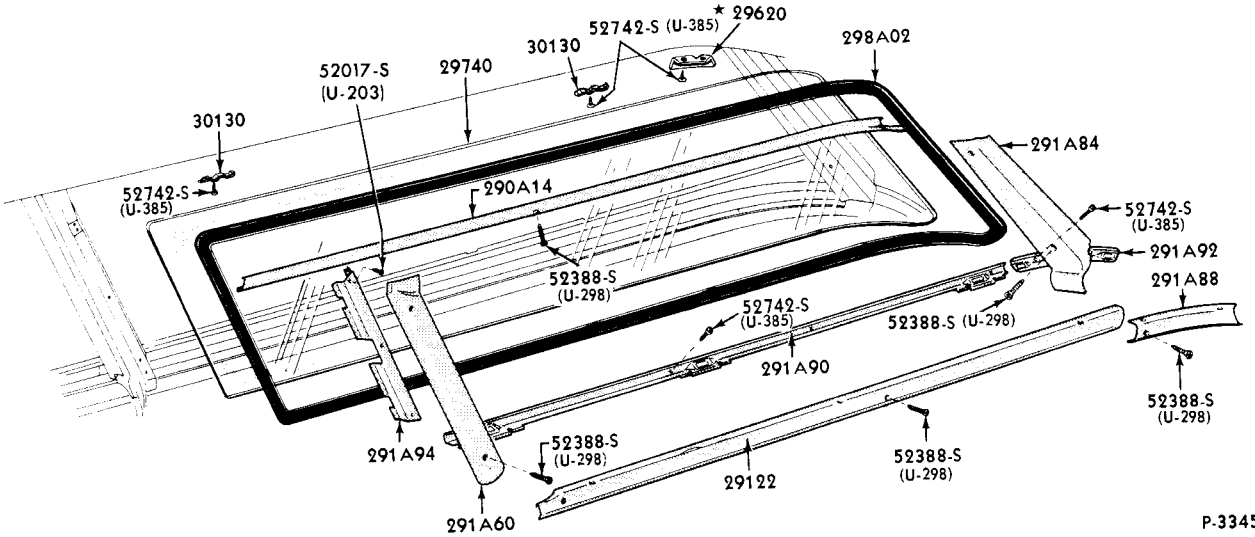

P-3345

1961/64 REAR QUARTER WINDOW PARTS - BODY TYPES A(59, 71)-TYPICAL

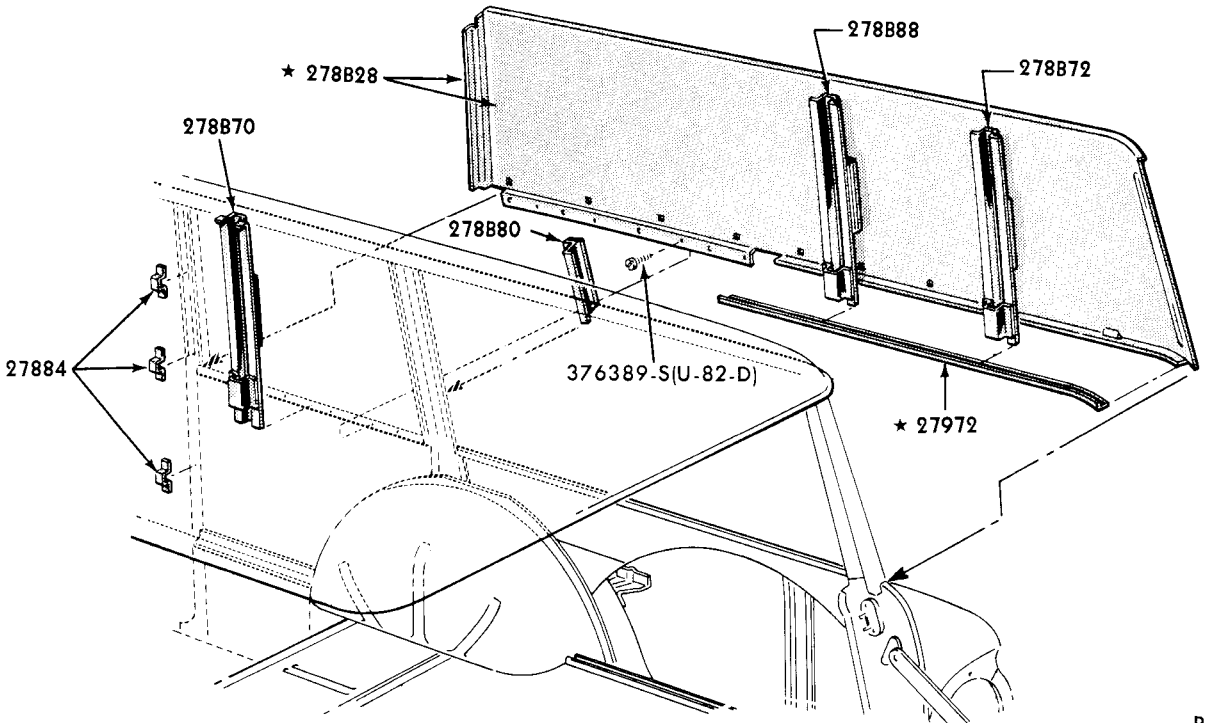

P-3593

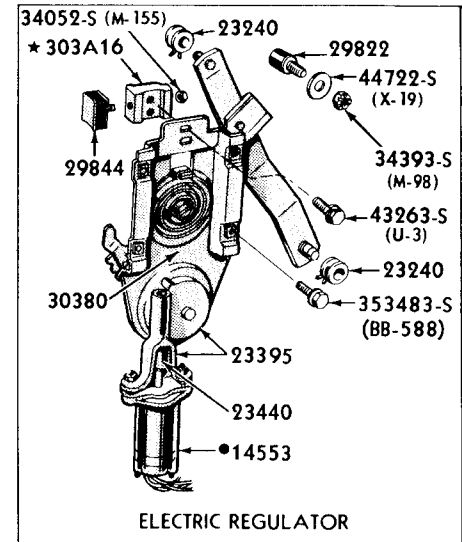
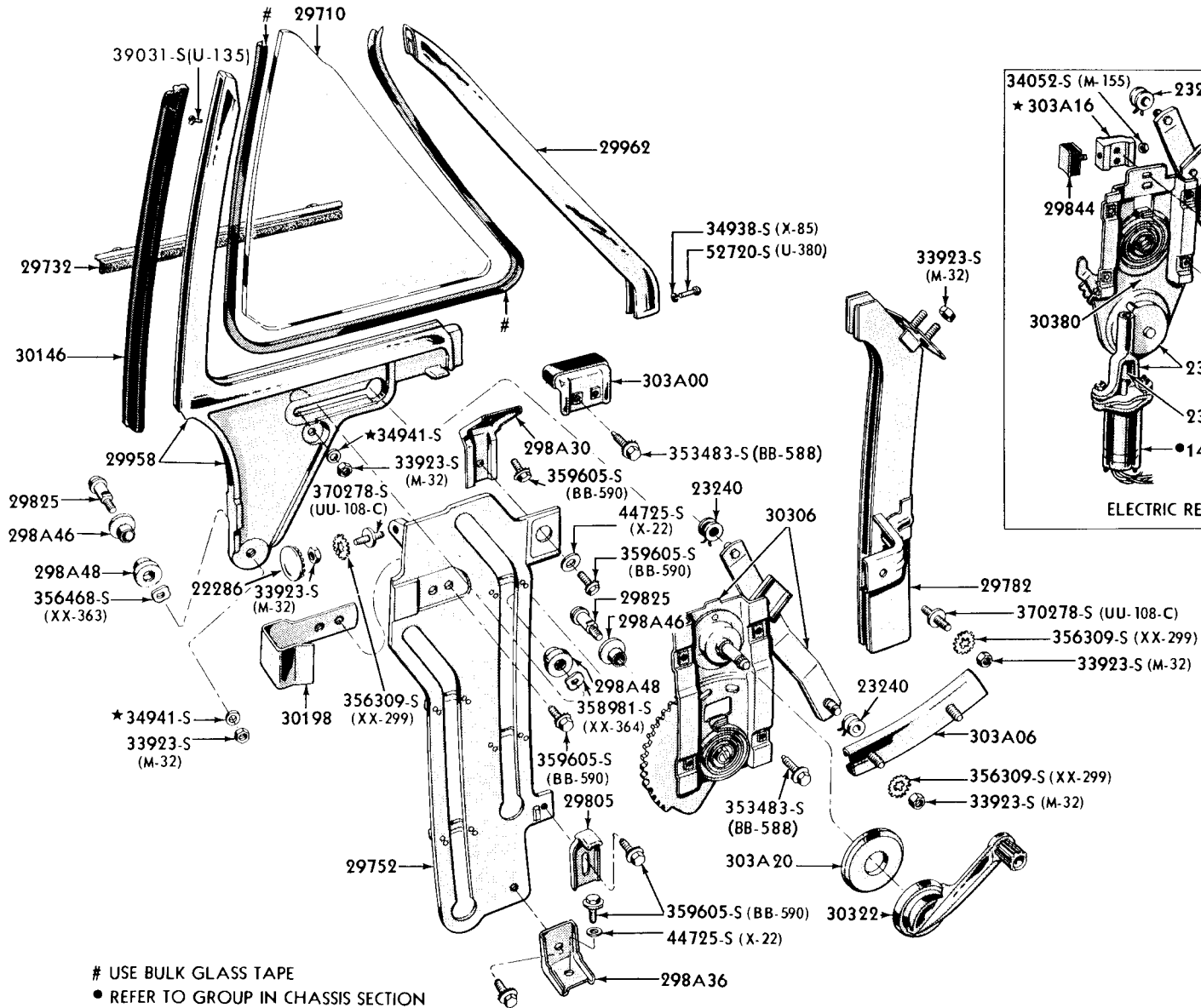

1962/63 QUARTER WINDOW & RELATED PARTS - BODY TYPE A (62)

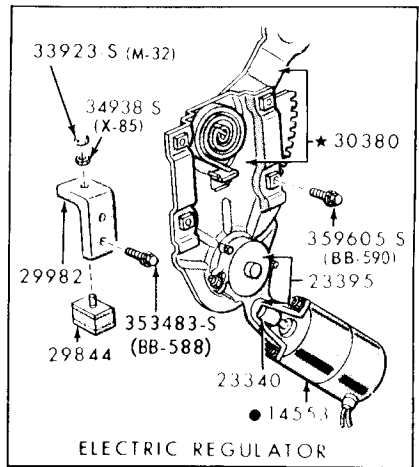
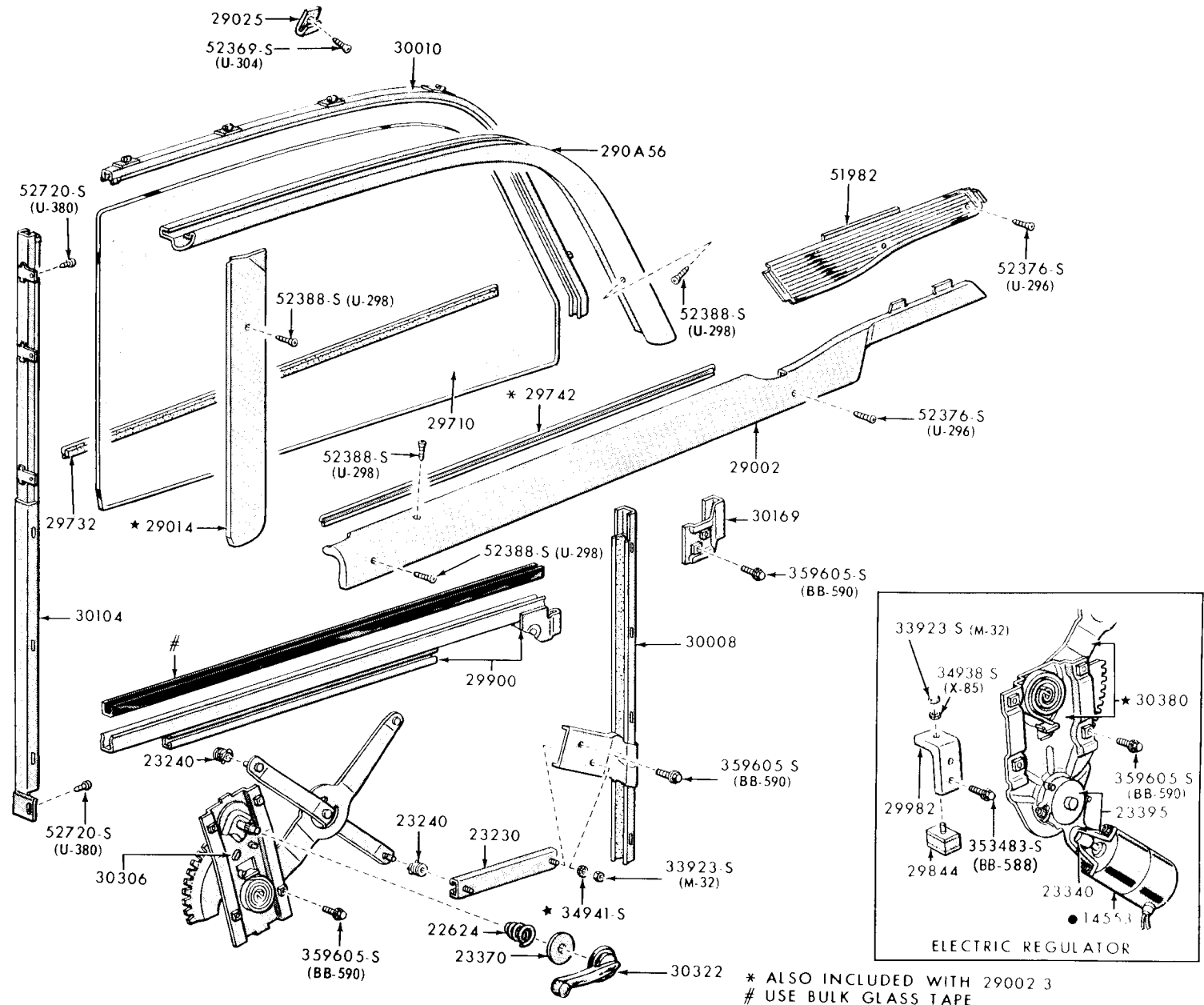

- * ALSO INCLUDED WITH 29002 3
- # USE BULK GLASS TAPE
- REFER TO GROUP IN CHASSIS SECTION

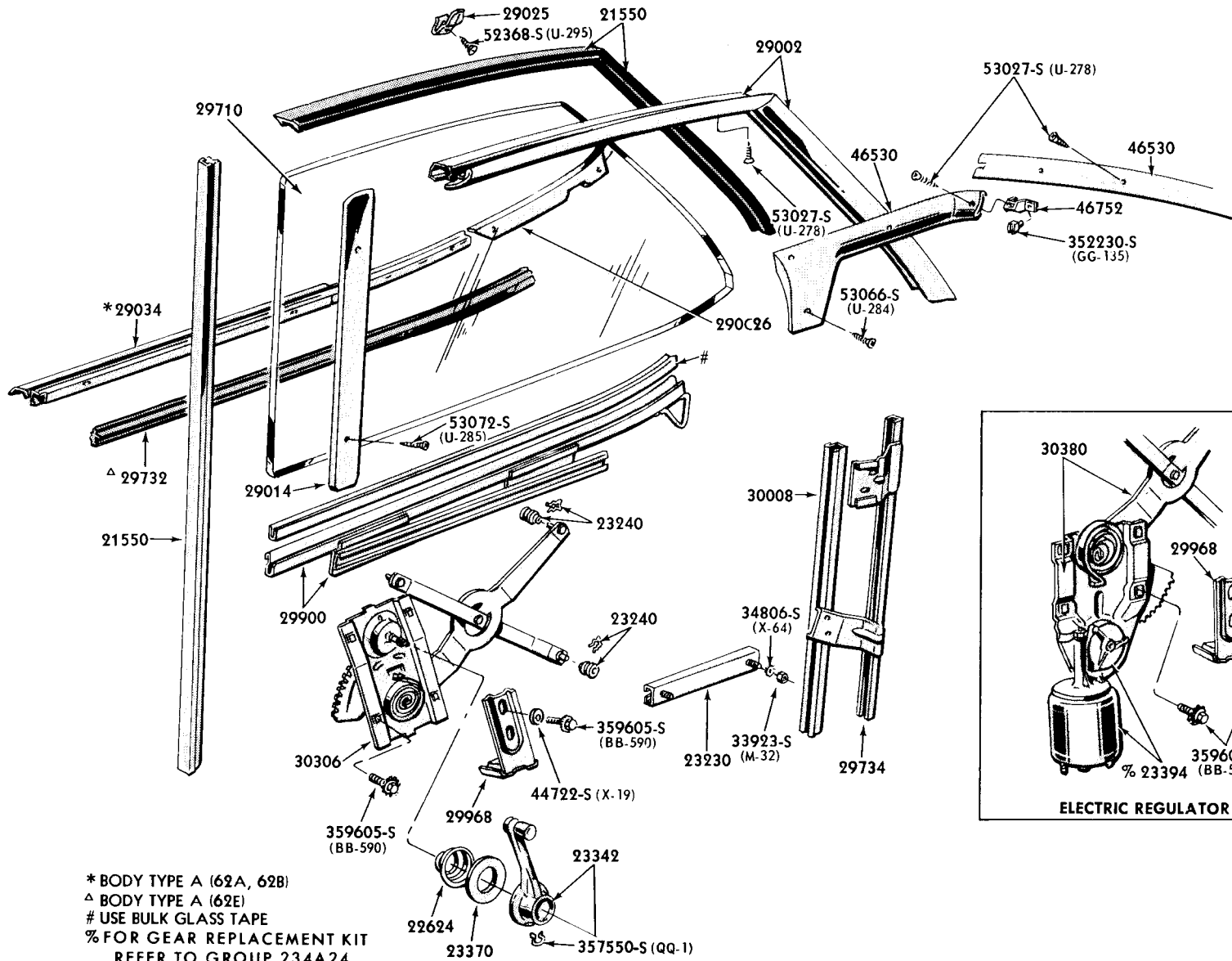

* BODY TYPE A (62A, 62B)
 Δ BODY TYPE A (62E)
 # USE BULK GLASS TAPE
 % FOR GEAR REPLACEMENT KIT
 REFER TO GROUP 234A24

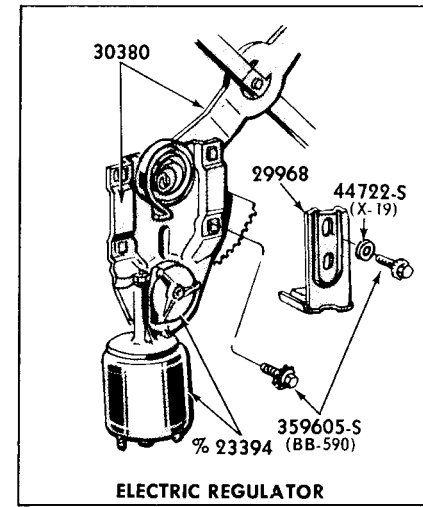

1963 QUARTER WINDOW & RELATED PARTS - BODY TYPE A(63)

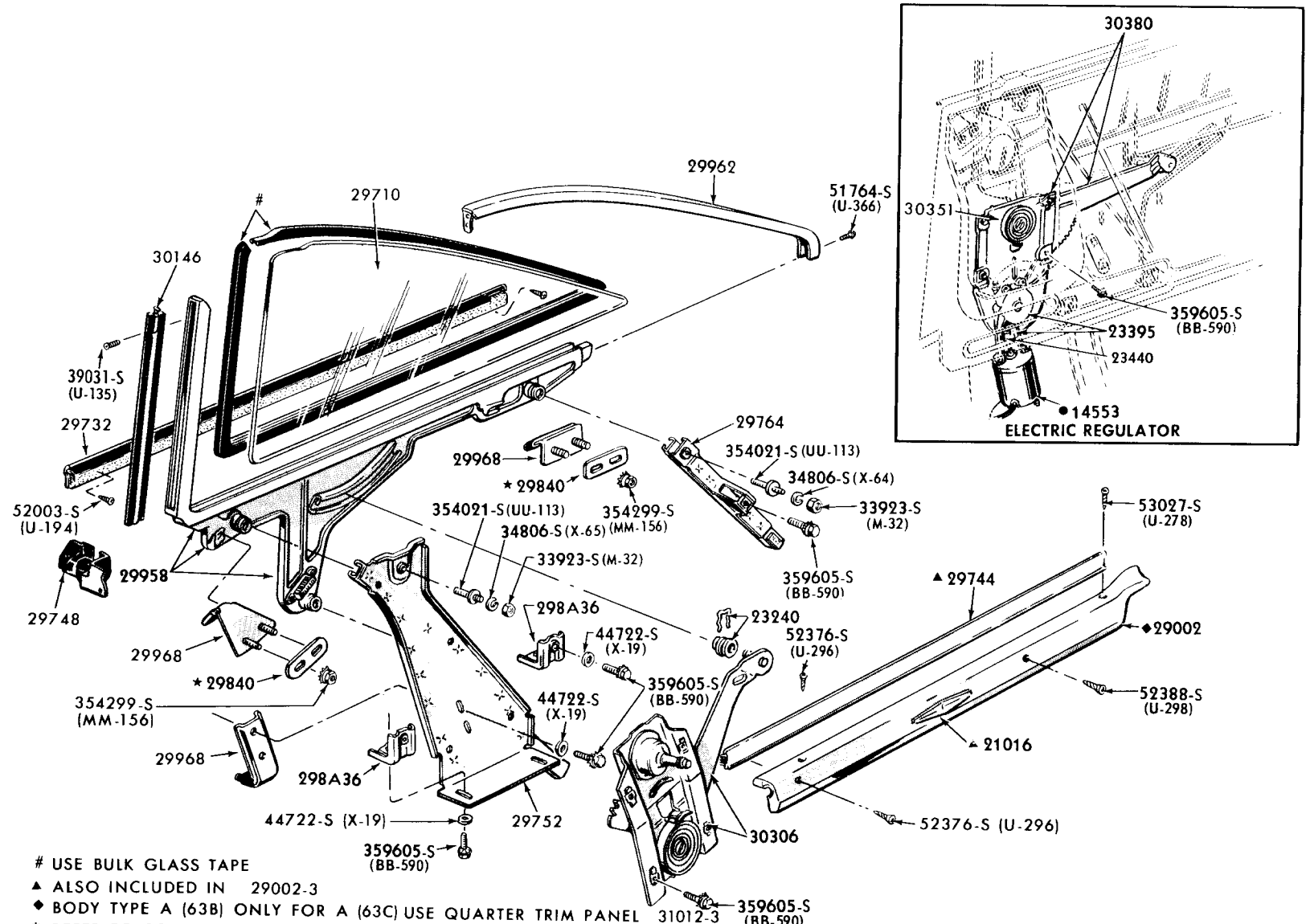

- # USE BULK GLASS TAPE
- ▲ ALSO INCLUDED IN 29002-3
- ◆ BODY TYPE A (63B) ONLY FOR A (63C) USE QUARTER TRIM PANEL 31012-3
- * REFER TO SOFT TRIM SECTION
- REFER TO CHASSIS SECTION GROUP

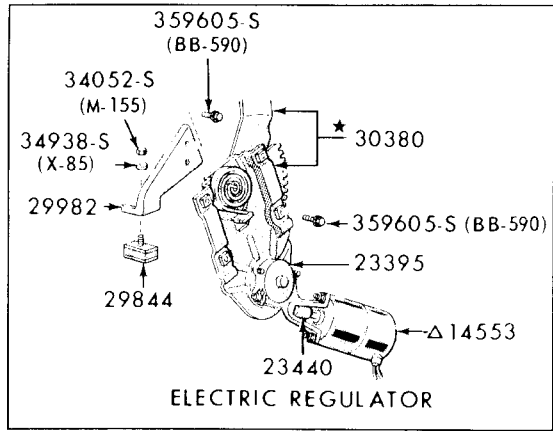
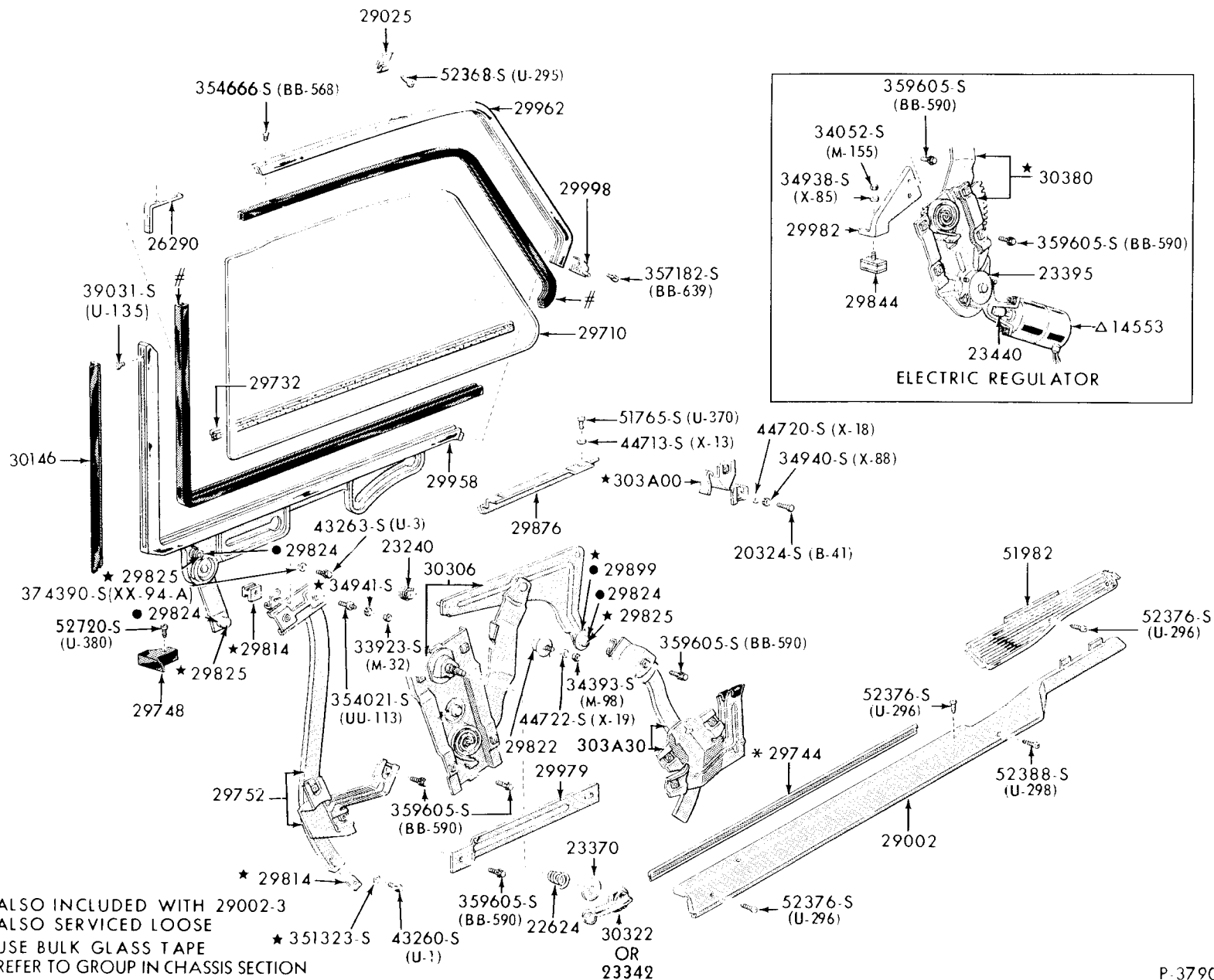

1962/63 QUARTER WINDOW & RELATED PARTS-BODY TYPE A(65) - TYPICAL

- * ALSO INCLUDED WITH 29002-3
- ALSO SERVICED LOOSE
- # USE BULK GLASS TAPE
- △ REFER TO GROUP IN CHASSIS SECTION

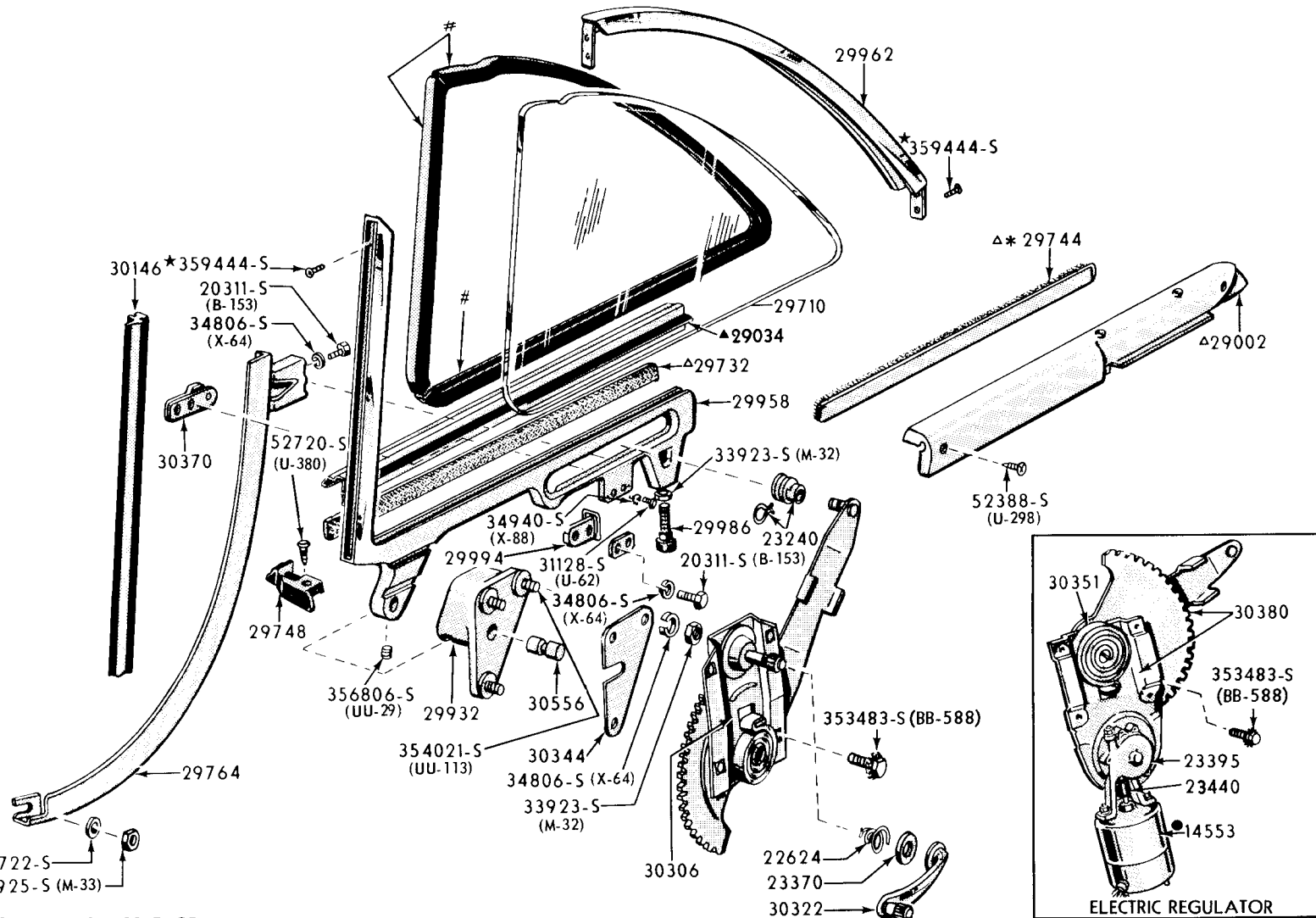

- # USE BULK GLASS TAPE
- * ALSO INCLUDED IN 29002-3
- REFER TO GROUP IN CHASSIS SECTION
- Δ 1962/63 UNITS
- ▲ 1964 UNITS

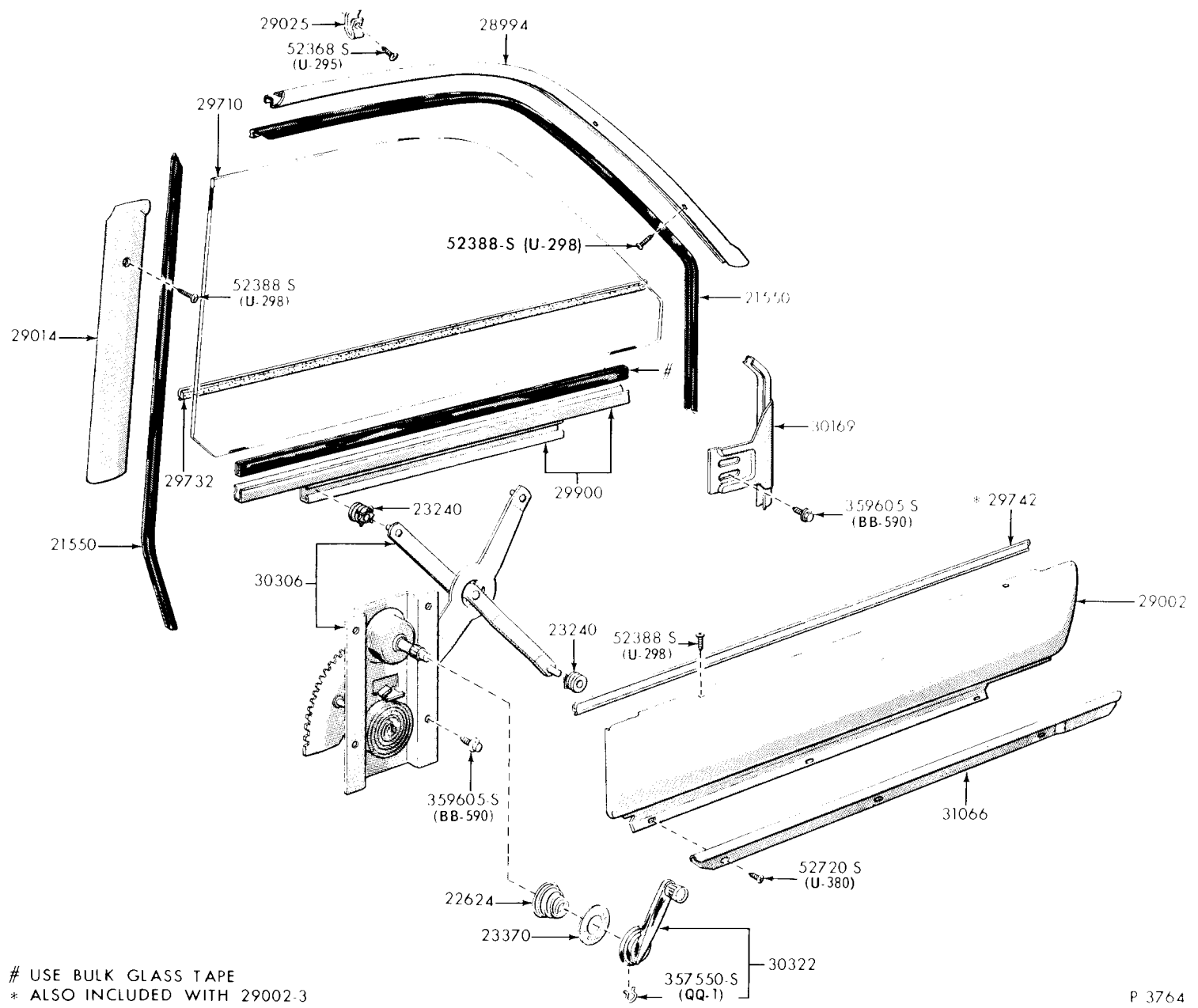

USE BULK GLASS TAPE
* ALSO INCLUDED WITH 29002-3

1962 / FAIRLANE QUARTER WINDOW PARTS-BODY TYPE B(62)-TYPICAL

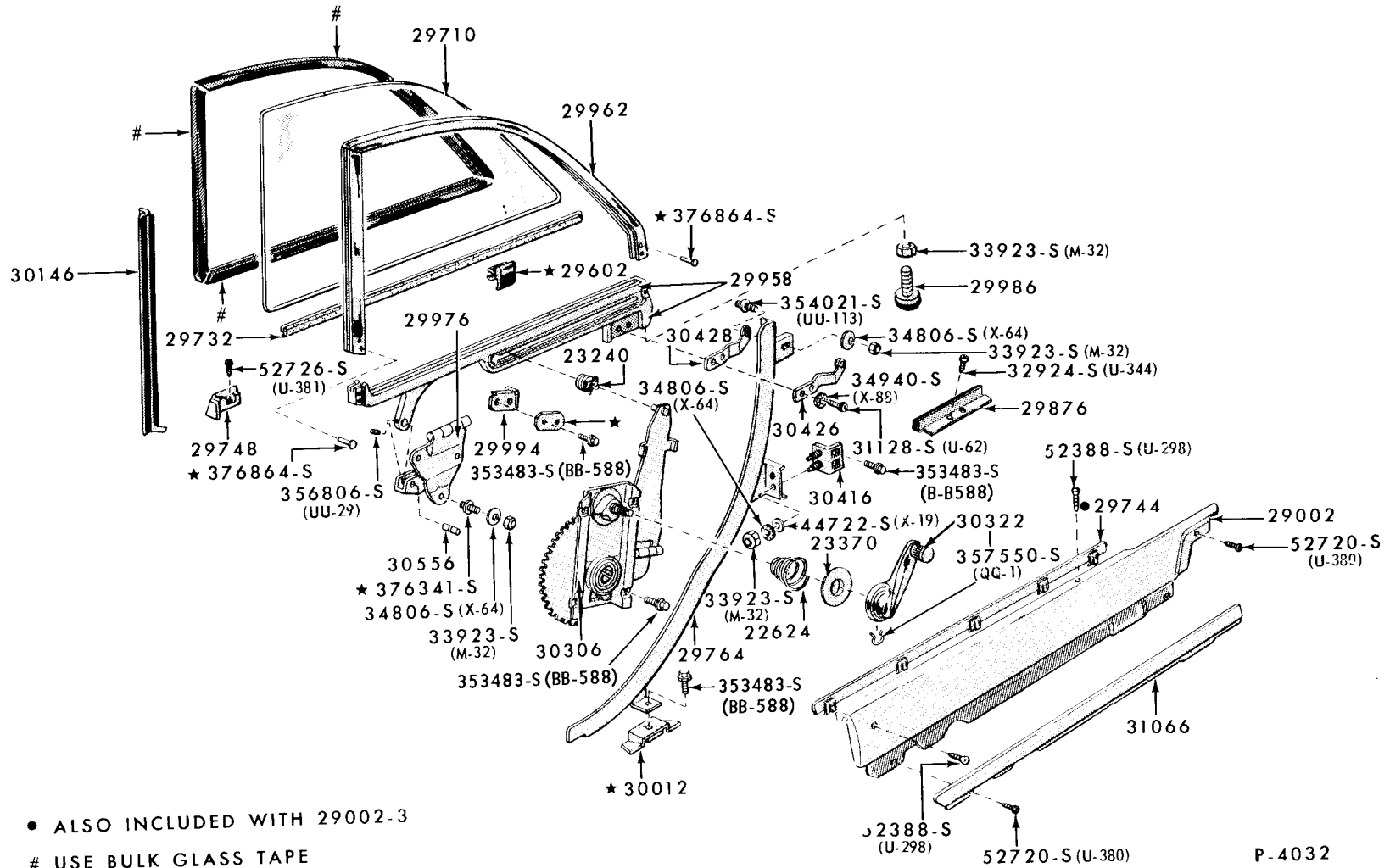

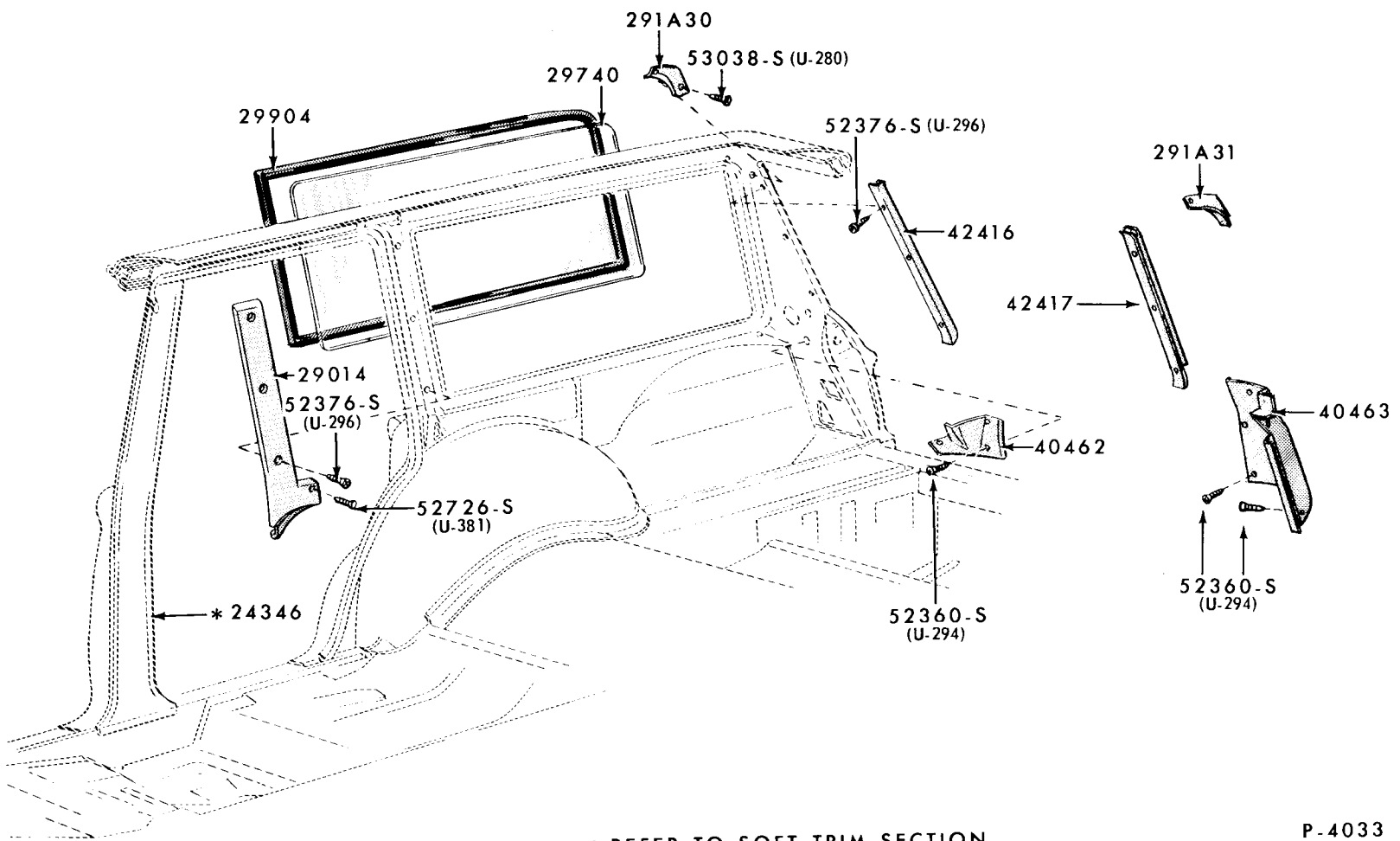

* REFER TO SOFT TRIM SECTION

P-4033

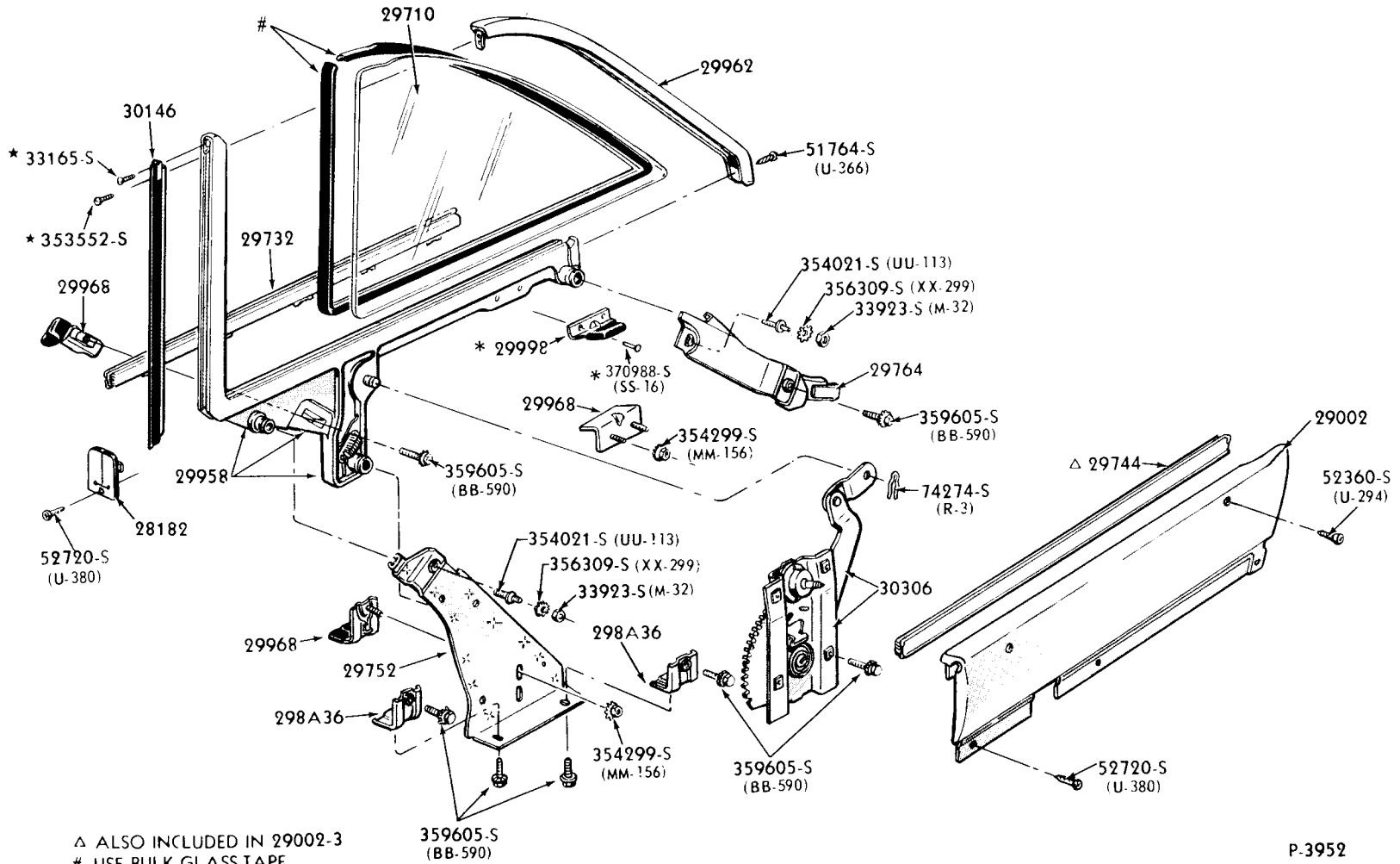

- Δ ALSO INCLUDED IN 29002-3
- # USE BULK GLASS TAPE
- * ALSO INCLUDED IN 29958-9

P-3952

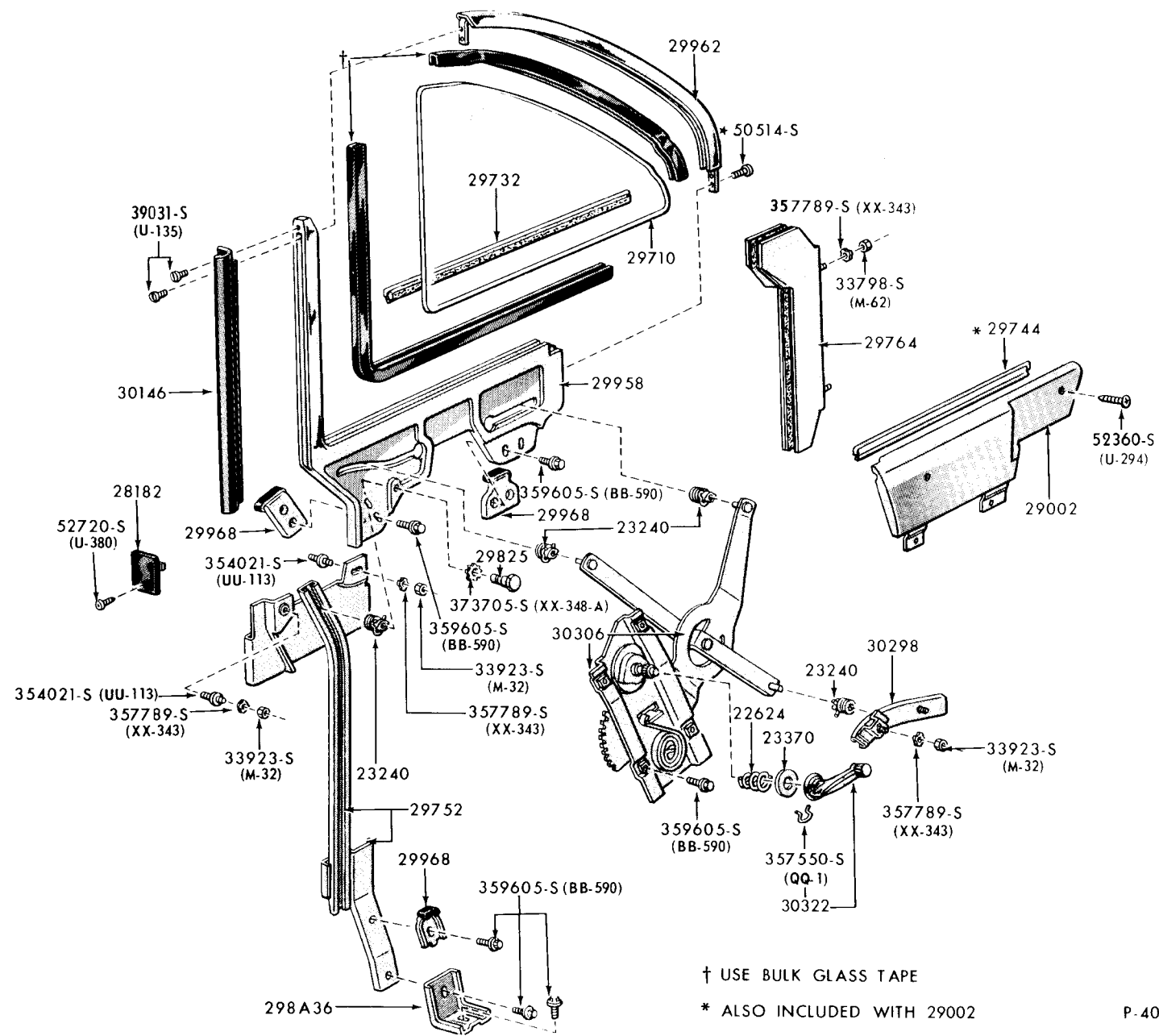

† USE BULK GLASS TAPE

* ALSO INCLUDED WITH 29002

P-4036

1963/ FALCON QUARTER WINDOW & RELATED PARTS - BODY TYPE X (76)

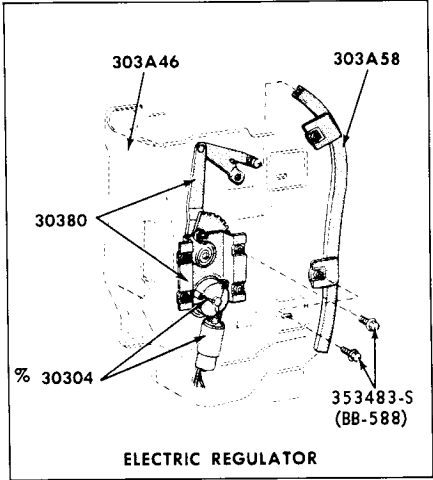
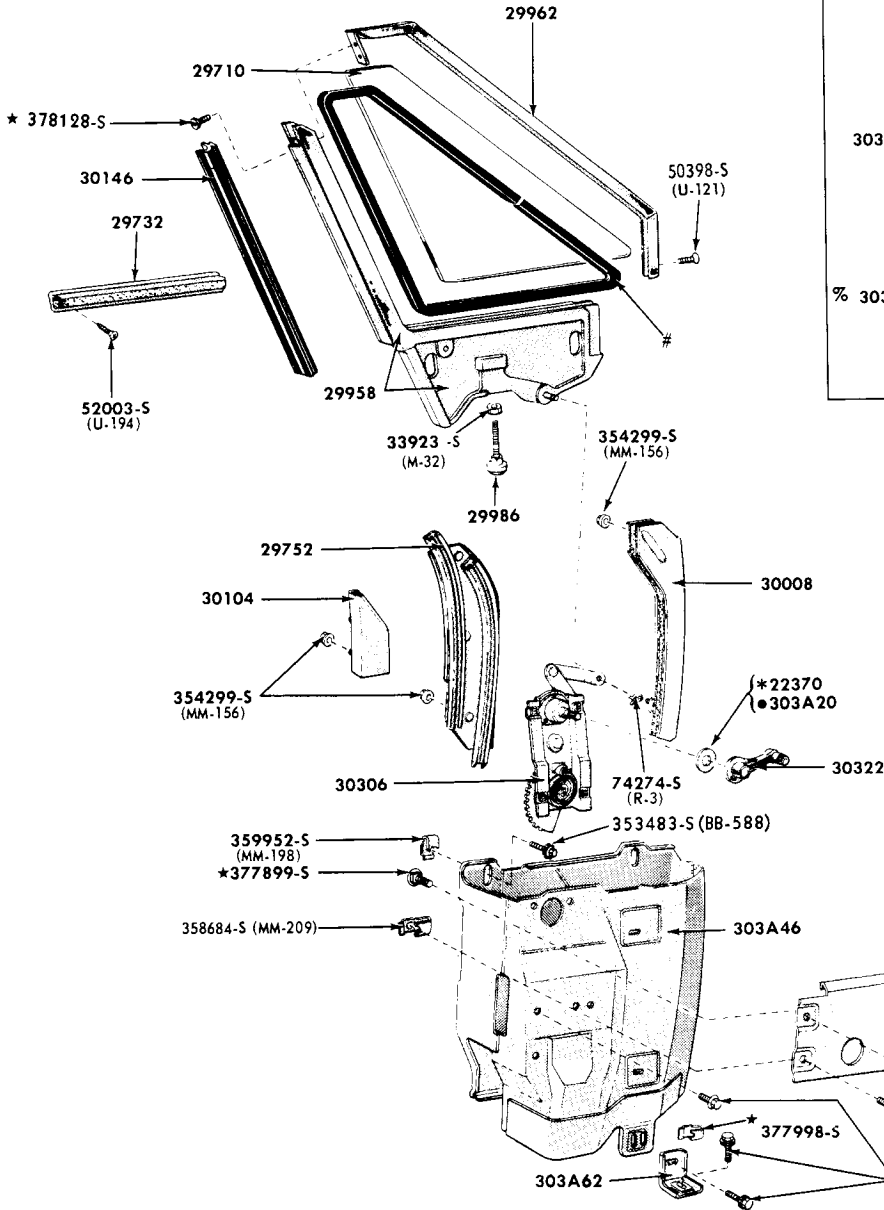

#USE BULK GLASS TAPE

*BODY TYPES S(63A, 76)

●BODY TYPE S(63B)

% FOR GEAR REPLACEMENT KIT REFER TO GROUP 234A24

P-4344

