

**INDEX**

INCLUDED IN THIS INDEX ARE THE FOLLOWING MAJOR GROUPS IN THE ORDER SHOWN BELOW:

- |                                 |                                       |
|---------------------------------|---------------------------------------|
| JACK                            | REAR BUMPER                           |
| SPEEDOMETER                     | REAR VIEW MIRROR                      |
| WINDSHIELD WASHER               | SHOCK ABSORBERS                       |
| WINDSHIELD WIPER                | HEATER                                |
| WINDSHIELD WIPER ELECTRIC MOTOR | AIR CONDITIONER-ENGINE COMPARTMENT    |
| FRONT BUMPER                    | AIR CONDITIONER-PASSENGER COMPARTMENT |

YEAR	TITLE	ILLUS. NO.	SECTION	PAGE
<b>JACK</b>				
1961/64	Spare Wheel & Jack Stowage (Ford)	P-3706	10	34
1962/	Spare Wheel & Jack Stowage (Fairlane-Body Type 54,62,65)	P-3706	10	34
1963/	Spare Wheel & Jack Stowage (Fairlane-Body Type 71)	P-4824	10	35
1960/	Spare Wheel & Jack Stowage (Falcon)	P-3916	10	38
1961/63	Spare Wheel & Jack Stowage (Thunderbird)	P-4598	10	37
1964/	Spare Wheel & Jack Stowage (Thunderbird)	P-4597	10	37
<b>SPEEDOMETER</b>				
	Speedometer - see Miscellaneous Illustrations in front of book			
	Speedometer Cable - see Section 172 - Group 17260 in Form AF 7681 (car text)			
<b>WINDSHIELD WASHER</b>				
1960	Windshield Washer (Ford-6 cylinder-without Air Conditioning)	P-3142	175	508
1960	Windshield Washer (Ford 8 cylinder-with Generator)	P-3143	175	509
1960	Windshield Washer (Ford-6 cylinder w/Air Conditioner)(8 cylinder w/Alternator System)	P-3067	175	507
1961/64	Windshield Washer (Ford)	P-3261	175	516
1962/	Windshield Washer (Fairlane)	P-3661	175	521
1960/62	Windshield Washer (Falcon)	P-3086	175	514
1963/	Windshield Washer (Falcon)	P-4726	175	525
1960	Windshield Washer (Thunderbird)	P-3204	175	512
1961/63	Windshield Washer (Thunderbird)	P-3281	175	519
1964/	Windshield Washer (Thunderbird)	P-4733	175	523
<b>WINDSHIELD WIPER</b>				
1960	Windshield Wiper (Ford)	P-3109	175	506
1962	Windshield Wiper (Ford)	P-3655	175	517
1963/64	Windshield Wiper (Ford)	P-4129	175	524
1962	Windshield Wiper (Fairlane)	P-3656	175	520
1963/	Windshield Wiper (Fairlane)	P-4173	175	521
1960/62	Windshield Wiper (Falcon)	P-3085	175	513
1963/	Windshield Wiper (Falcon)	P-4130	175	525
1960	Windshield Wiper (Thunderbird)	P-2654	175	511
1961	Windshield Wiper and Related Parts (Ford)	P-3392	175	515
1961/62	Windshield Wiper and Related Parts (Thunderbird)	P-3297	175	518
1963/	Windshield Wiper and Related Parts-Hydraulic (Thunderbird)	P-4053	175	523
<b>WINDSHIELD WIPER ELECTRIC MOTOR</b>				
1960/61	Windshield Wiper Electric Motor and Related Parts (Ford & Falcon)	P-3256	175	510
1961	Windshield Wiper Electric Motor and Related Parts (Thunderbird)	P-3256	175	510
1962	Windshield Wiper Electric Motor-Single Speed Autolite Type	P-3923	175	522
1963/64	Windshield Wiper Electric Motor-Single Speed Ford Type	P-3945	175	522
1963/	Windshield Wiper Electric Motor-2 Speed Ford Type	P-4200	175	524

## INDEX

YEAR	TITLE	ILLUS. NO.	SECTION	PAGE
<b>FRONT BUMPER</b>				
1960	Front Bumper and Related Parts (Ford)	P-2971	176	526
1961/62	Front Bumper and Related Parts (Ford)	P-3225	176	532
1963	Front Bumper and Related Parts (Ford)	P-3911	176	535
1964	Front Bumper and Related Parts (Ford)	P-4225	176	536
1962/63	Front Bumper and Related Parts (Fairlane)-Typical	P-3710	176	533
1964	Front Bumper and Related Parts (Fairlane)	P-4211	176	534
1960/61	Front Bumper and Related Parts (Falcon)	P-3110	176	529
1962/63	Front Bumper and Related Parts (Falcon)	P-3644	176	529
1964/	Front Bumper and Related Parts (Falcon)	P-4257	176	538
1960	Front Bumper, Radiator Grille and Related Parts (Thunderbird)	P-2997	176	527
1961/63	Front Bumper, Radiator Grille and Related Parts (Thunderbird)	P-3249	176	531
1964/	Front Bumper, Radiator Grille and Related Parts (Thunderbird)	P-4212	176	537
<b>REAR BUMPER</b>				
1960	Rear Bumper and Related Parts (Ford) -except with Spare Wheel Carrier	P-2987	176	526
1960	Rear Bumper and Related Parts (Ford)-with Spare Wheel Carrier	P-3178	10	32
1961	Rear Bumper and Related Parts (Ford)-except with Spare Wheel Carrier	P-3226	176	532
1961	Rear Bumper and Related Parts (Ford)-with Spare Wheel Carrier	P-3671	10	33
1962	Rear Bumper and Related Parts (Ford)	P-3638	176	533
1963	Rear Bumper and Related Parts (Ford)	P-3910	176	535
1964	Rear Bumper and Related Parts (Ford)	P-4256	176	536
1962/64	Rear Bumper and Related Parts (Fairlane)	P-3646	176	534
1960/63	Rear Bumper and Related Parts (Falcon)	P-3111	176	530
1964/	Rear Bumper and Related Parts (Falcon)	P-4259	176	538
1960	Rear Bumper (Thunderbird) -except with Spare Wheel Carrier	P-2460	176	528
1960	Rear Bumper and Related Parts (Thunderbird)-with Spare Wheel Carrier	P-2900	10	36
1961/63	Rear Bumper and Related Parts (Thunderbird)	P-3263	176	531
1964/	Rear Bumper and Related Parts (Thunderbird)	P-4226	176	537
<b>OUTSIDE REAR VIEW MIRROR</b>				
1963/	Remote Control Rear View Mirror-Door Mounted (Ford)	P-4542	176	539
1964/	Remote Control Rear View Mirror (Falcon and Fairlane)	P-4543	176	541
1963	Remote Control Rear View Mirror -Fender Mounted (Ford, Fairlane, Falcon)	P-4054	176	539
1963	Remote Control Rear View Mirror (Thunderbird)	P-4098	176	540
1964/	Remote Control Rear View Mirror (Thunderbird)	P-4541	176	540
	For Inside Rear View Mirror Refer to Body Illustration Section 030			
<b>SHOCK ABSORBERS</b>				
1960/64	Shock Absorber-Front (Ford)	P-2977	180	542
1960/64	Shock Absorber-Rear (Ford)	P-2984	180	542
1962	Shock Absorber-Front (Fairlane)	P-3675	30	69
1962/	Shock Absorber-Rear (Fairlane)	P-3662	53	136
1960/	Shock Absorber-Front (Falcon)	P-3129	180	544
1960/	Shock Absorber-Rear (Falcon)	P-3137	180	544
1960	Shock Absorber-Front (Thunderbird)	P-3091	180	543
1960	Shock Absorber-Rear (Thunderbird)	P-3065	180	543
1961/62	Shock Absorber-Front (Thunderbird)	P-3276	180	545
1961/63	Shock Absorber-Rear (Thunderbird) - Typical	P-3278	180	545
1963/	Shock Absorber-Front (Thunderbird)	P-4119	180	546
1964/	Shock Absorber-Rear (Thunderbird)	P-4352	180	546

**INDEX**

YEAR	TITLE	ILLUS. NO.	SECTION	PAGE
<b>HEATER</b>				
1960/61	Fresh Air Heater and Related Parts (Ford)- Typical	P-3087	184	547
1962/64	Fresh Air Heater and Related Parts (Ford)	P-4085	184	552
1962/	Fresh Air Heater and Related Parts (Fairlane)	P-3766	184	553
1960/	Fresh Air Heater and Related Parts (Falcon)	P-3145	184	549
1960	Fresh Air Heater and Related Parts (Thunderbird)	P-2861	184	548
1961/63	Fresh Air Heater and Related Parts (Thunderbird)	P-3272	184	551
1964/	Fresh Air Heater and Related Parts (Thunderbird)	P-4416	184	554
1961/63	Fresh Air Heater Engine Compartment Hoses and Connection (Thunderbird)	P-3803	184	550
<b>AIR CONDITIONER - ENGINE COMPARTMENT</b>				
1960/	Air Conditioner Compressor (Tecumseh Design)	P-4381	190	570
1960/	Air Conditioner Compressor (York Design)	P-4382	190	570
1962	Fairlane Hang-On Air Conditioner Condenser, Dehydrator & Compressor (6 cyl. 170)	P-3794	190	583
1962	Fairlane Hang-On Air Conditioner Condenser, Dehydrator & Compressor (8 cyl. 221)	P-3795	190	584
1960/62	Falcon Hang-On Air Conditioner Condenser, Compressor & Related Parts	P-3378	190	574
1963/	Air Conditioner Condenser, Dehydrator, Compressor & Related Parts-(Fairlane)-6 cylinder	P-4404	190	587
1963/	Hang-On Air Conditioner Condenser, Dehydrator, Compressor & Related Parts(Falcon-6 cyl.)	P-4402	190	576
1960/61	Integral Air Conditioner Condenser, Dehydrator, Compressor & Related Parts - (Ford-8 cylinder)	P-3151	190	577
1963	Integral Air Conditioner Condenser, Dehydrator, Compressor & Related Parts - (Ford-8 cylinder 352, 390 engines)	P-4172	190	586
1964	Air Conditioner Condenser, Dehydrator, Compressor & Related Parts - (Ford-8 cyl. 352, 390)	P-4408	190	588
1960/	Ford & Thunderbird Integral Air Conditioner Compressor Clutches & Related Parts	P-3216	190	571
1960	Ford & Thunderbird Integral Air Conditioner Compressor, Pulleys & Related Parts (Side Mounted Hoses)-1960 Thunderbird 1960/ Falcon-Typical	P-2724	190	572
1960/62	Ford & Thunderbird Integral Air Conditioner Compressor (Tecumseh Design)	P-3217	190	571
1960/62	Ford Hang-On Air Conditioner Condenser, Dehydrator, Compressor & Related Parts (6 cylinder 223 C. I. D. Engine)	P-3914	190	573
1963/64	Hang-On Air Conditioner Condenser, Dehydrator, Compressor & Related Parts - (Ford-6 cylinder)	P-4407	190	575
1962/62	Air Conditioner Condenser, Dehydrator, Compressor & Related Parts (Ford-8 cylinder)	P-3265	190	579
1962	Ford Integral Air Conditioner & Heater Vacuum Hose Installation	P-3817	190	580
1963/64	Integral Air Conditioner Condenser, Dehydrator, Compressor & Related Parts - (Ford, Fairlane-8 cylinder 260, 289 engines)	P-4163	190	585
1960	Thunderbird Integral Air Conditioner Condenser, Compressor & Related Parts	P-2932	190	578
1961	Thunderbird Integral Air Conditioner Condenser, Dehydrator, Compressor & Related Parts	P-3294	190	581
1964	Thunderbird Integral Air Conditioner Condenser, Dehydrator, Compressor & Related Parts	P-4409	190	589
1962/63	Thunderbird Integral Air Conditioner Condenser, Dehydrator, Compressor, Hoses & Related Parts	P-3804	190	582
<b>AIR CONDITIONER - PASSENGER COMPARTMENT</b>				
1962	Hang-On Air Conditioner Evaporator & Control (Ford, Fairlane & Falcon)	P-3918	190	564
1963/64	Hang-On Air Conditioner Evaporator, Controls & Related Parts (Ford, Fairlane, "Falcon-Before 3/2/64")	P-4156	190	566
1964/	Hang-On Air Conditioner Evaporator, Control & Related Parts ("Falcon-From 3/2/64")	P-4549	190	567
1960/62	Hang-On Air Conditioner Evaporator, Register & Related Parts (Ford-6 & 8 cylinder)	P-3148	190	555
1962	Hang-On Air Conditioner Evaporator, Register & Related Parts (Fairlane)	P-3746	190	565
1960/62	Hang-On Air Conditioner Register, Evaporator & Related Parts (Falcon)	P-3379	190	560
1960	Integral Air Conditioner Evaporator, Blower & Related Parts (Thunderbird)	P-2933	190	558
1961/63	Integral Air Conditioner Evaporator, Blower & Related Parts (Thunderbird)	P-3295	190	562
1964/	Integral Air Conditioner Evaporator, Blower, Register & Controls (Thunderbird)	P-4415	190	569
1963/	Integral Air Conditioner Evaporator, Control & Related Parts(Ford and Fairlane)	P-4157	190	568
1960	Integral Air Conditioner Evaporator, Heater & Related Parts (Ford)	P-3152	190	556
1961/62	Integral Air Conditioner Evaporator, Heater & Related Parts (Ford)	P-3266	190	561
1960/62	Integral Air Conditioner Instrument Panel Controls & Related Parts (Ford)	P-3150	190	557
1960	Integral Air Conditioner Instrument Panel Controls & Related Parts (Thunderbird)	P-2934	190	559
1961/63	Integral Air Conditioner Instrument Panel Controls & Related Parts (Thunderbird)	P-3293	190	563

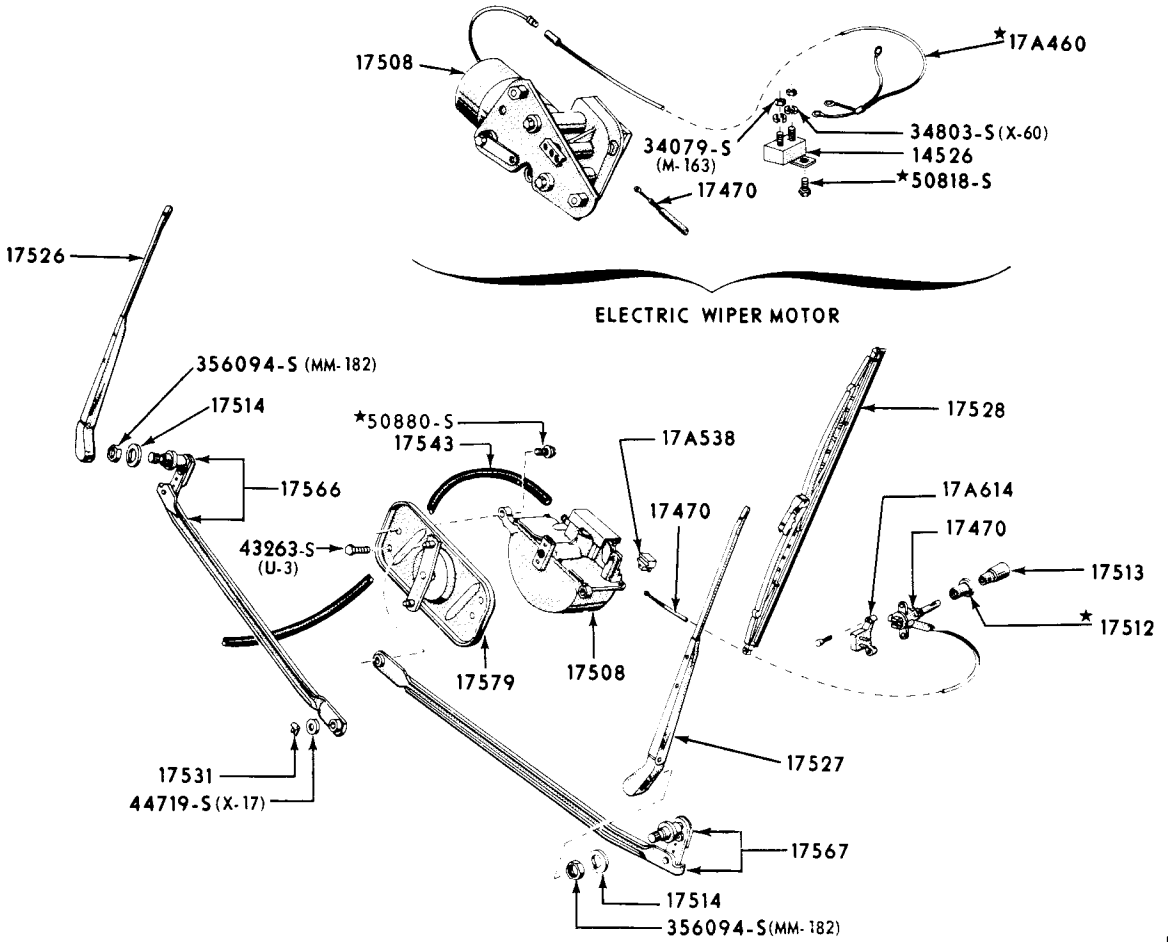

P-3109

1960 WINDSHIELD WIPER (FORD)

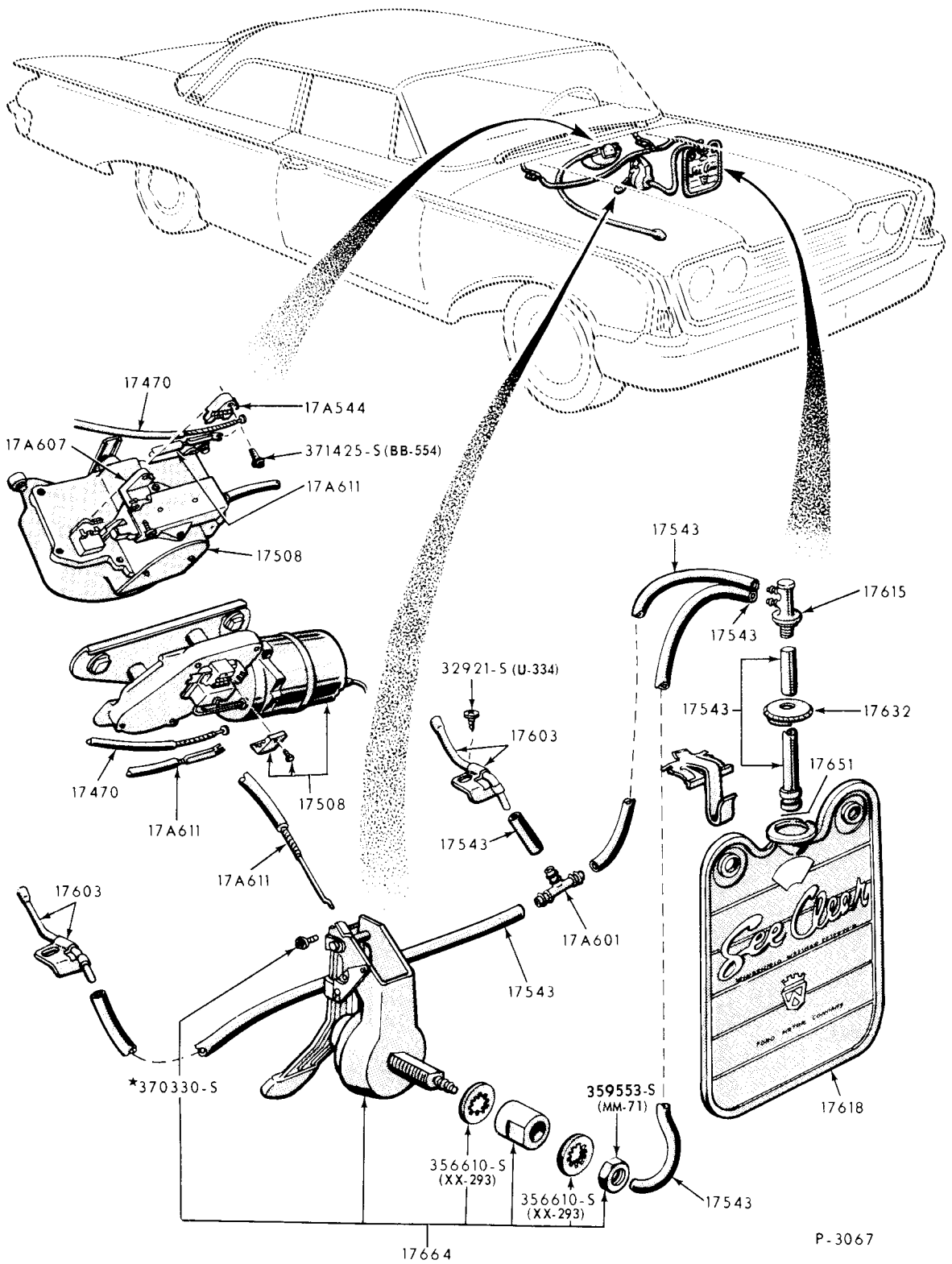

P-3067

1960 WINDSHIELD WASHER (FORD)  
(6 CYLINDER WITH AIR CONDITIONING)  
(8 CYLINDER WITH ALTERNATOR SYSTEM)

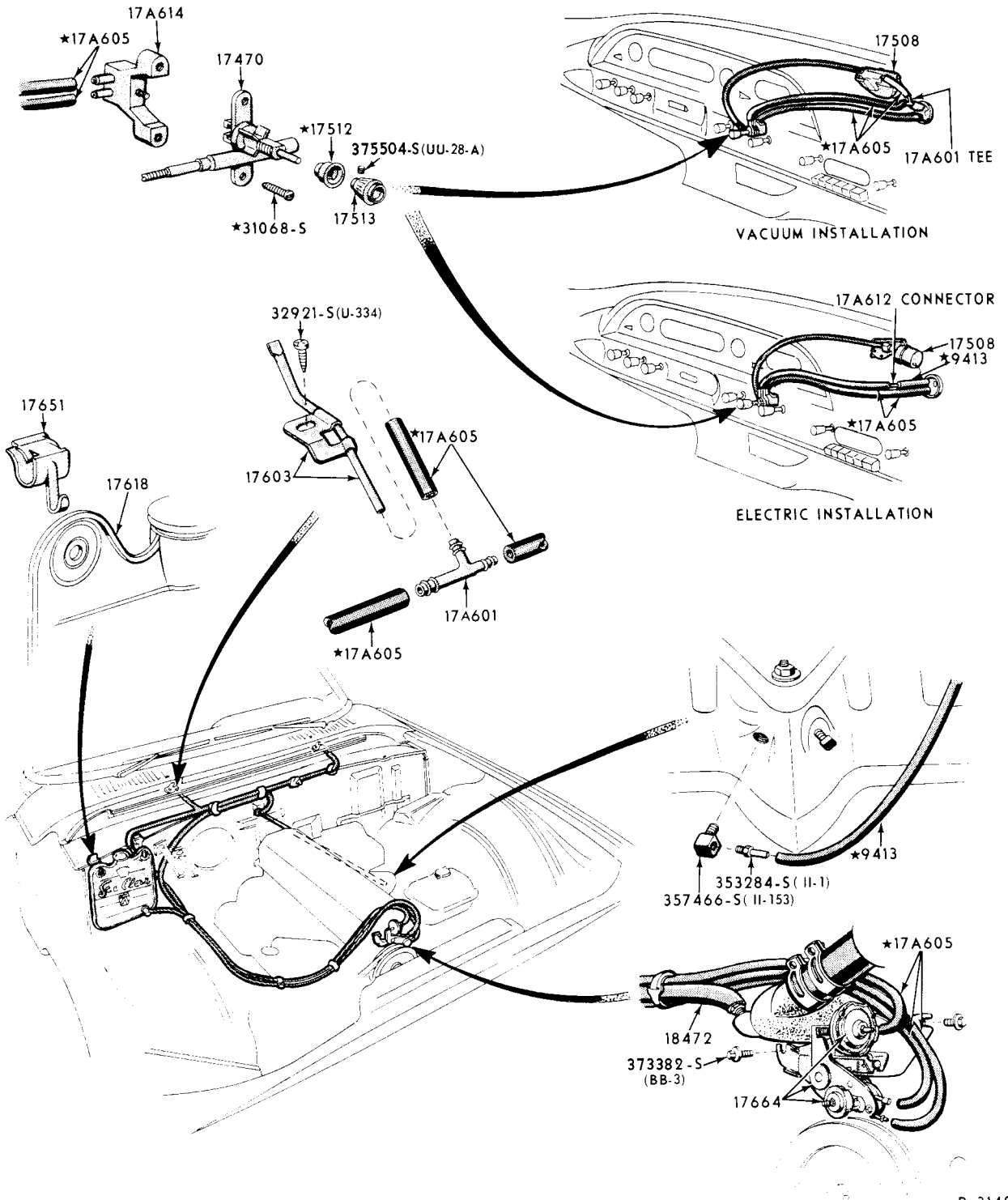

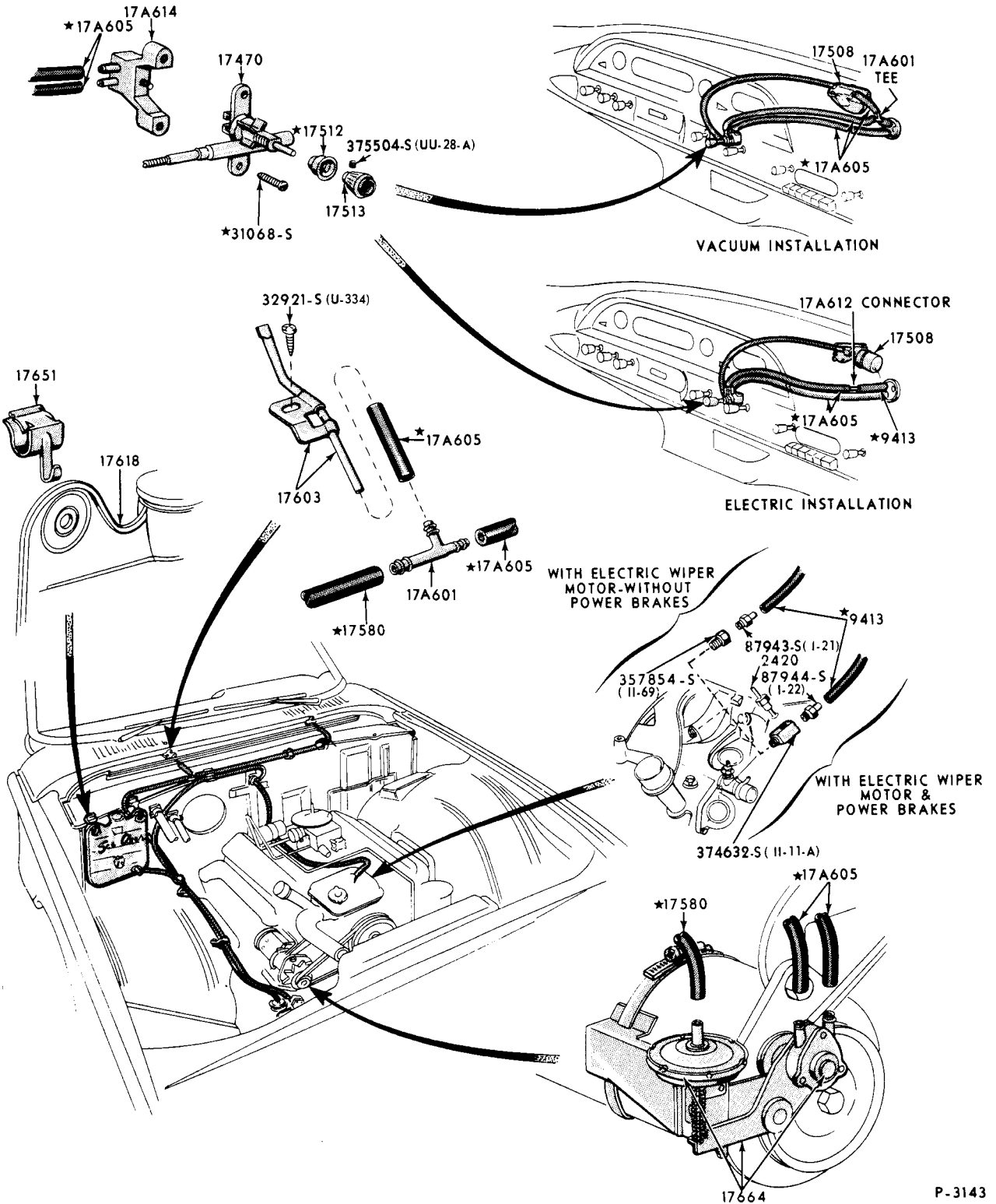

1960 WINDSHIELD WASHER (FORD-8 CYLINDER-WITH GENERATOR)

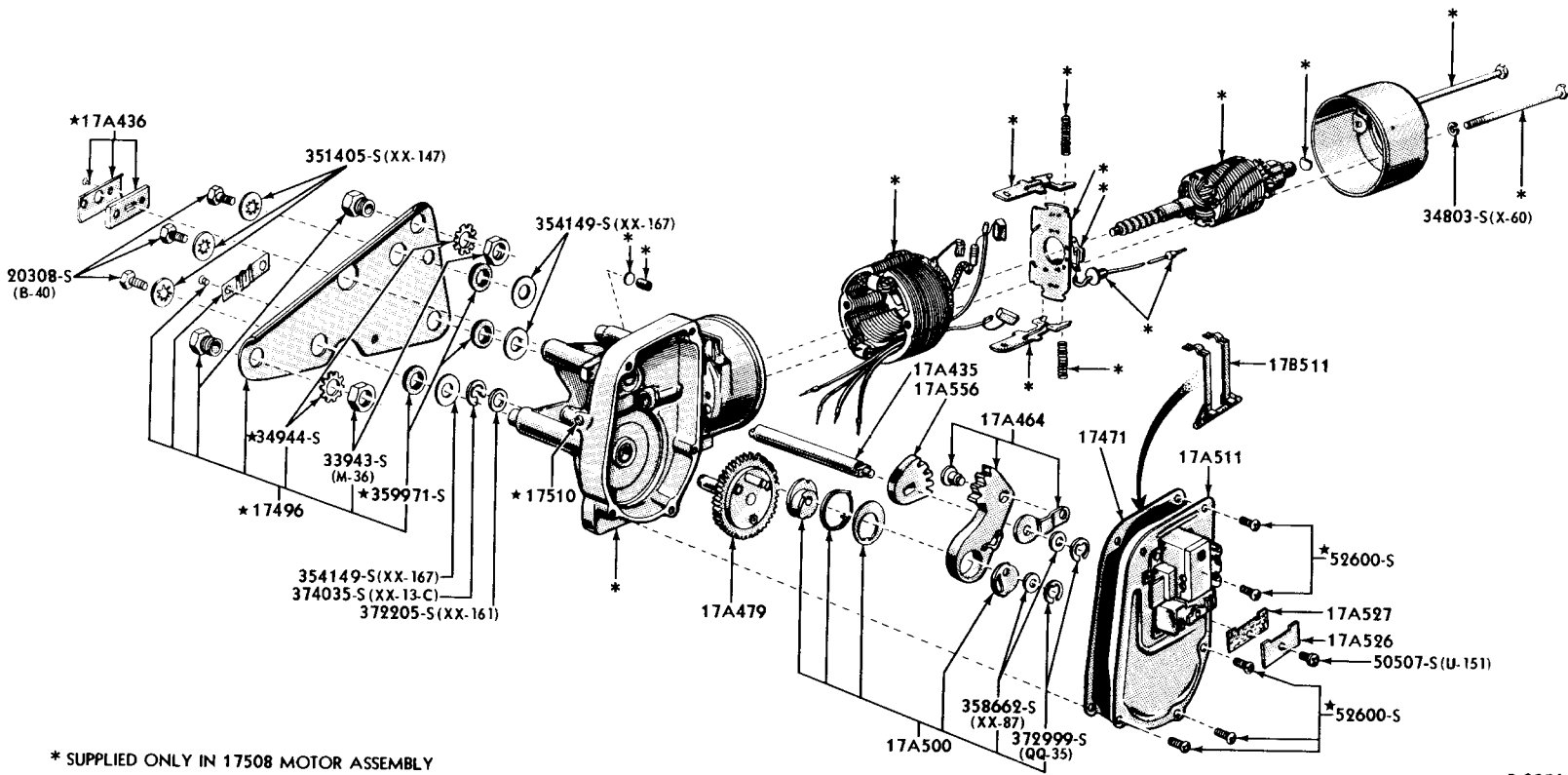

\* SUPPLIED ONLY IN 17508 MOTOR ASSEMBLY

ELECTRIC WINDSHIELD WIPER MOTOR & RELATED PARTS  
1960/61 FORD & FALCON 1961 THUNDERBIRD



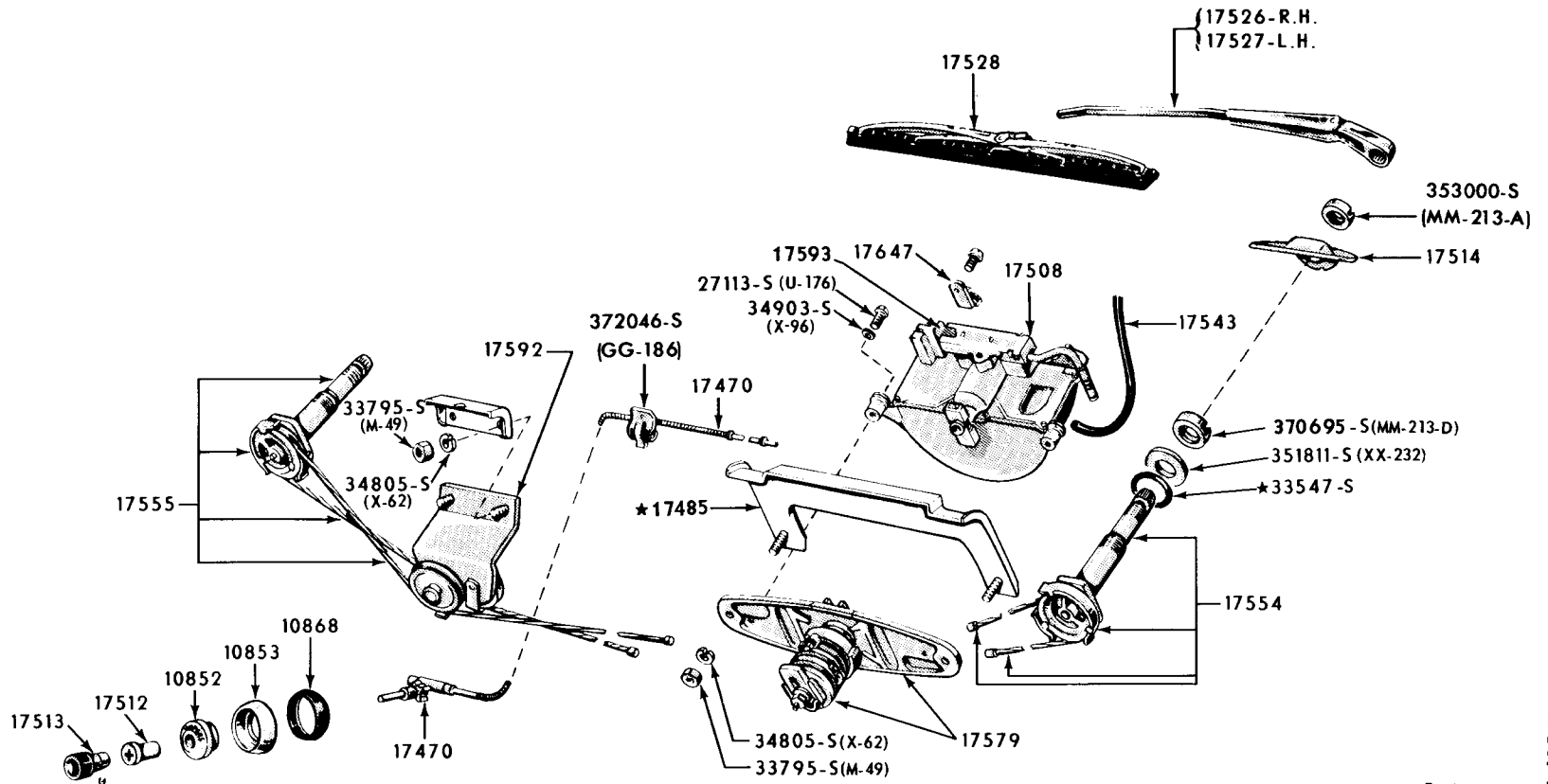

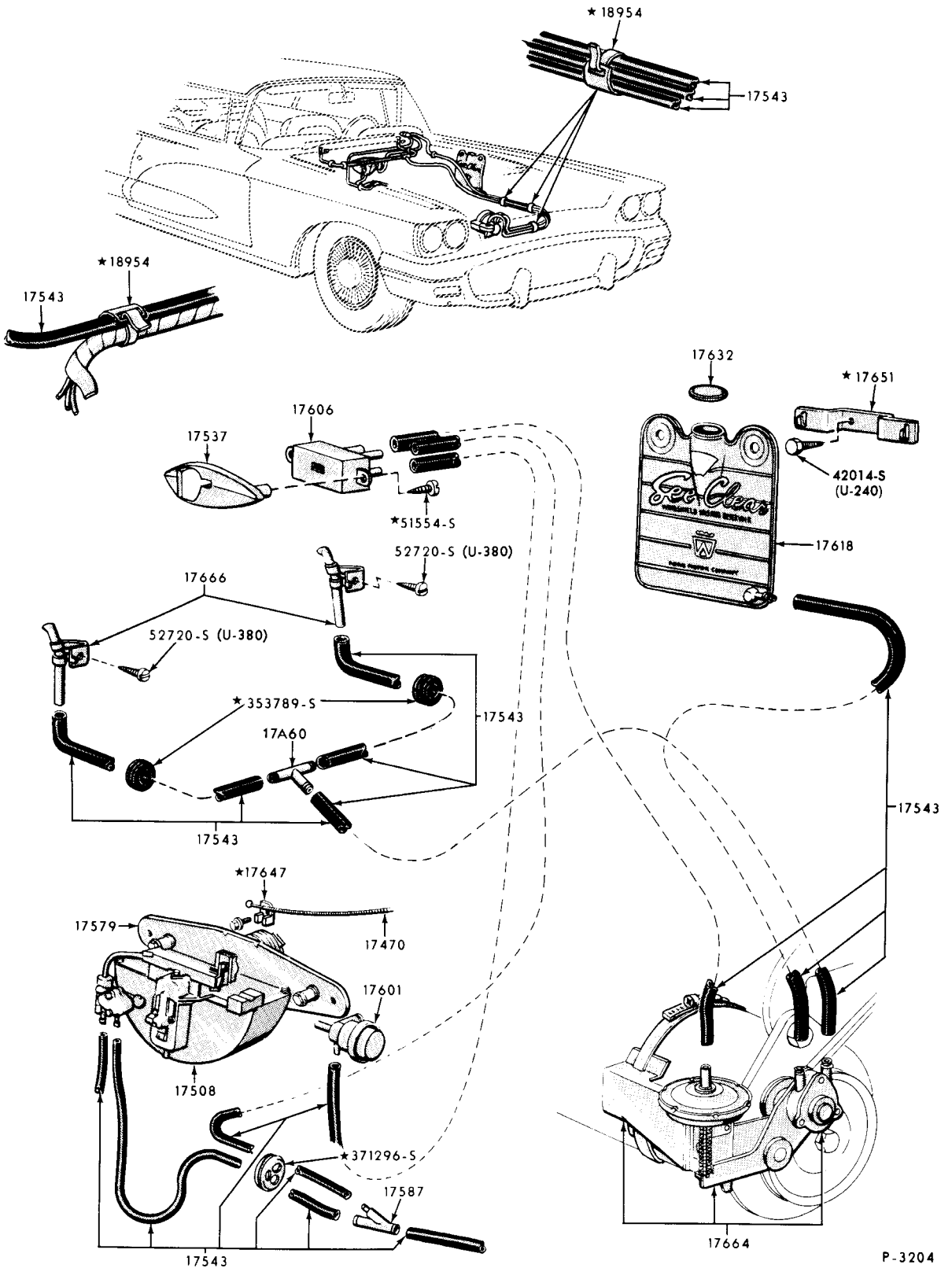



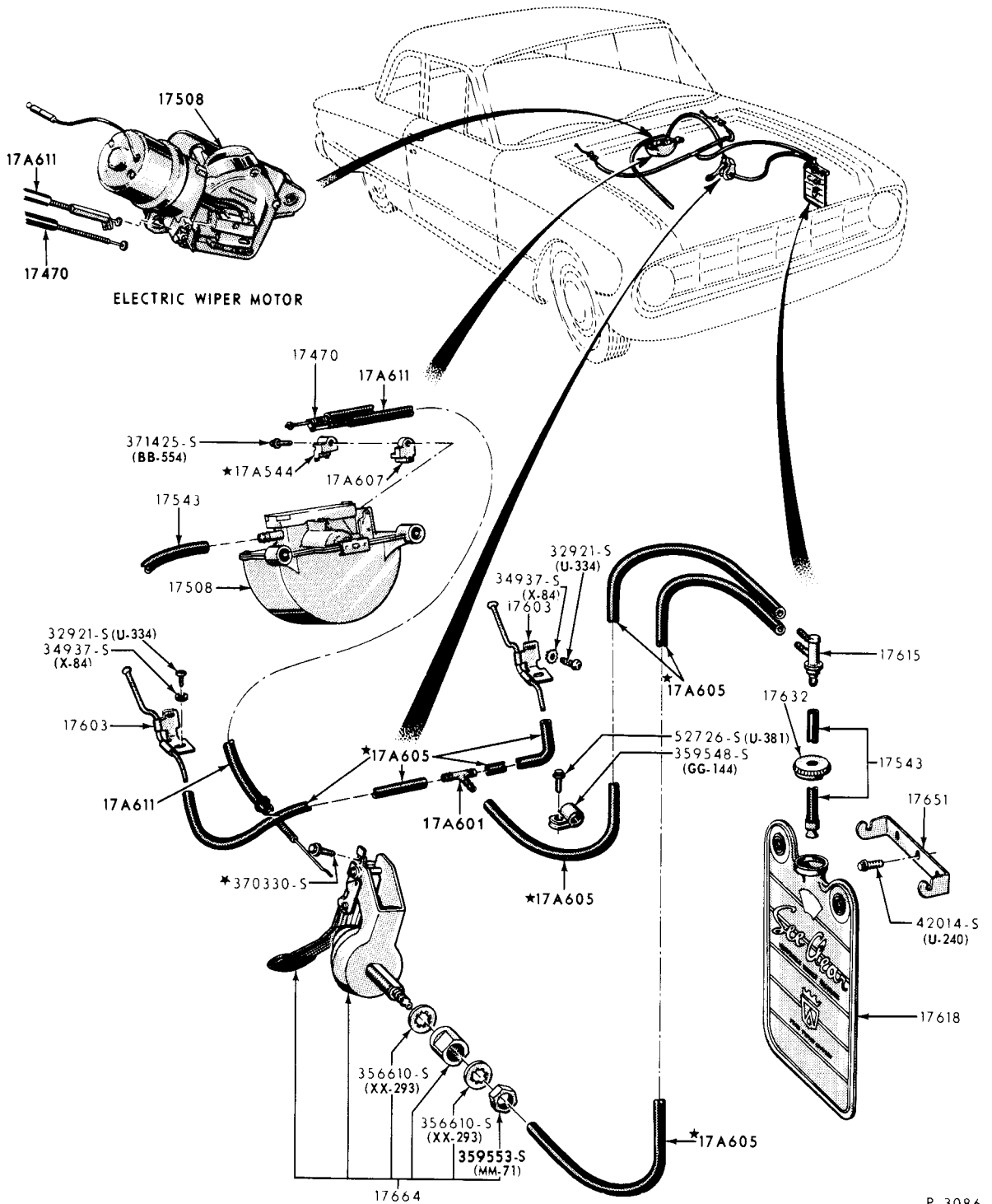

P-3086

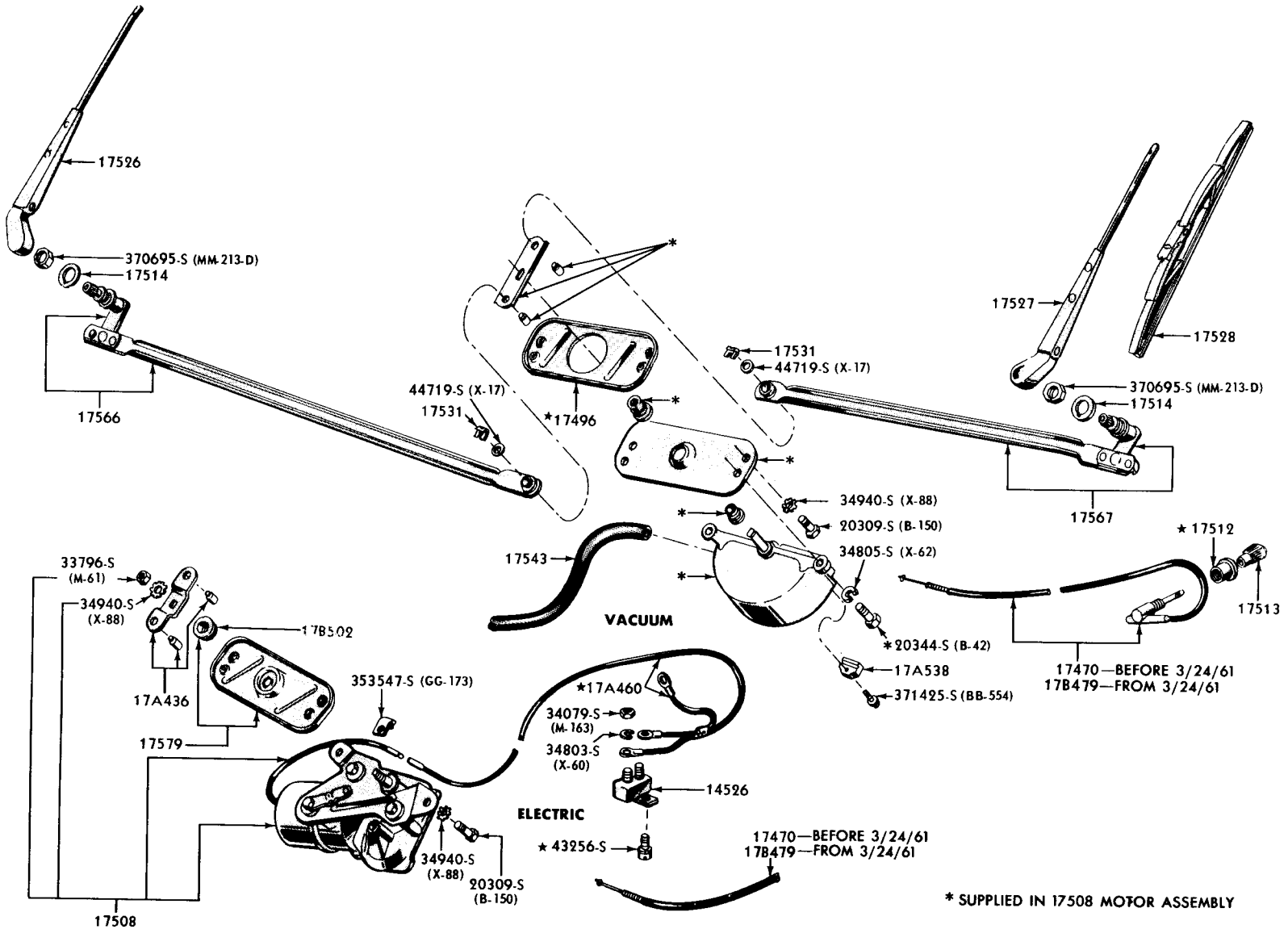

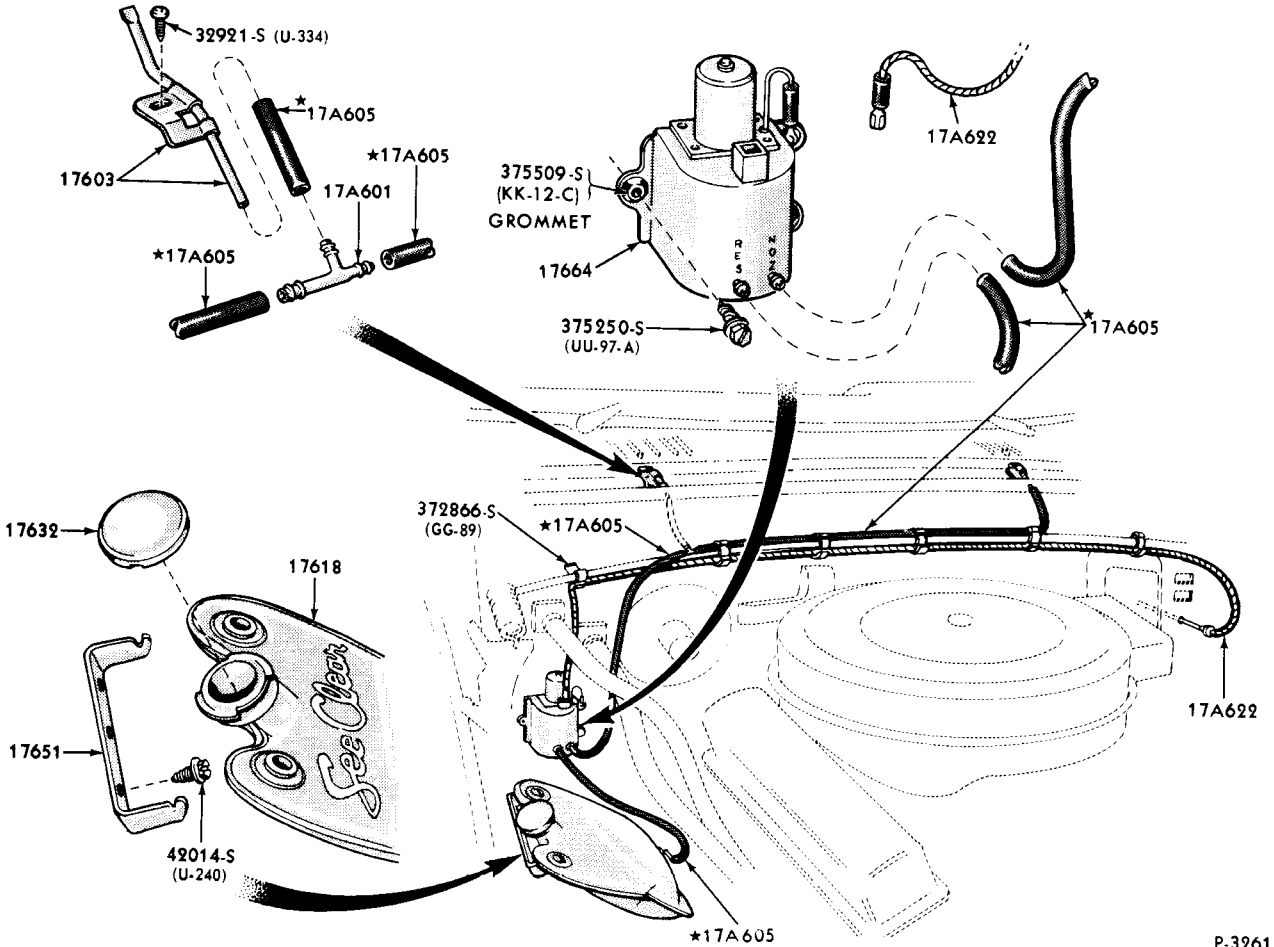
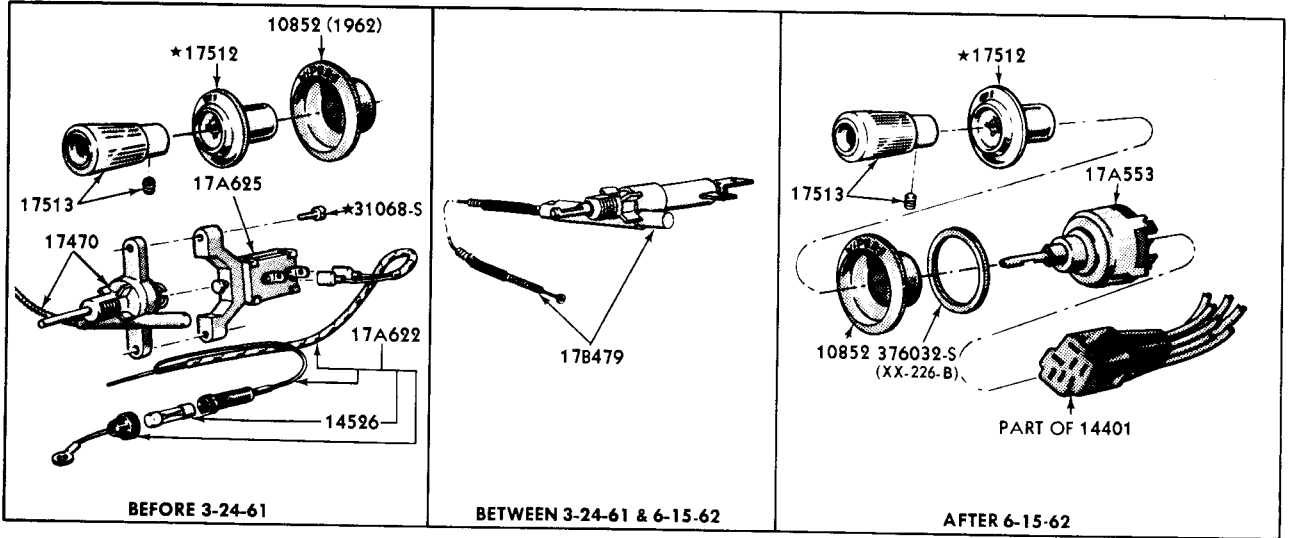

P-3261

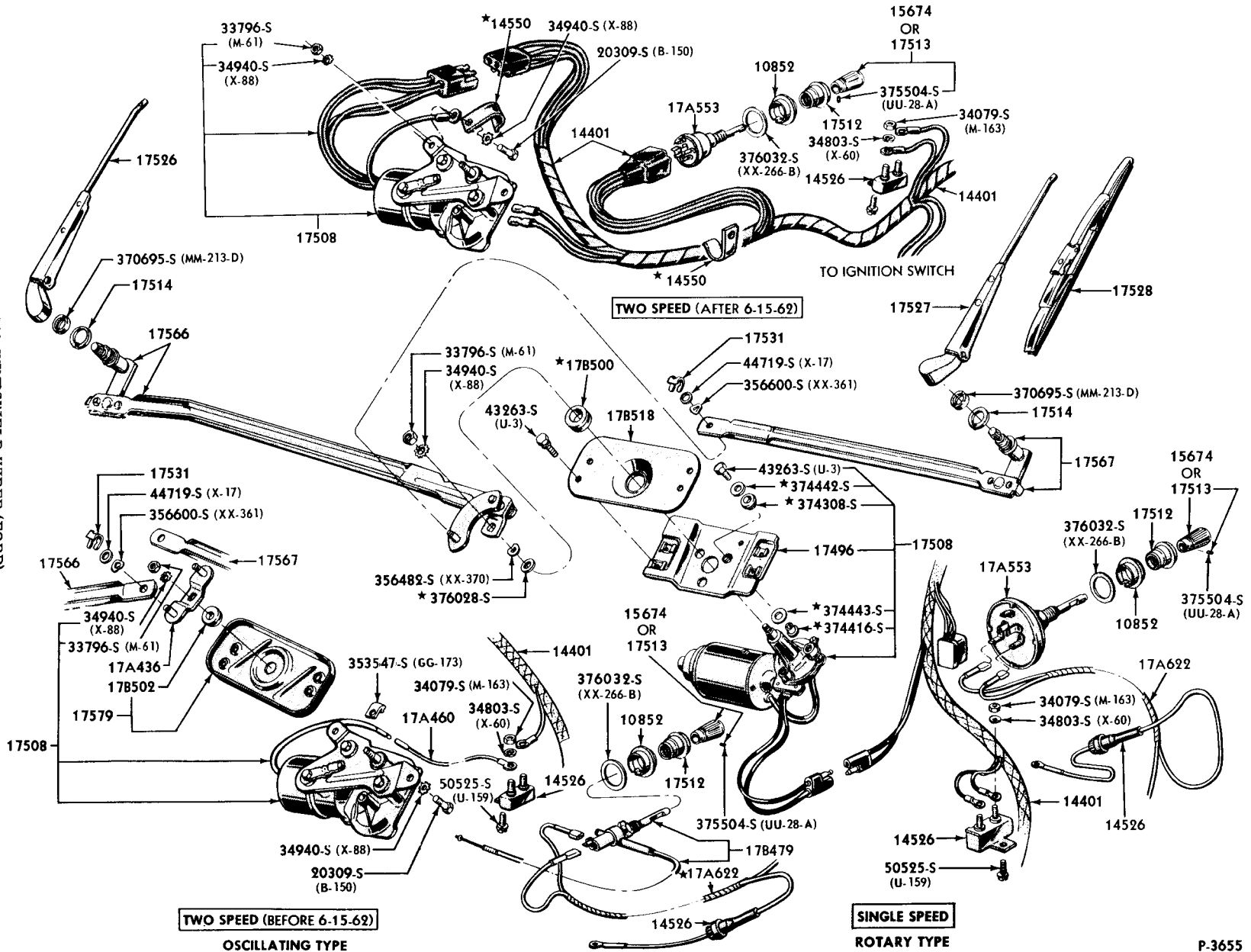

TWO SPEED (BEFORE 6-15-62)  
OSCILLATING TYPE

TWO SPEED (AFTER 6-15-62)

SINGLE SPEED  
ROTARY TYPE

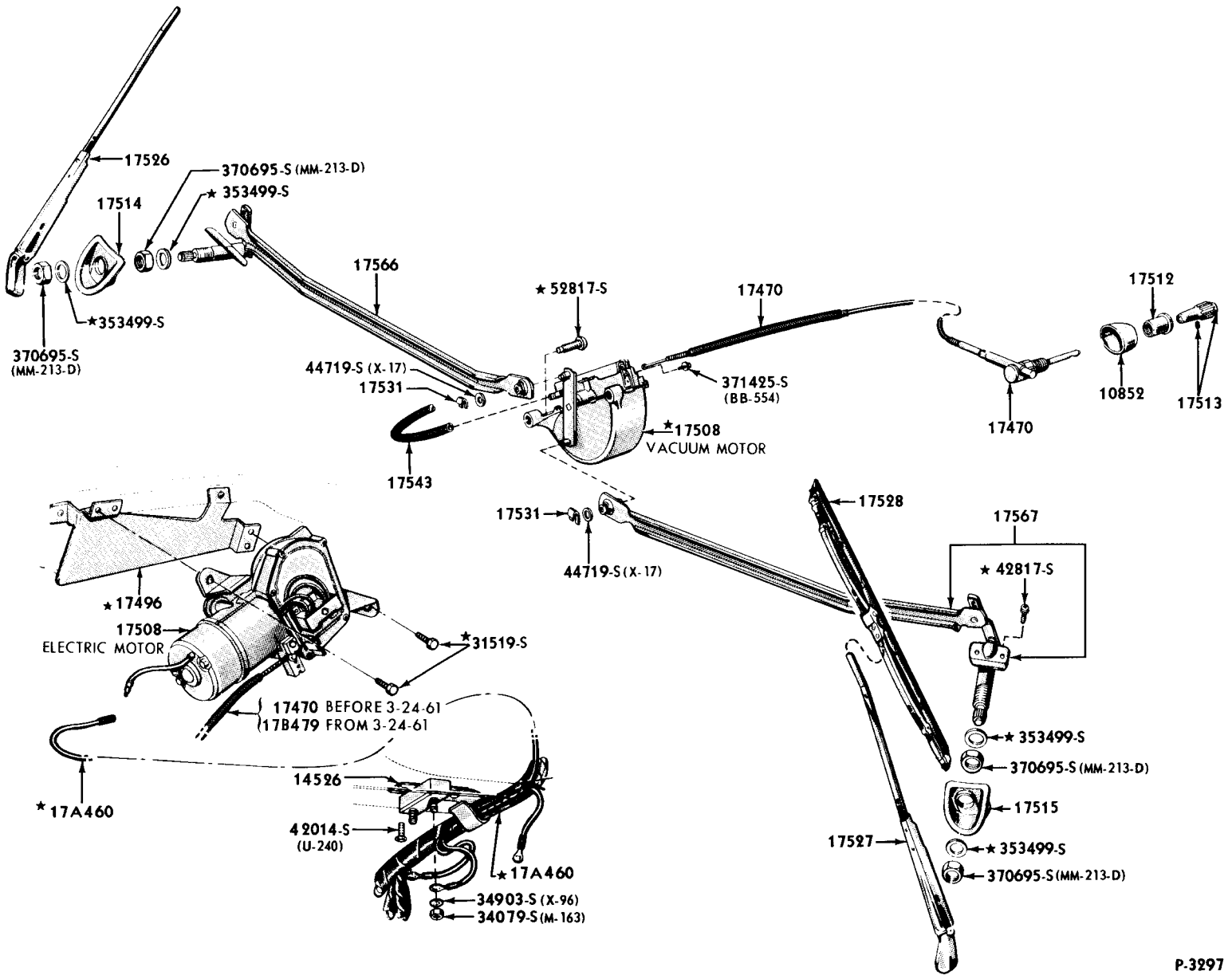

1951/62 WINDSHIELD WIPER & RELATED PARTS (THUNDERBIRD)



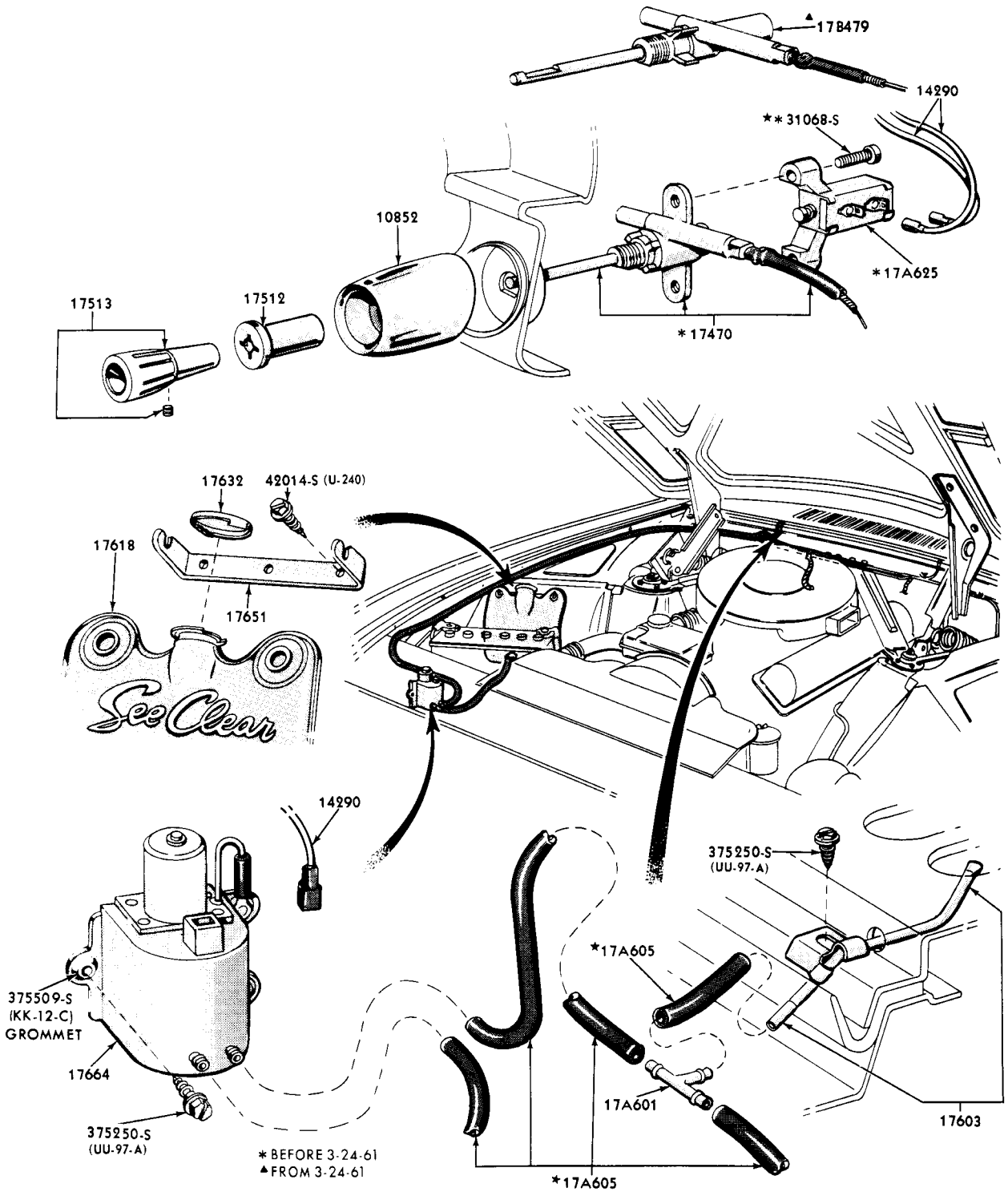

P-3281

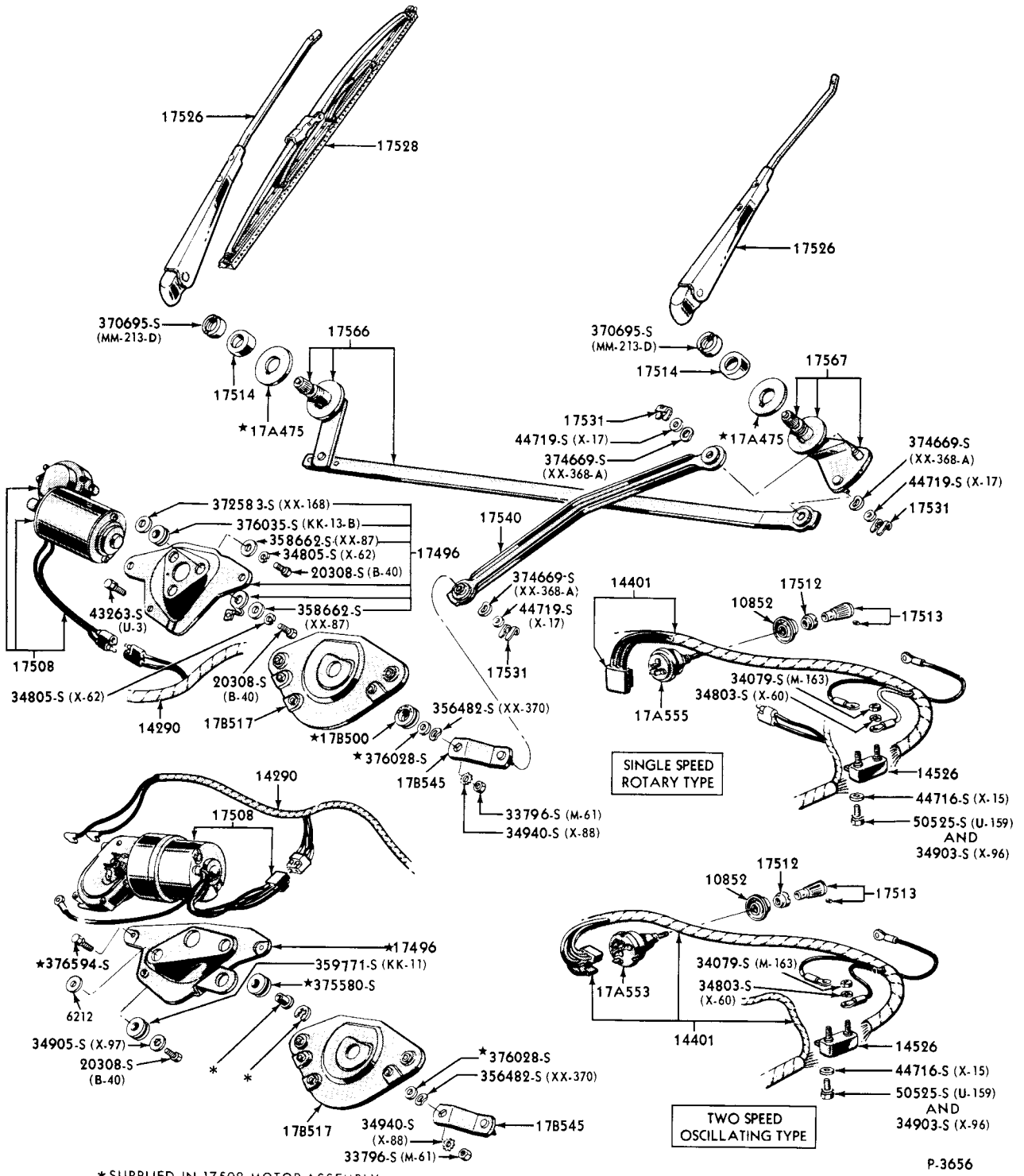

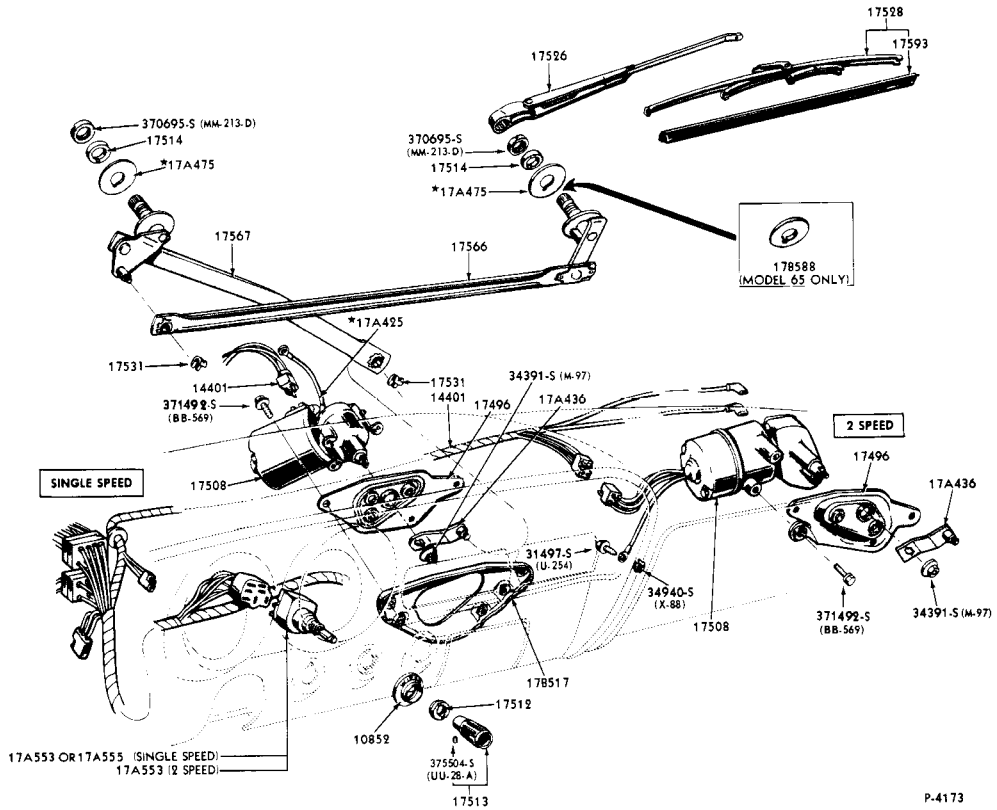

P-4173

1933/ WINDSHIELD WIPER (FAIRLANE)

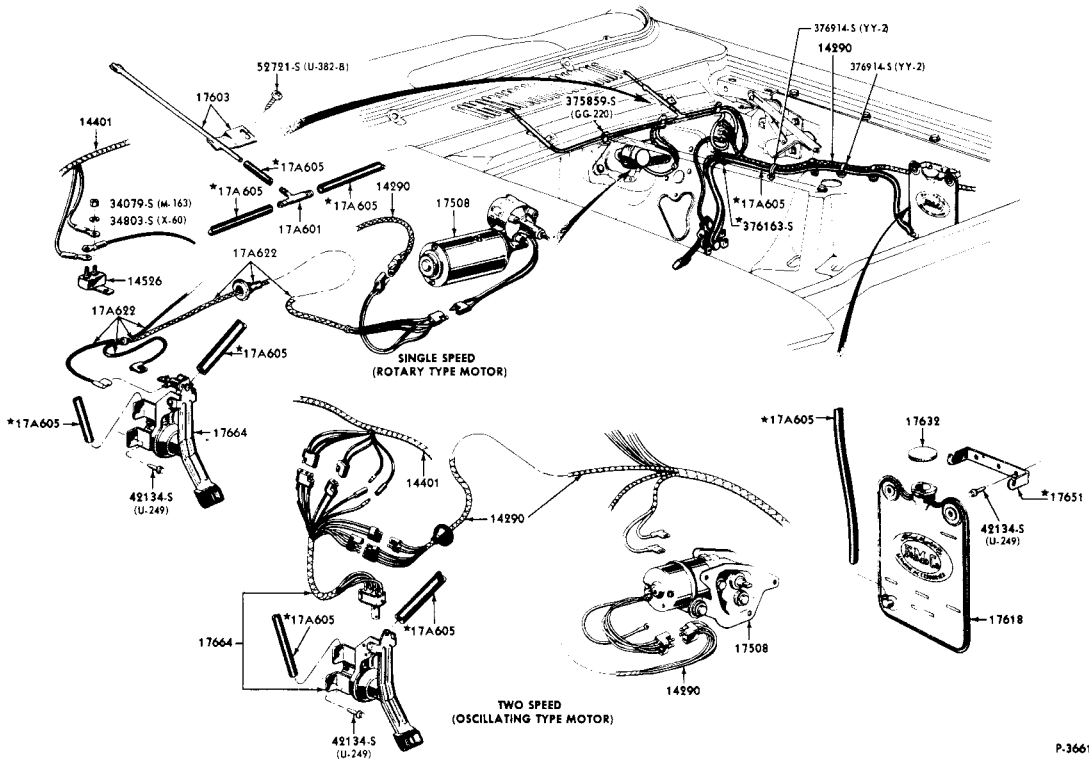

P-3661

1962/ WINDSHIELD WASHER (FAIRLANE)

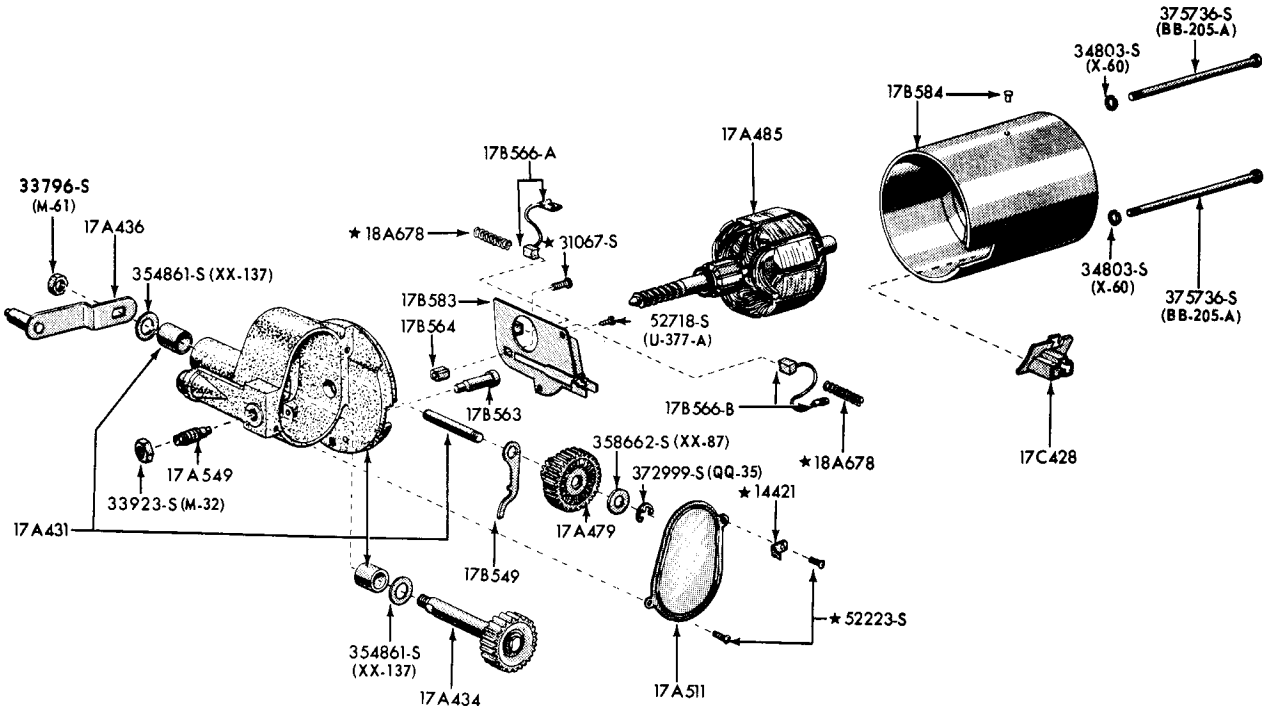

P-3945

1963/64 WINDSHIELD WIPER ELECTRIC MOTOR -SINGLE SPEED FORD TYPE

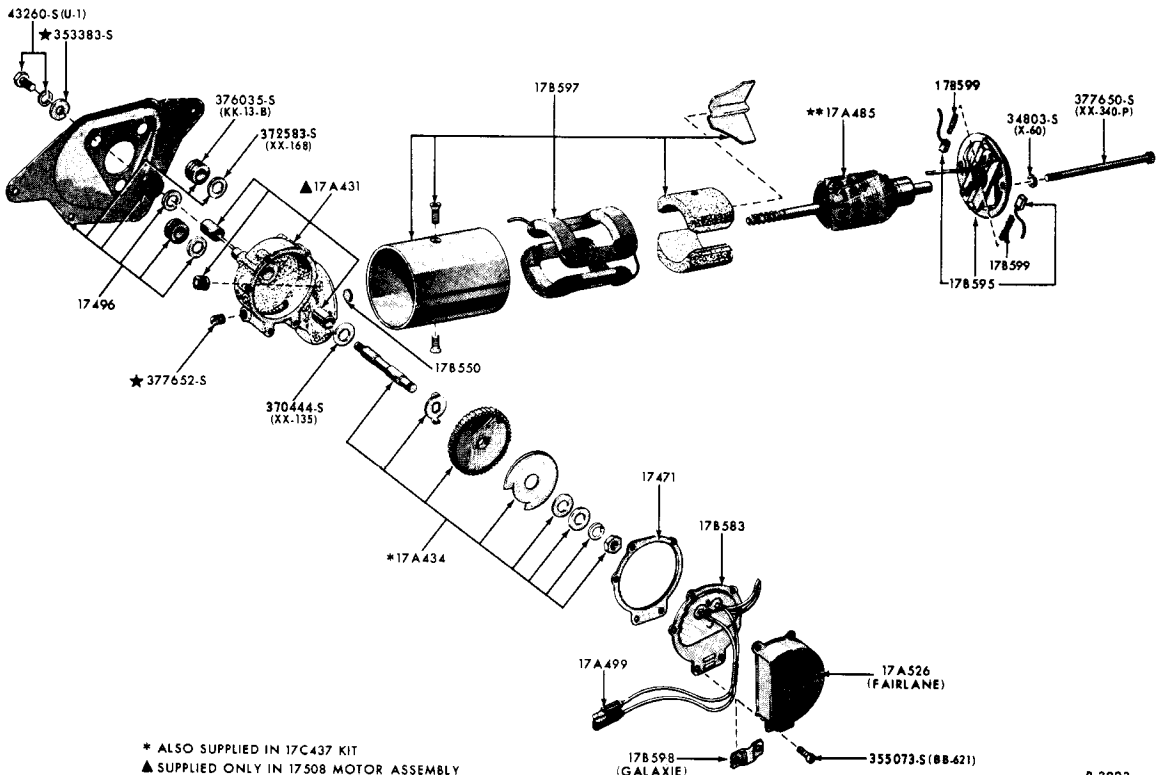

\* ALSO SUPPLIED IN 17C437 KIT  
 ▲ SUPPLIED ONLY IN 17508 MOTOR ASSEMBLY

P-3923

1962 WINDSHIELD WIPER ELECTRIC MOTOR-SINGLE SPEED AUTOLITE TYPE

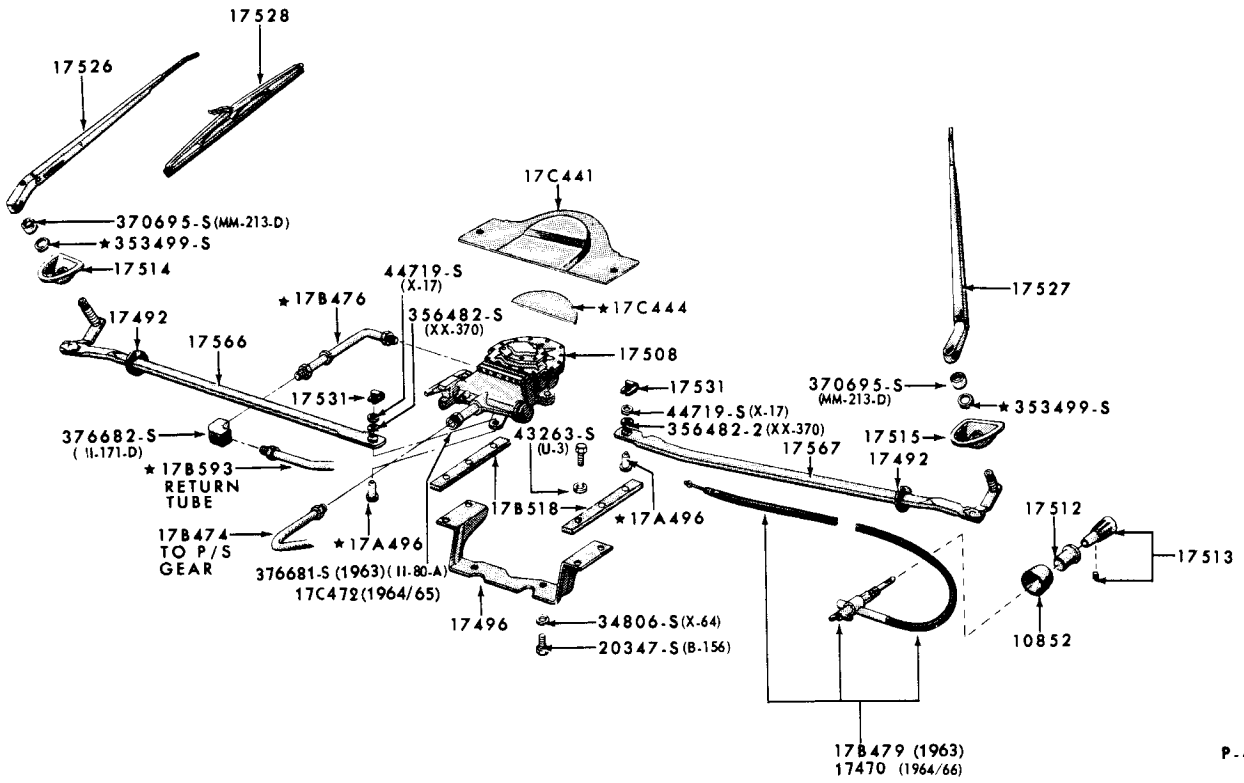

P-4053

1963/ WINDSHIELD WIPER AND RELATED PARTS - HYDRAULIC (THUNDERBIRD)

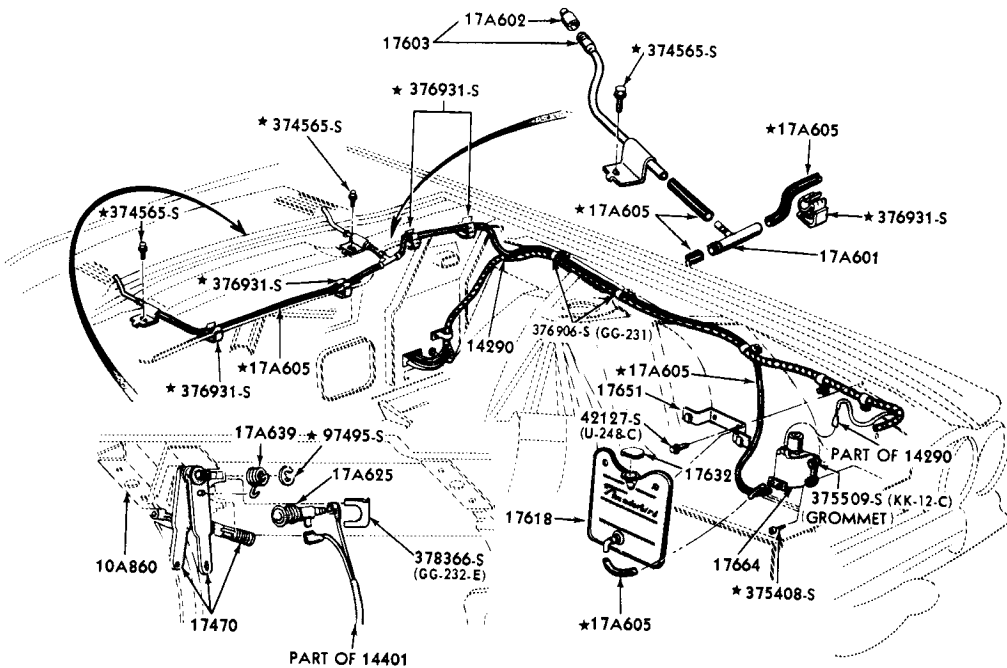

P-4733

1964/ WINDSHIELD WASHER (THUNDERBIRD)

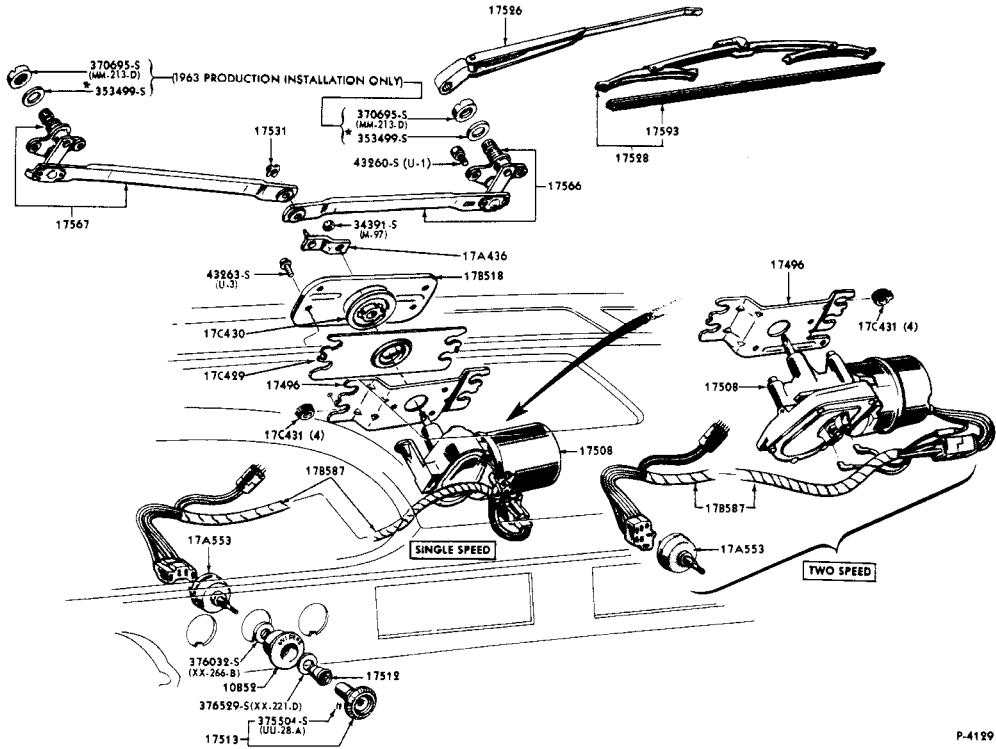

P-4199

1963/64 WINDSHIELD WIPER (FORD)

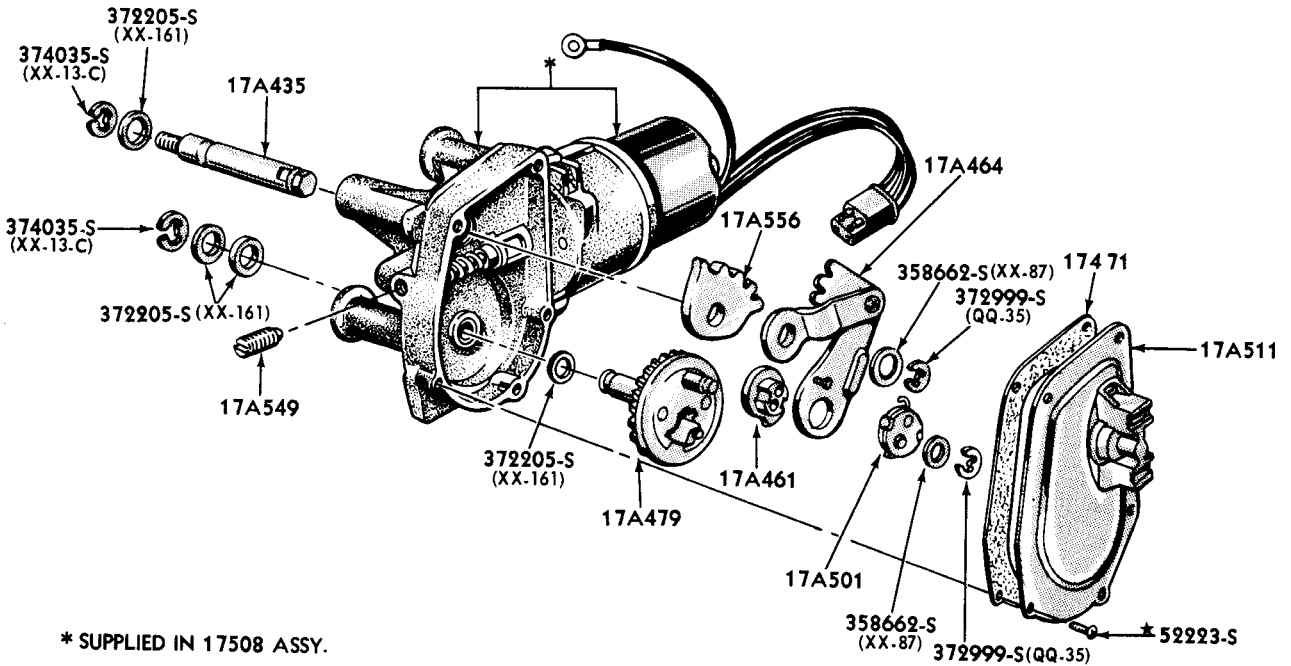

P-4200



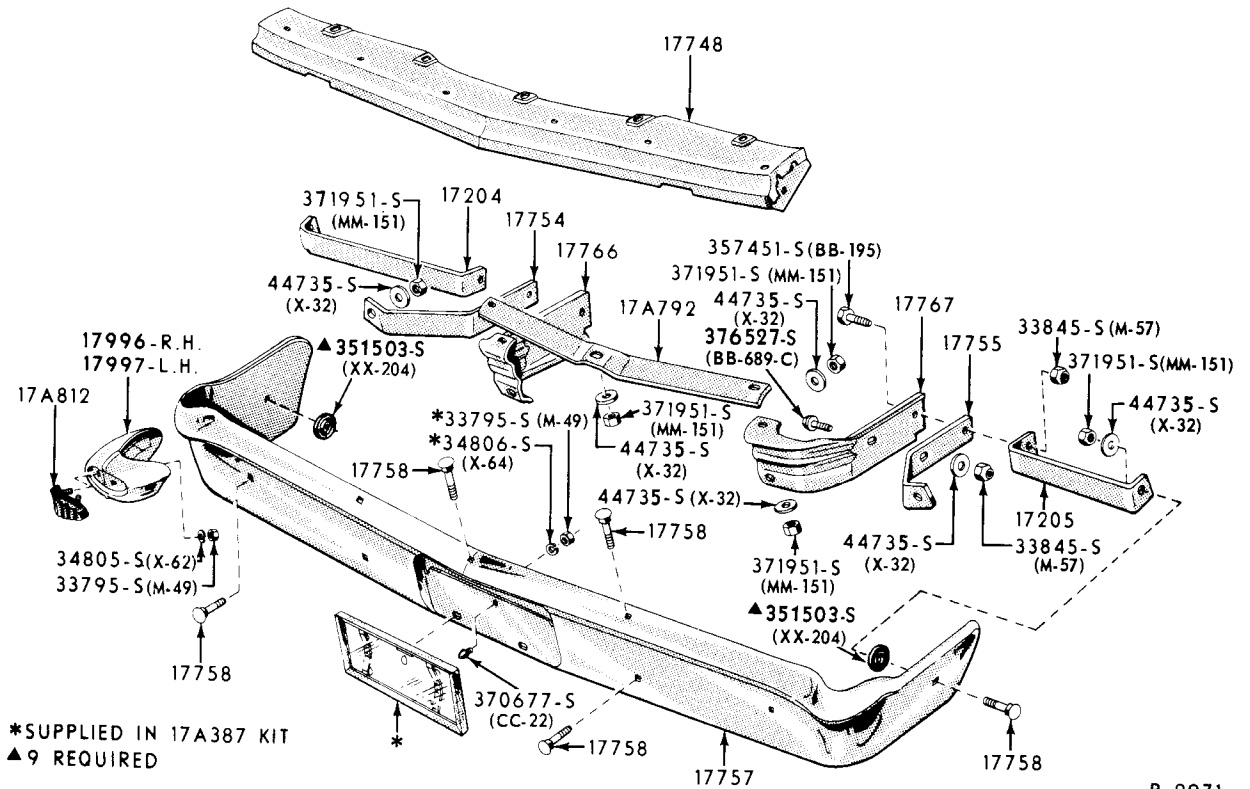

1960 FRONT BUMPER & RELATED PARTS (FORD)

P-2971

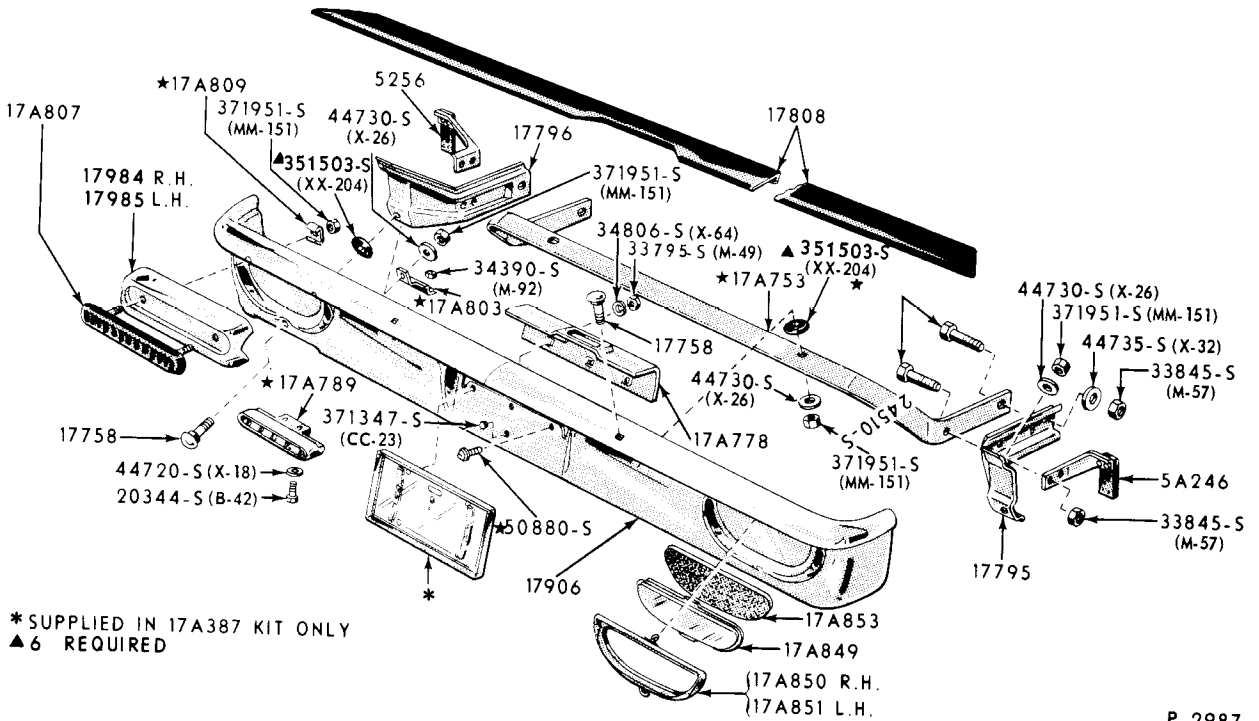

1960 REAR BUMPER & RELATED PARTS (FORD)-EXCEPT WITH SPARE WHEEL CARRIER FOR SPARE WHEEL CARRIER ILLUSTRATION, SEE ILLUSTRATION SECTION 10

P-2987







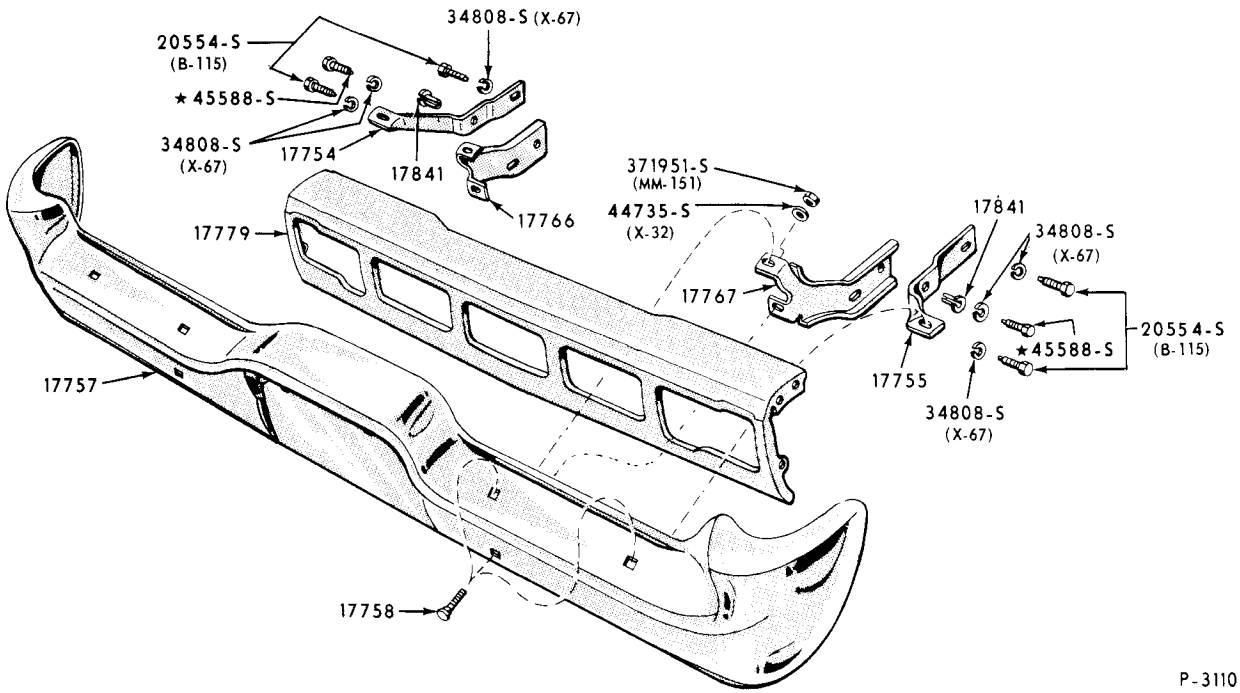

P-3110

1960/61 FRONT BUMPER & RELATED PARTS (FALCON)

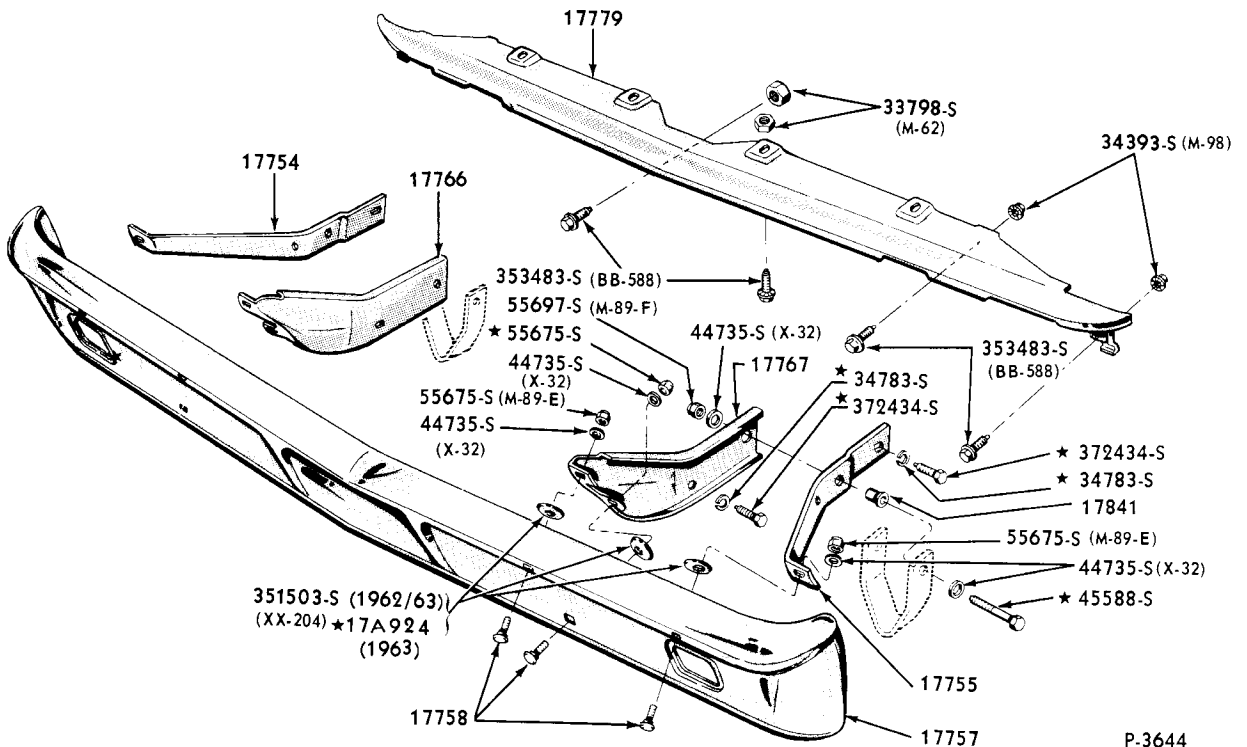

P-3644

1962/63 FRONT BUMPER & RELATED PARTS (FALCON)

BODY TYPE 59, 66, 71, 78

BODY TYPE 58, 64

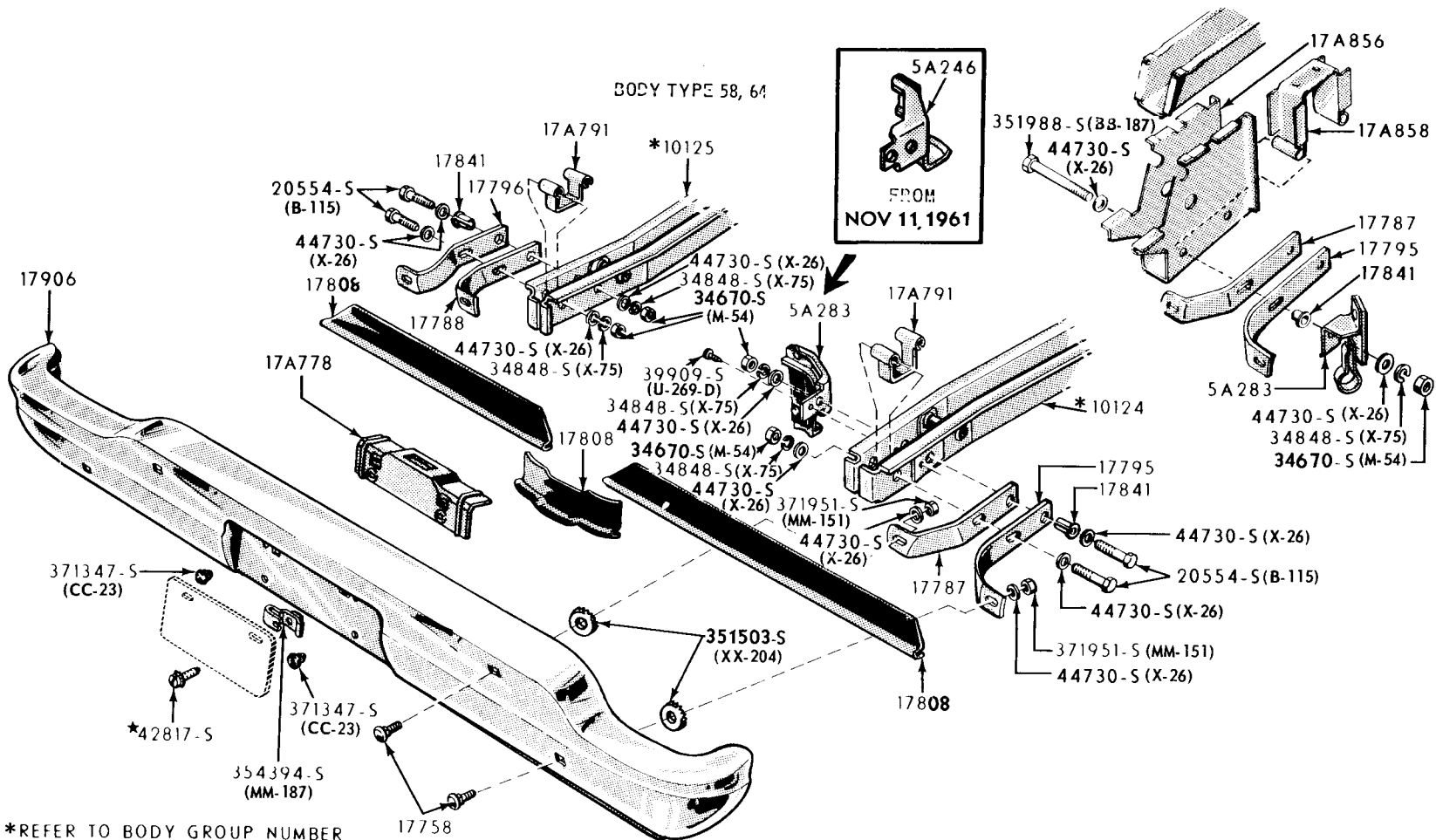
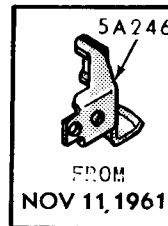

1960/63 REAR BUMPER and RELATED PARTS (FALCON)

\*REFER TO BODY GROUP NUMBER

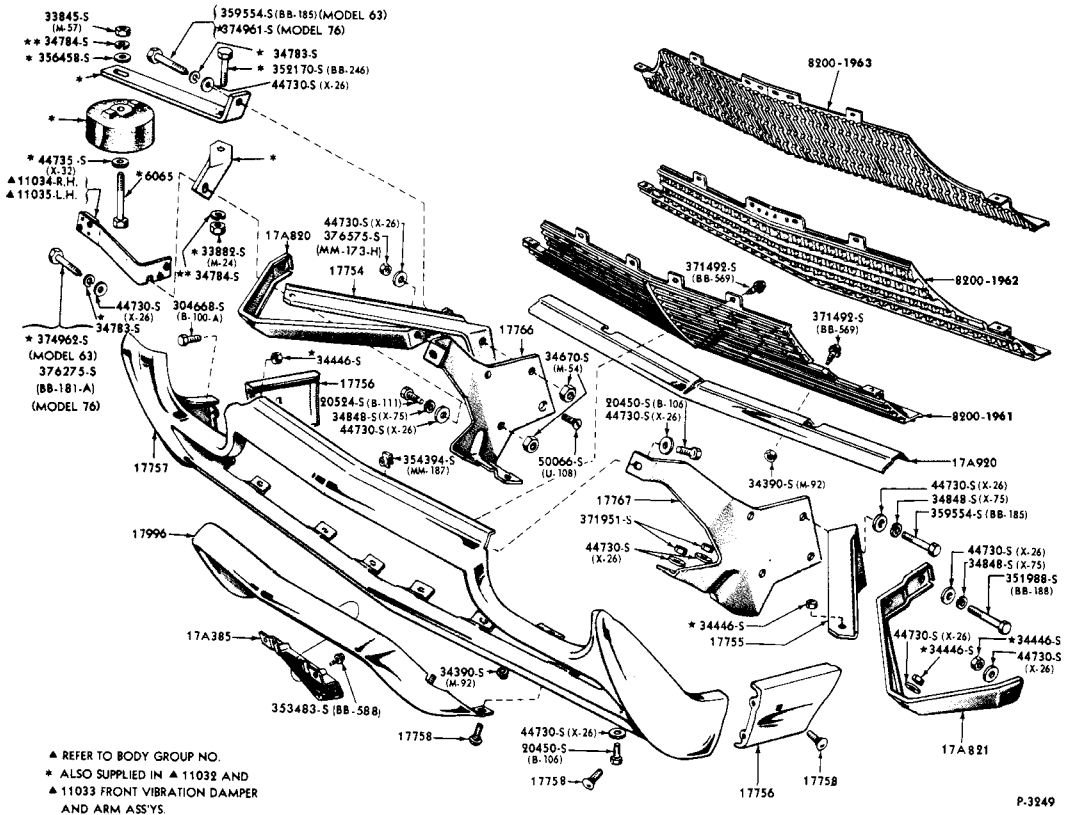

1961/63 FRONT BUMPER, RADIATOR GRILLE and RELATED PARTS (THUNDERBIRD)

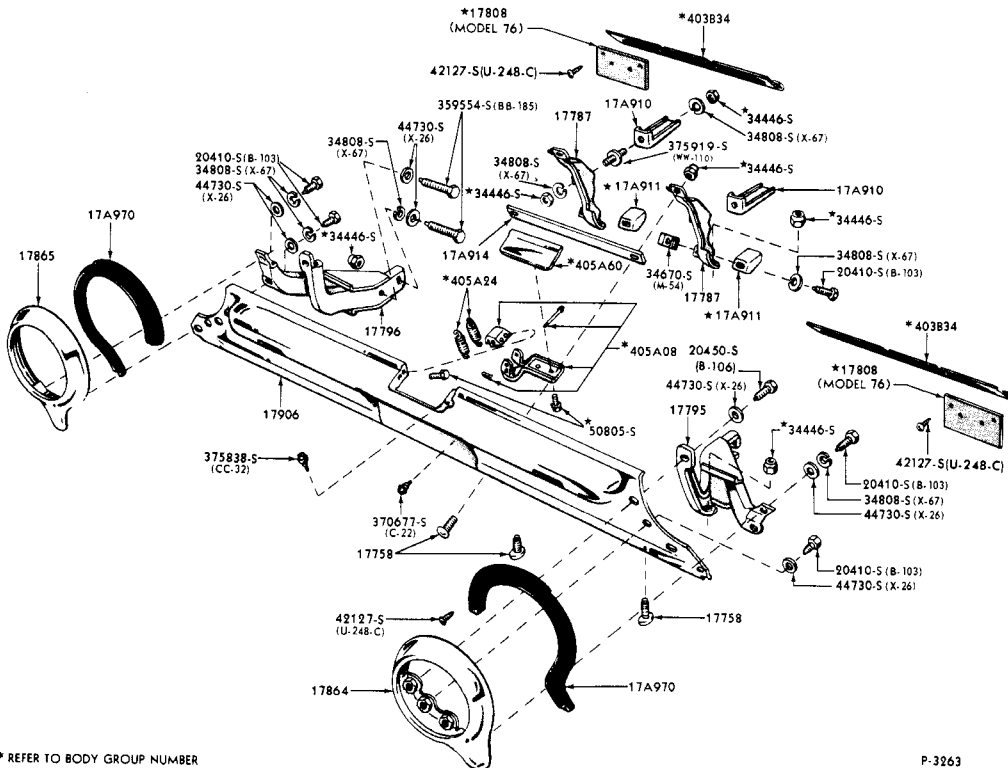

1961/63 REAR BUMPER and RELATED PARTS (THUNDERBIRD)

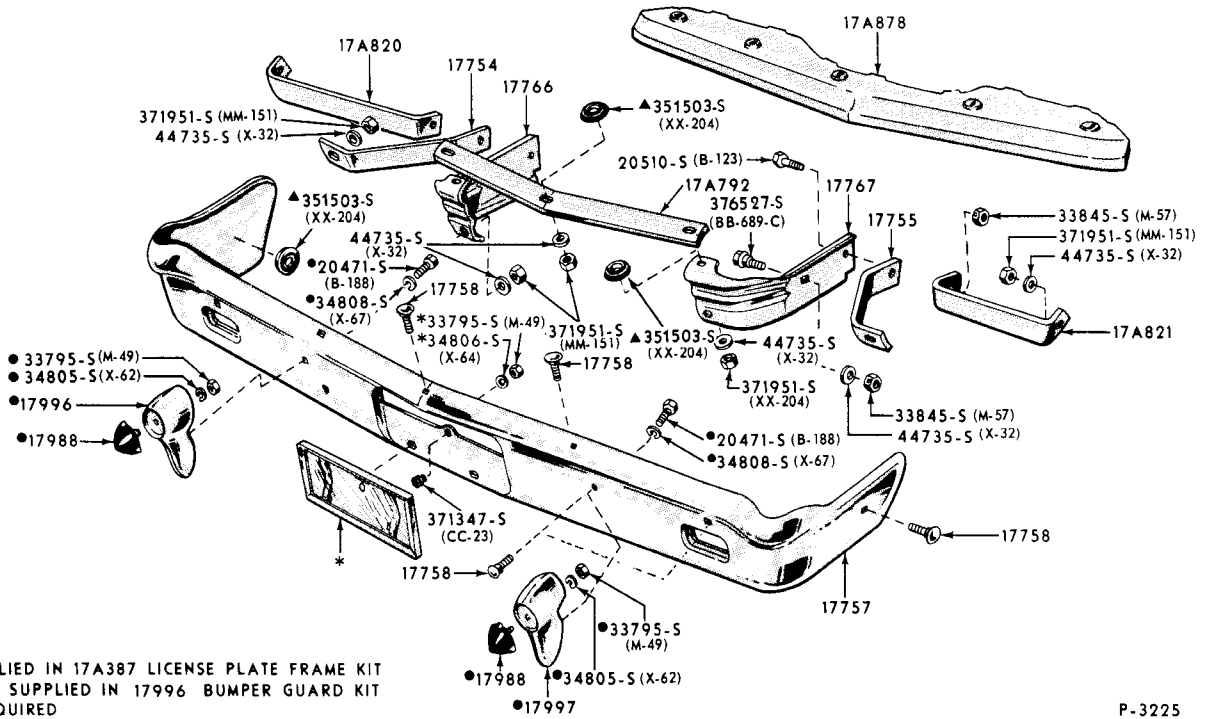

P-3225

FRONT BUMPER and RELATED PARTS  
 1961/62 FORD

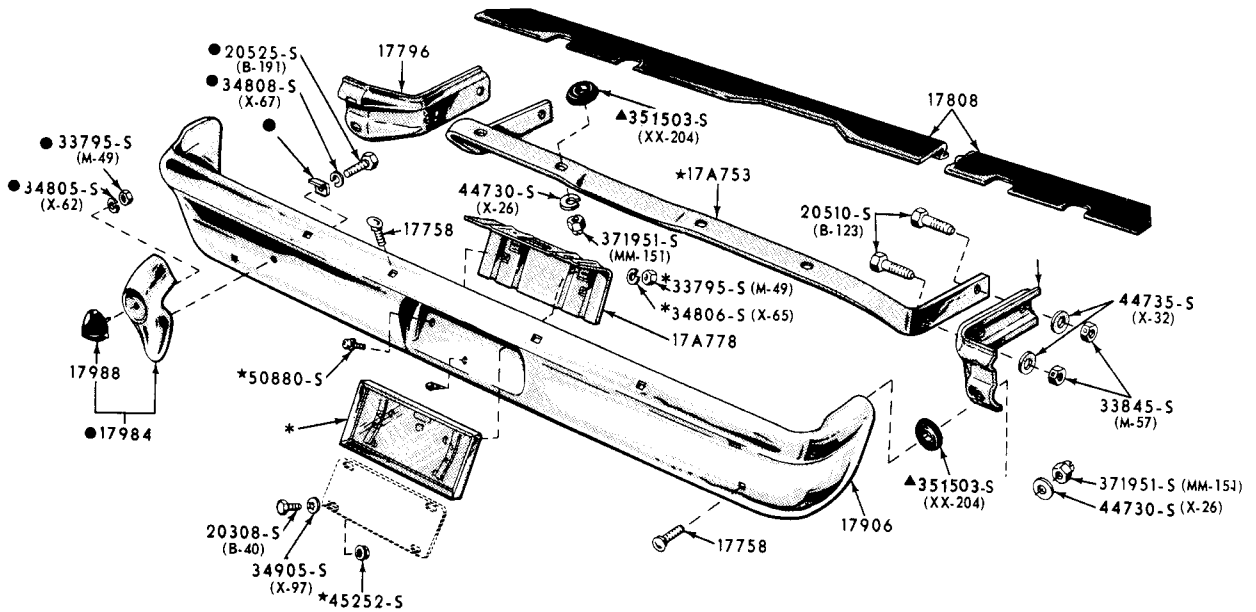

\* SUPPLIED IN 17A387 LICENSE PLATE FRAME KIT  
 ● ALSO SUPPLIED IN 17984 BUMPER GUARD KIT  
 ▲ 6 REQUIRED

P-3226

1961 REAR BUMPER & RELATED PARTS (FORD)-EXCEPT WITH SPARE WHEEL CARRIER  
 FOR SPARE WHEEL CARRIER ILLUSTRATION, SEE ILLUSTRATION SECTION 10



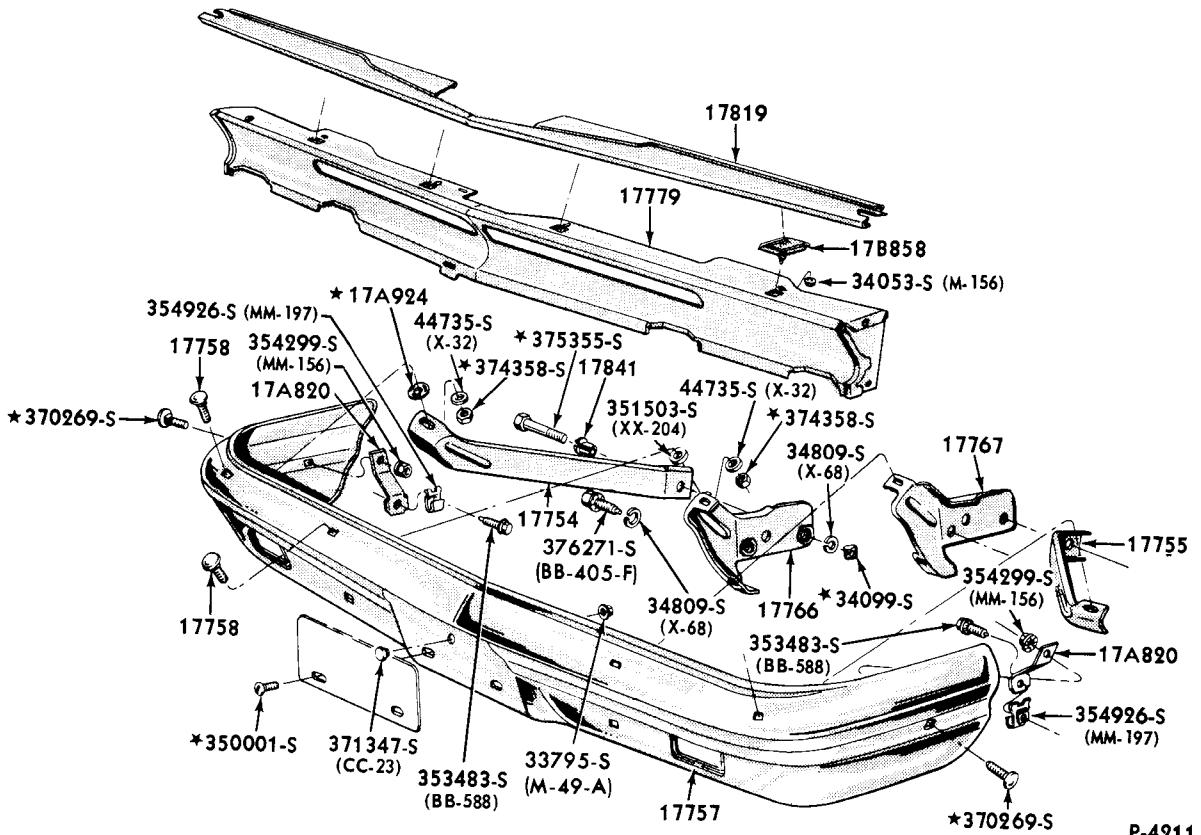

1964 FRONT BUMPER and RELATED PARTS (FAIRLANE)

P-4211

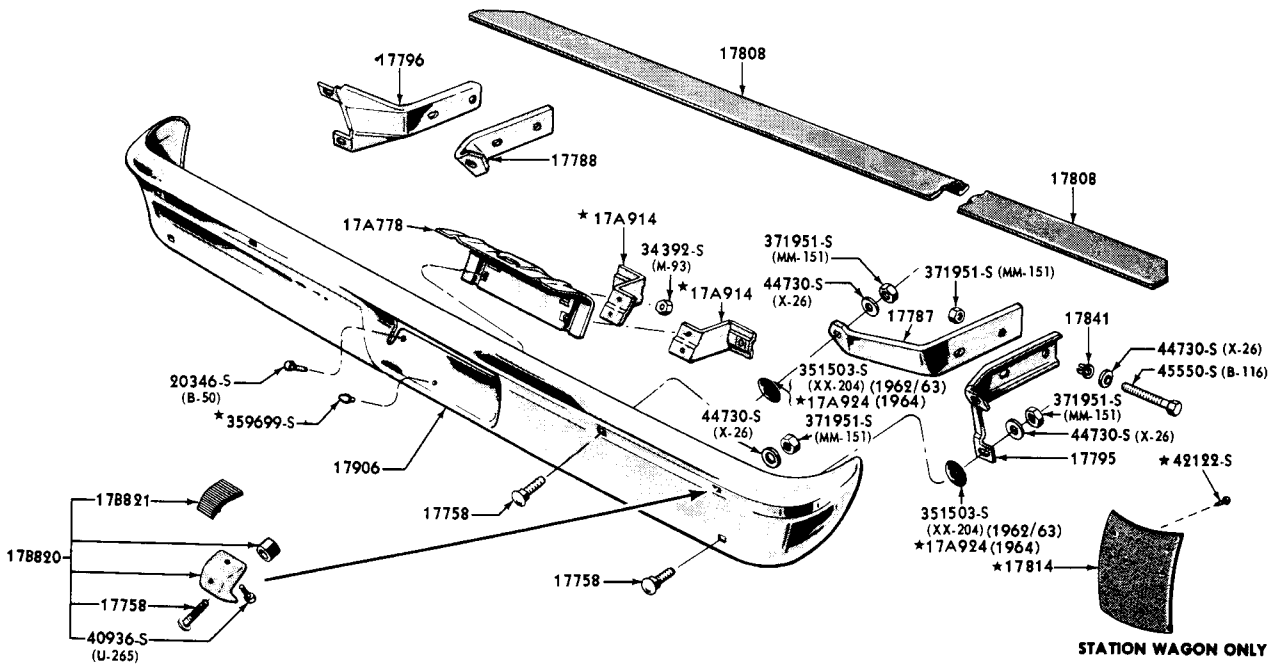

1962/64 REAR BUMPER and RELATED PARTS (FAIRLANE)

P-3646



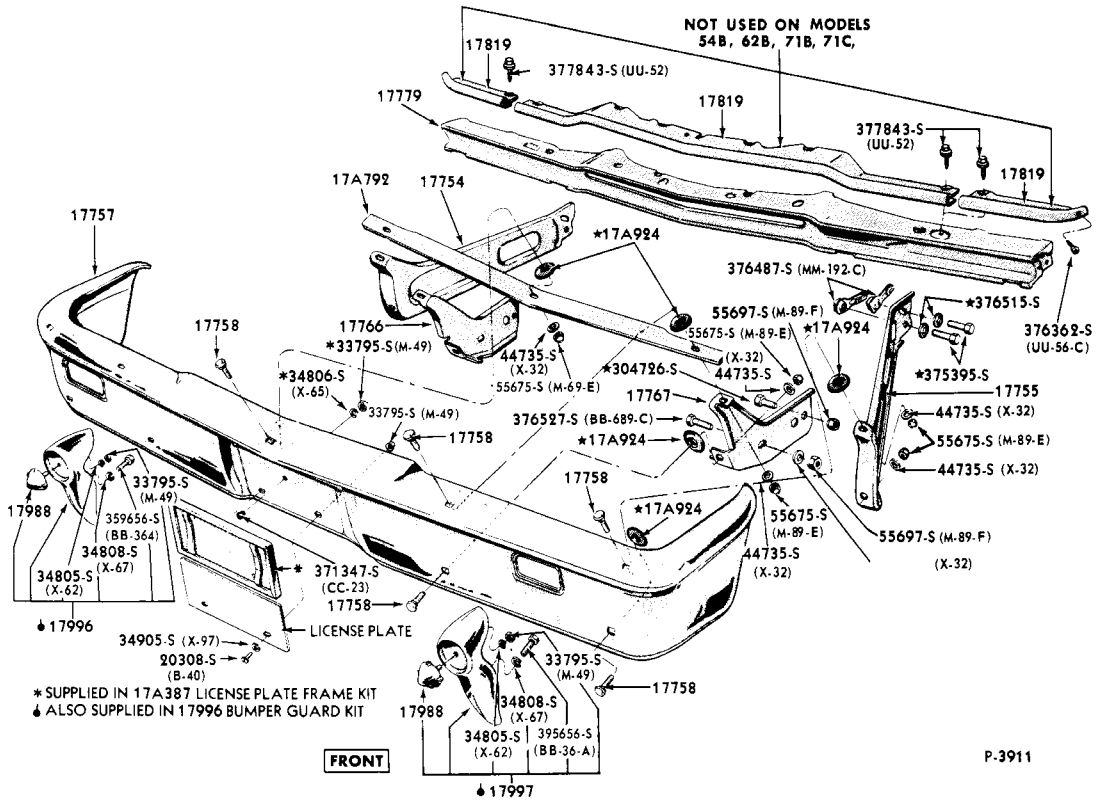

1963 FRONT BUMPER and RELATED PARTS (FORD)

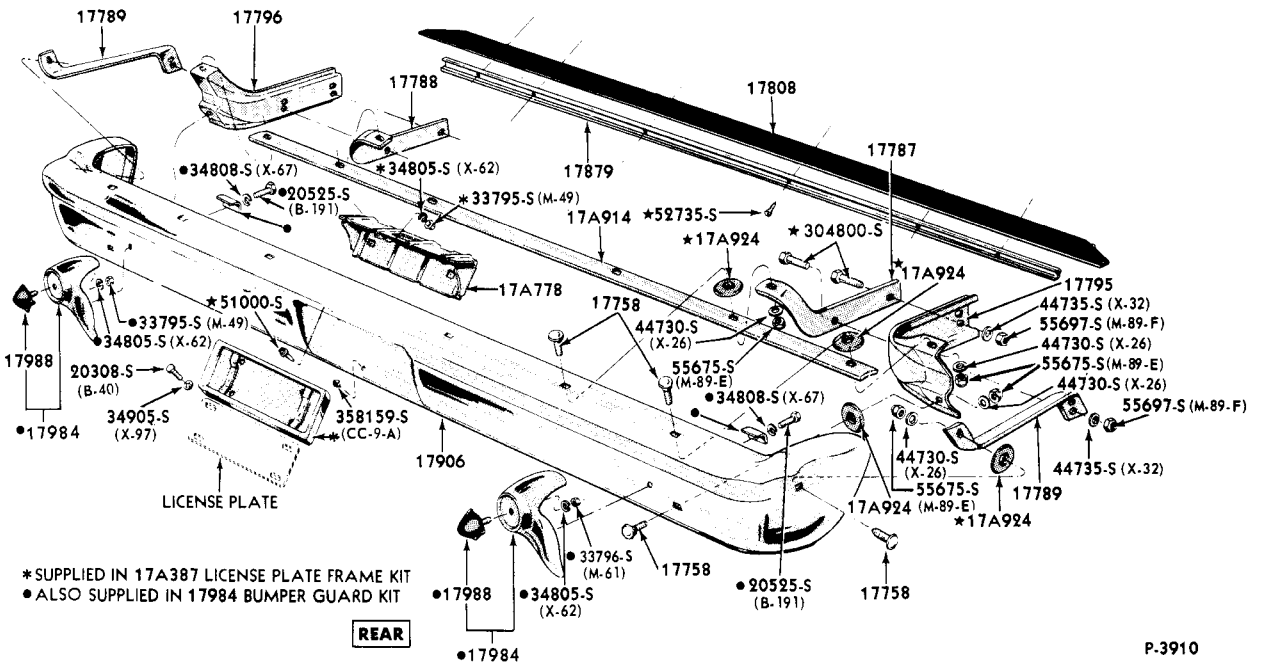

1963 REAR BUMPER and RELATED PARTS (FORD)



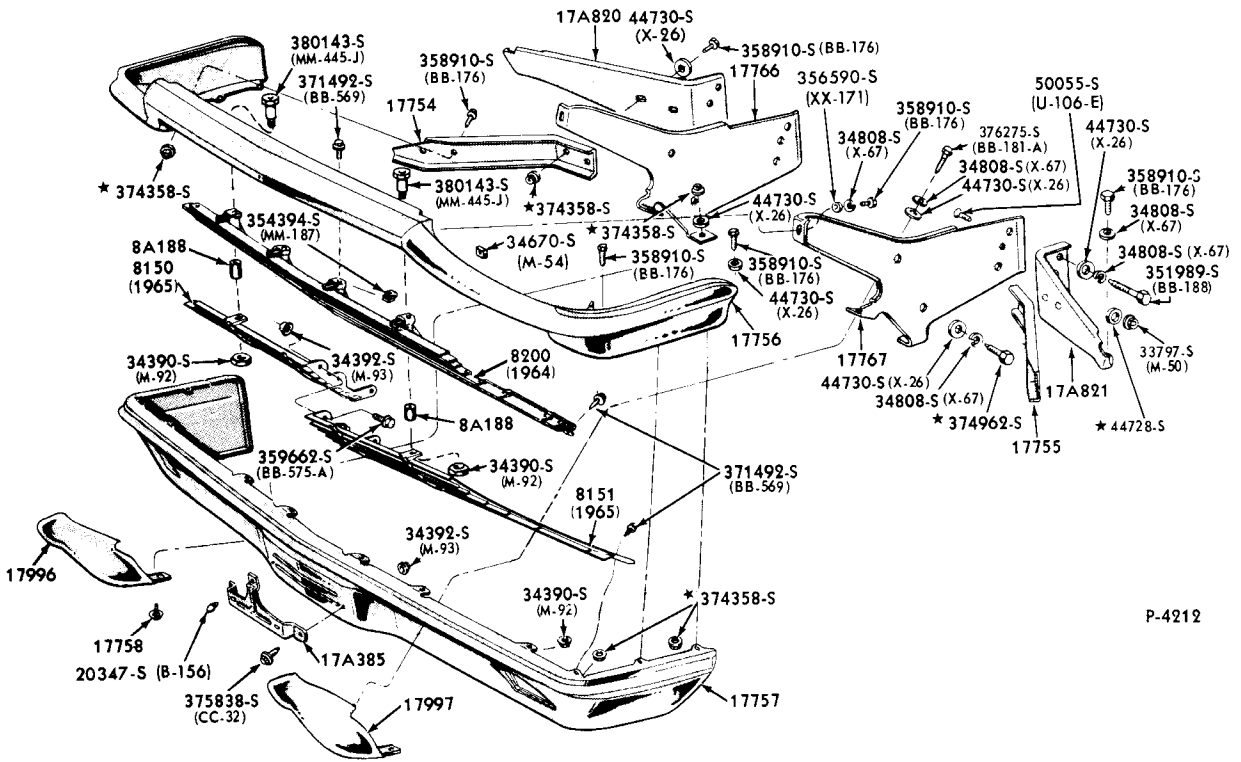

1964/ FRONT BUMPER, RADIATOR GRILLE and RELATED PARTS (THUNDERBIRD)

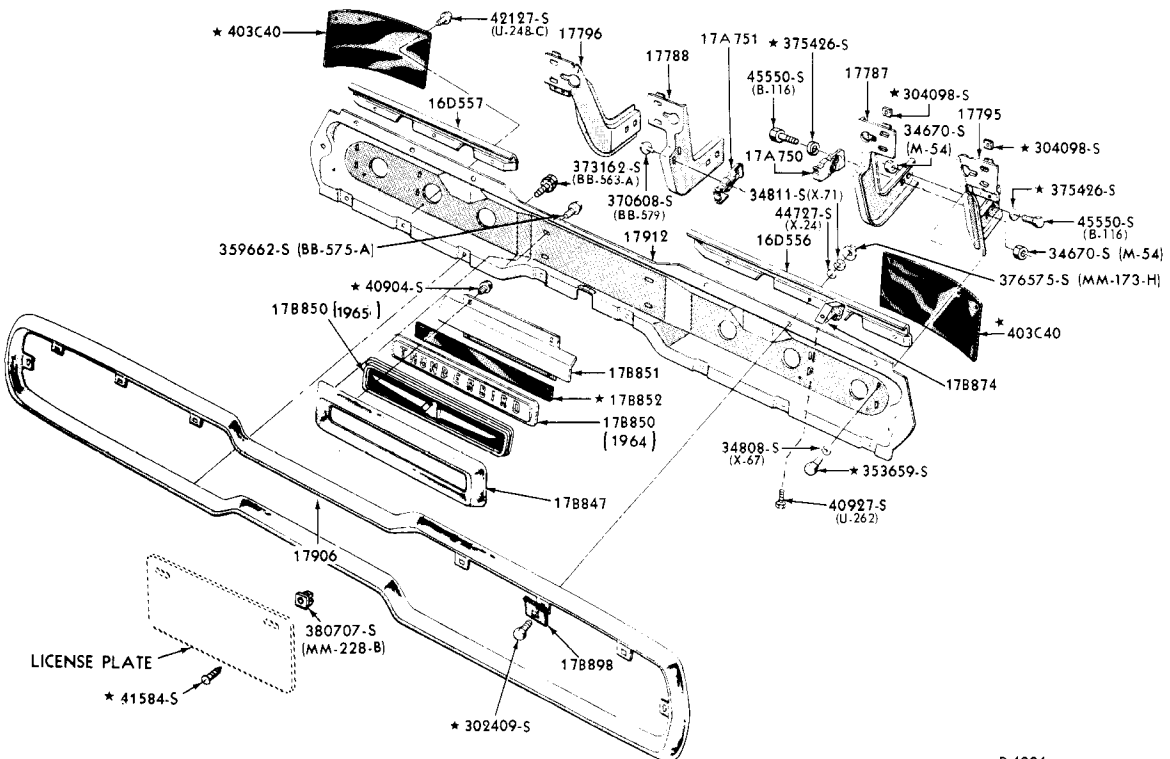

1964/ REAR BUMPER & RELATED PARTS (THUNDERBIRD)

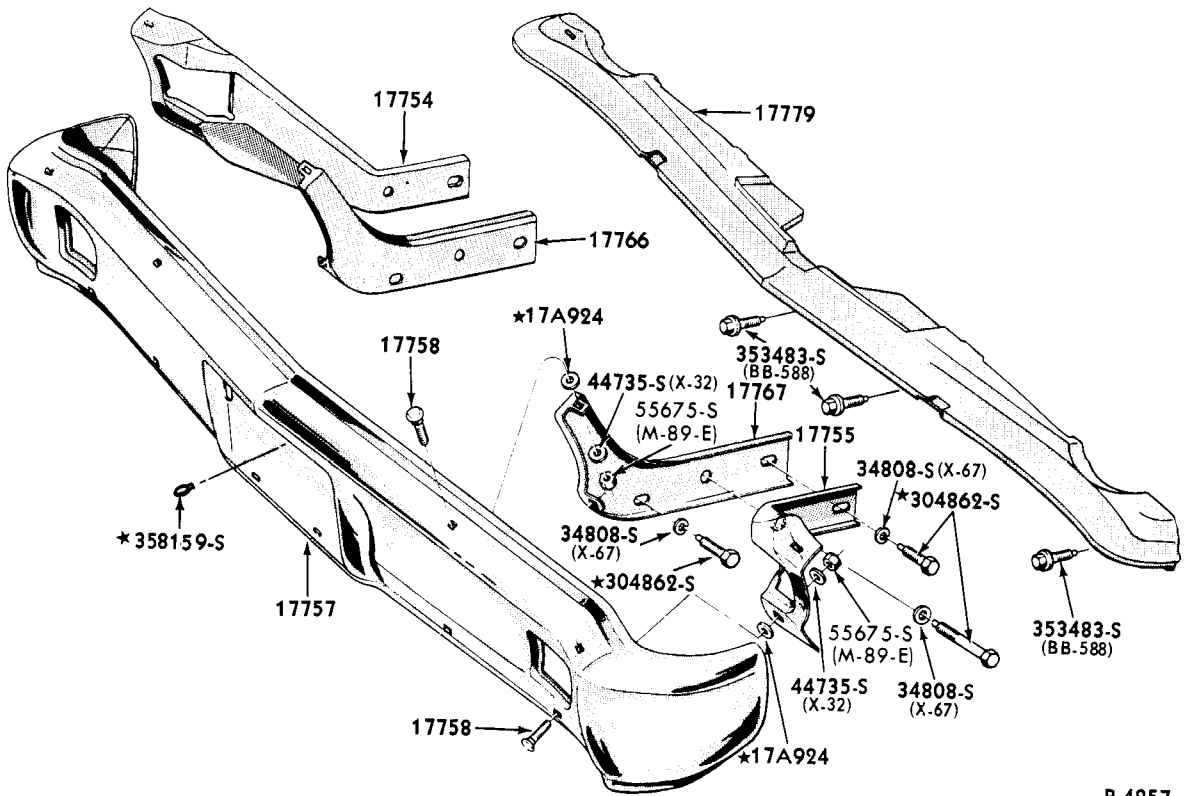

P-4257

1964/ FRONT BUMPER and RELATED PARTS (FALCON)

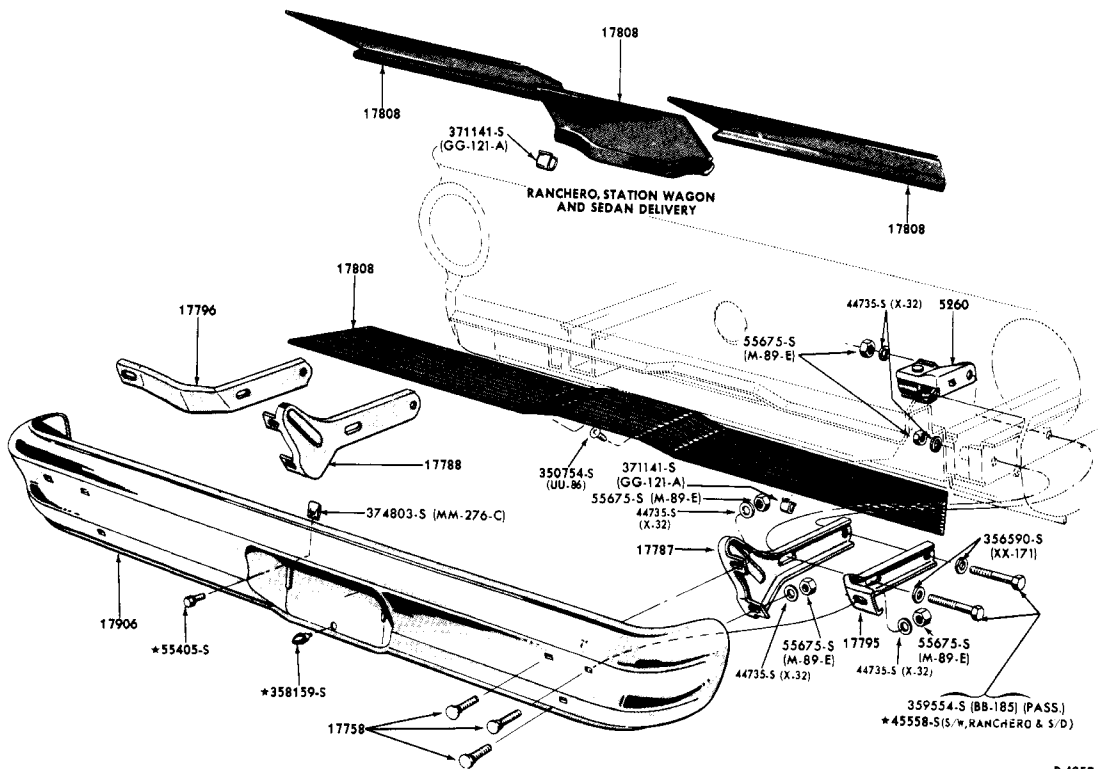

1964/ REAR BUMPER and RELATED PARTS (FALCON)

P-4259

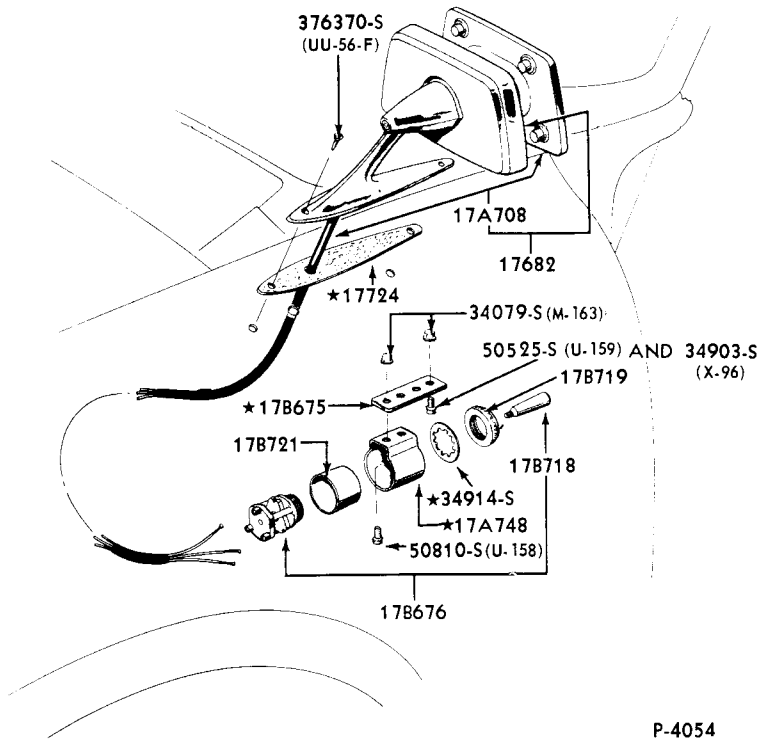

P-4054

1963 REMOTE CONTROL REAR VIEW MIRROR-FENDER MOUNTED (FAIRLANE, FALCON, FORD)

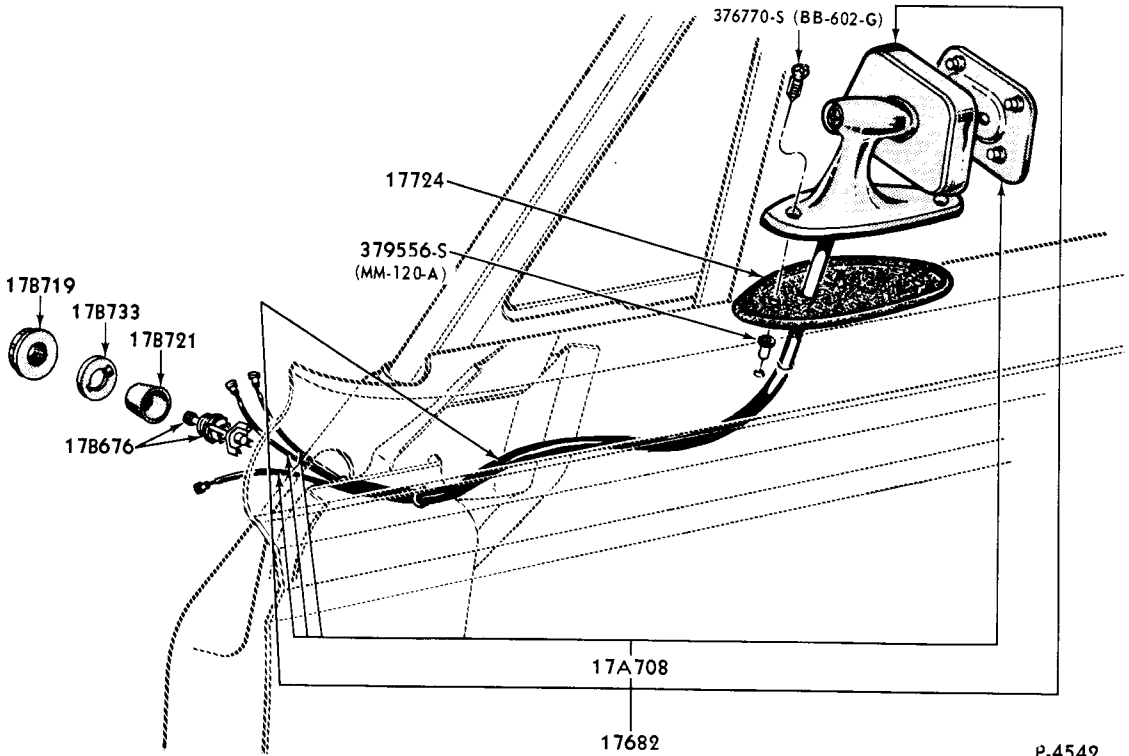

P-4542

1963/ REMOTE CONTROL REAR VIEW MIRROR-DOOR MOUNTED (FORD)

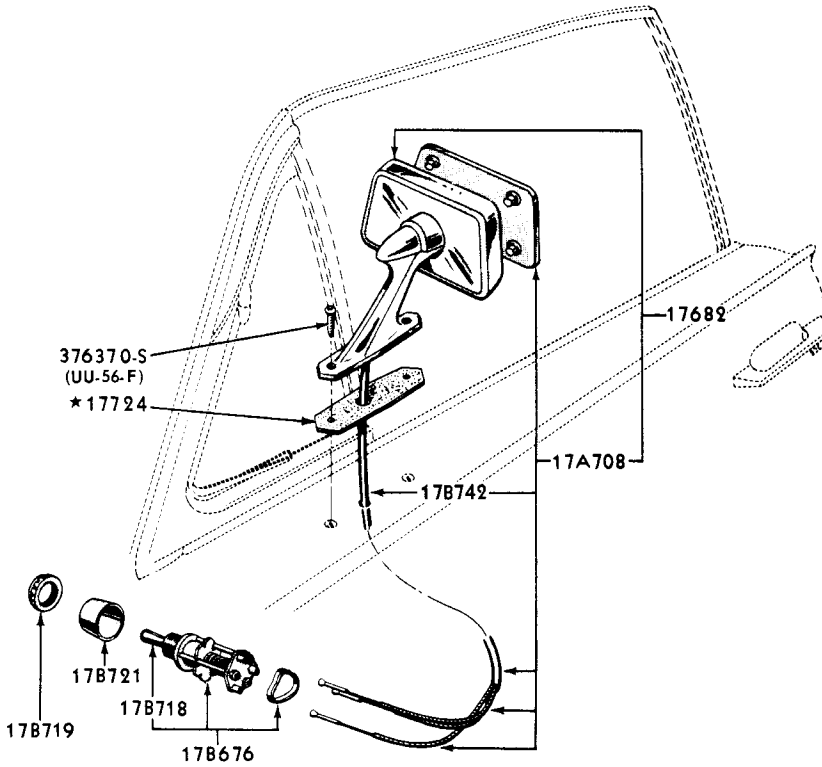

P-4098

1963 REMOTE CONTROL REAR VIEW MIRROR (THUNDERBIRD)

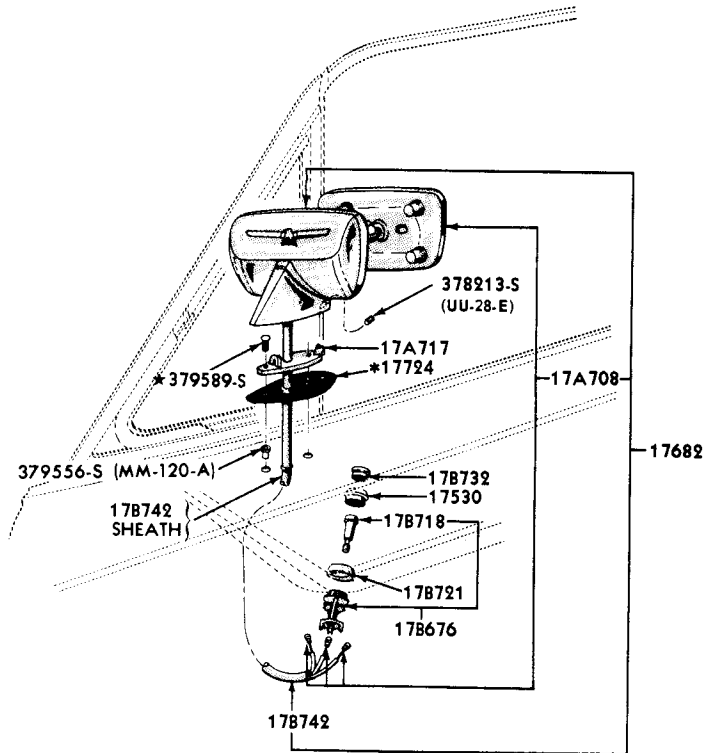

P-4541

\* ALSO SUPPLIED WITH 17682 MIRROR ASSEMBLY

1964/ REMOTE CONTROL REAR VIEW MIRROR (THUNDERBIRD)

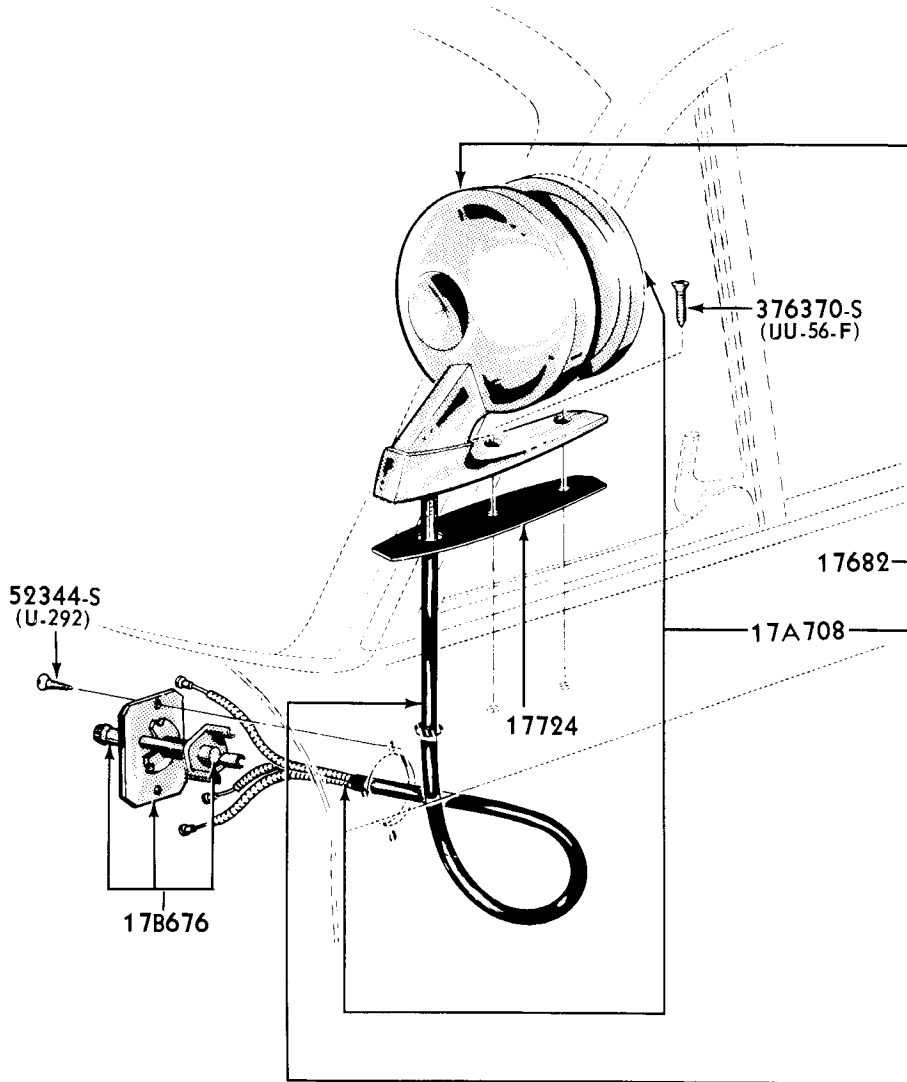

P-4543

REMOTE CONTROL REAR VIEW MIRROR  
1964 FAIRLANE & FALCON

**FORD CAR PARTS**

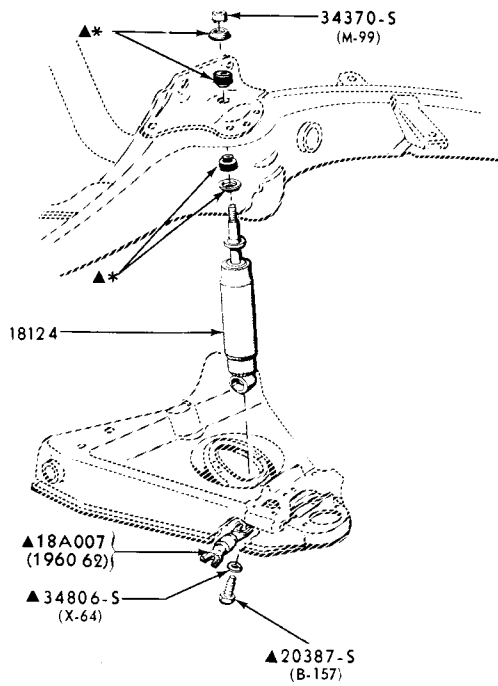

▲ ALSO SUPPLIED IN 18124 SHOCK ABSORBER KIT  
\* SUPPLIED IN 18198 BUSHING REPAIR KIT

P-2977

1960/64 SHOCK ABSORBER-FRONT (FORD)

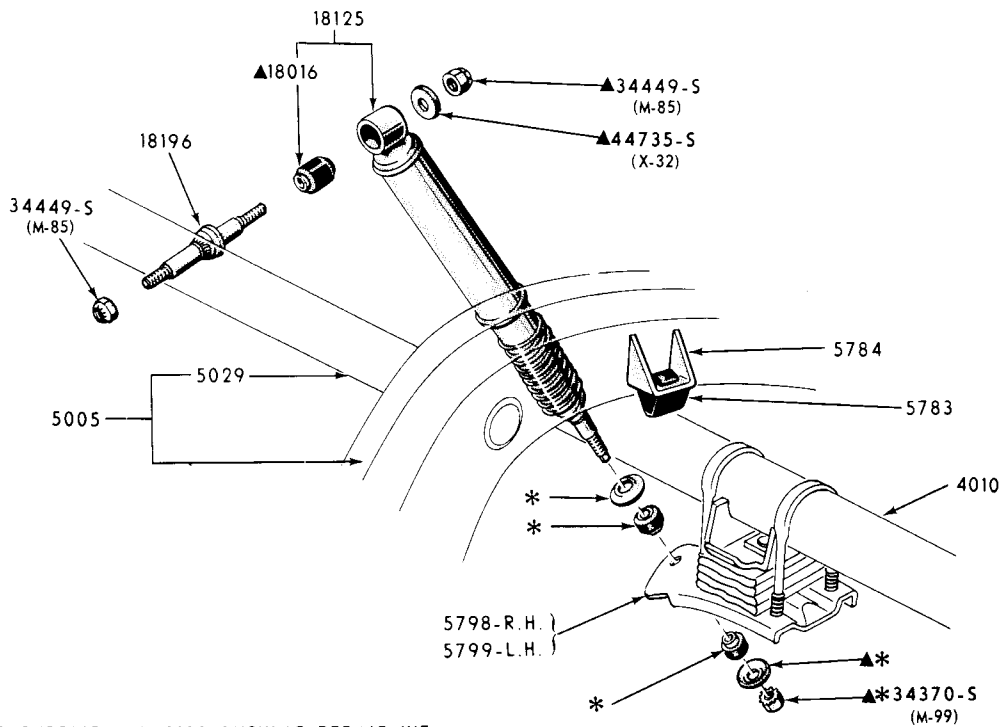

\* SUPPLIED IN 18198 BUSHING REPAIR KIT  
▲ ALSO SUPPLIED IN 18125 SHOCK ABSORBER KIT

P-2984

1960/64 SHOCK ABSORBER-REAR (FORD)



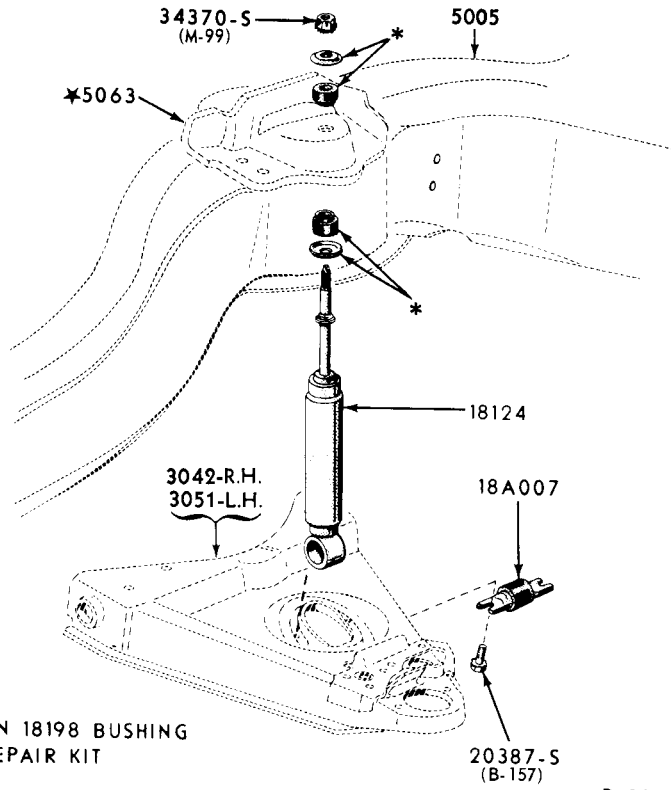

\*SUPPLIED IN 18198 BUSHING REPAIR KIT

P-3091

1960 SHOCK ABSORBER-FRONT (THUNDERBIRD)

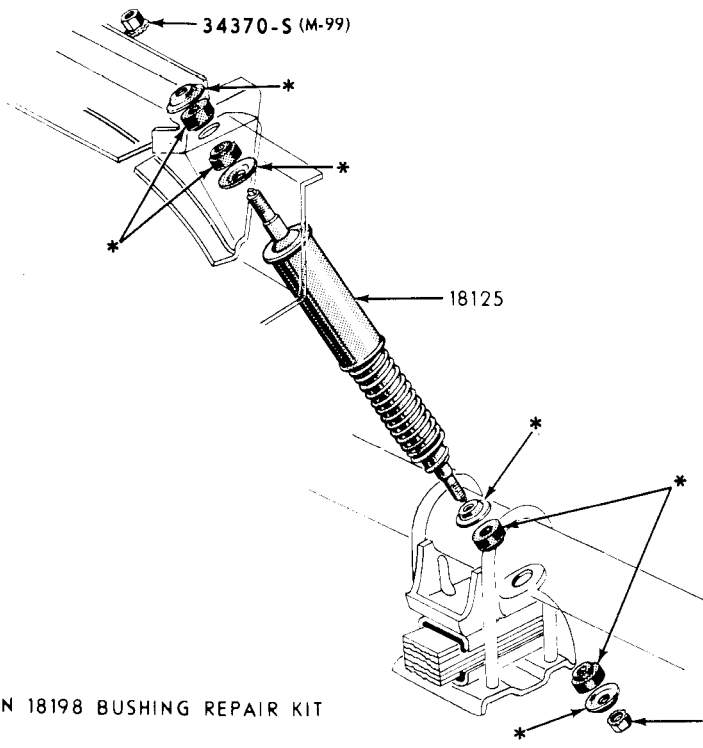

\* SUPPLIED IN 18198 BUSHING REPAIR KIT

P-3065

1960 SHOCK ABSORBER-REAR (THUNDERBIRD)



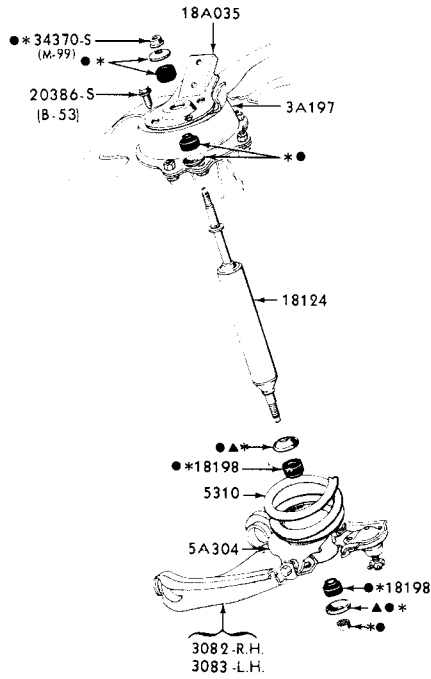

- \* SUPPLIED IN 18198 BUSHING REPAIR KIT
- ▲ SUPPLIED IN 18A057 WASHER KIT
- ALSO SUPPLIED IN 18124 SHOCK ABSORBER KIT

P-3276

1961/62 SHOCK ABSORBER-FRONT (THUNDERBIRD)

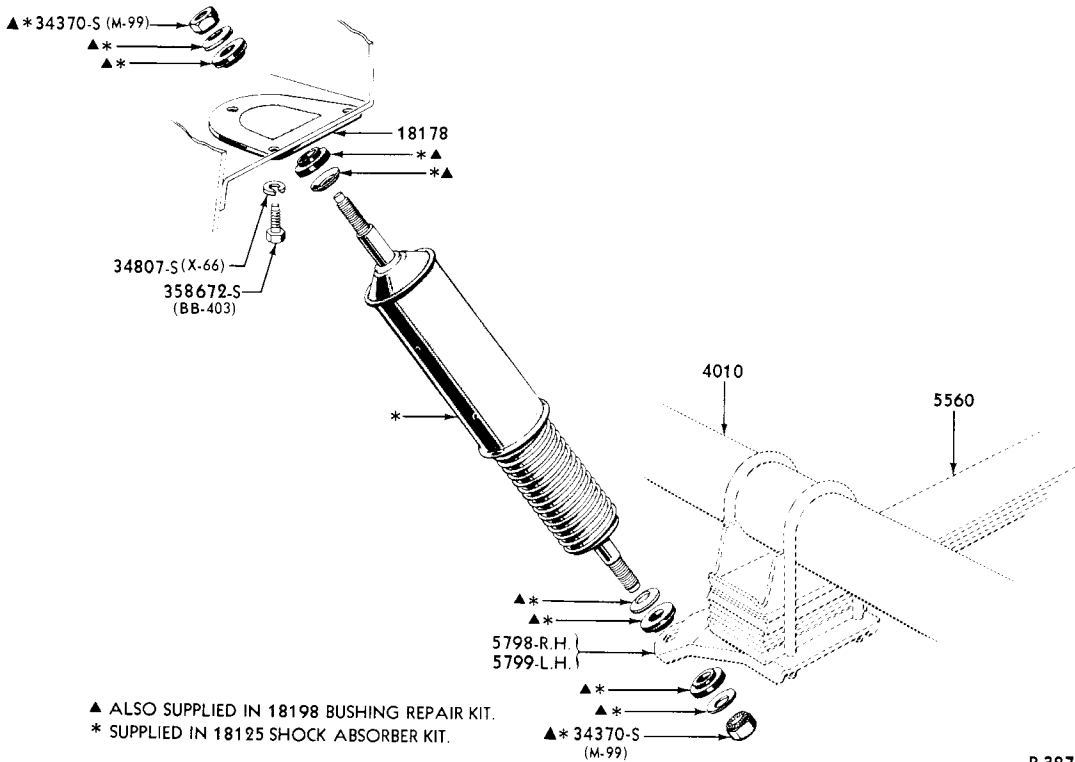

- ▲ ALSO SUPPLIED IN 18198 BUSHING REPAIR KIT.
- \* SUPPLIED IN 18125 SHOCK ABSORBER KIT.

- ▲ \* 34370-S (M-99)

P-3278

1961/63 SHOCK ABSORBER-REAR (THUNDERBIRD)-TYPICAL

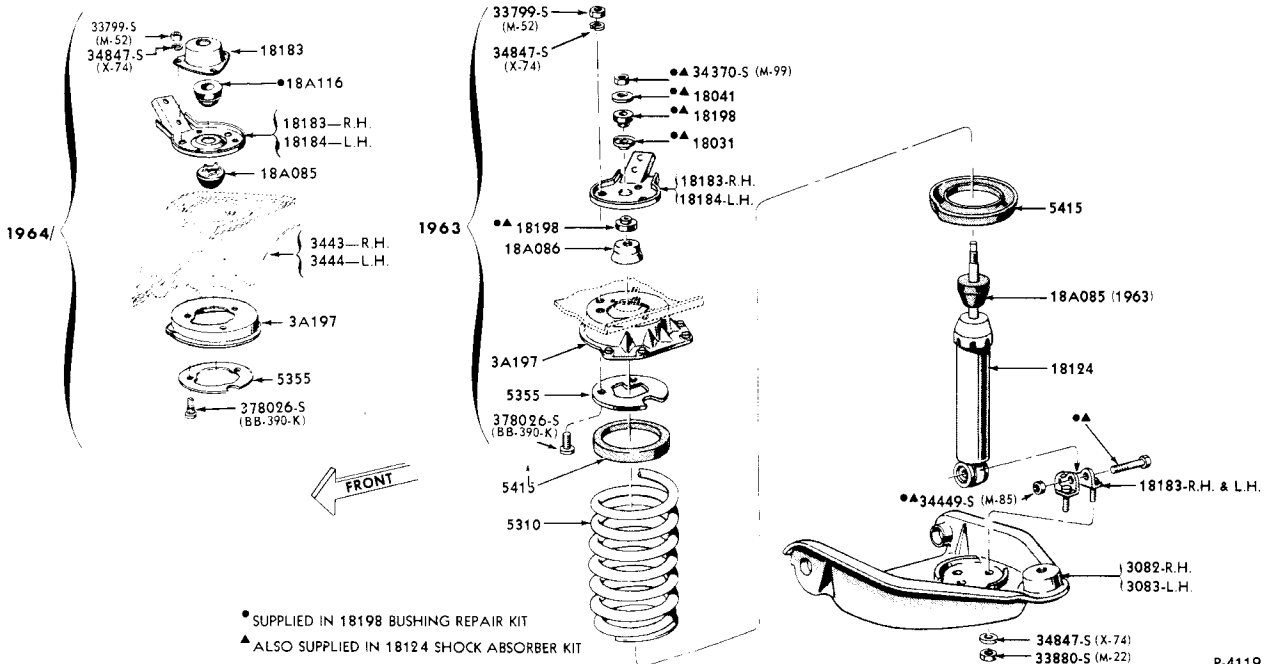

P-4119

1963/ SHOCK ABSORBER-FRONT (THUNDERBIRD)

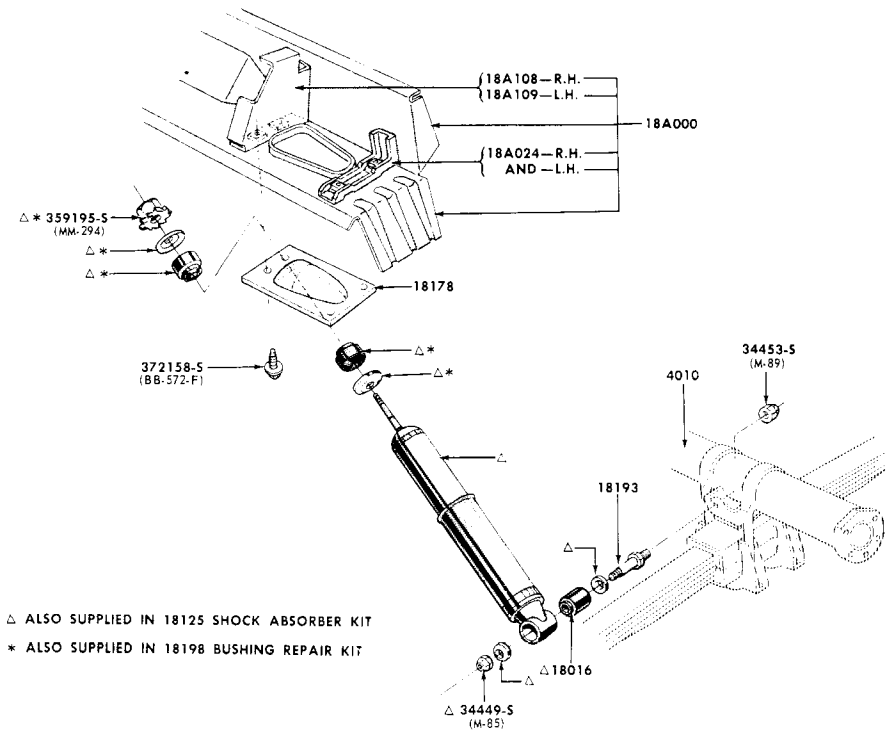

P-4352

1964/ SHOCK ABSORBER-REAR (THUNDERBIRD)



1960 FRESH AIR HEATER and RELATED PARTS (THUNDERBIRD)

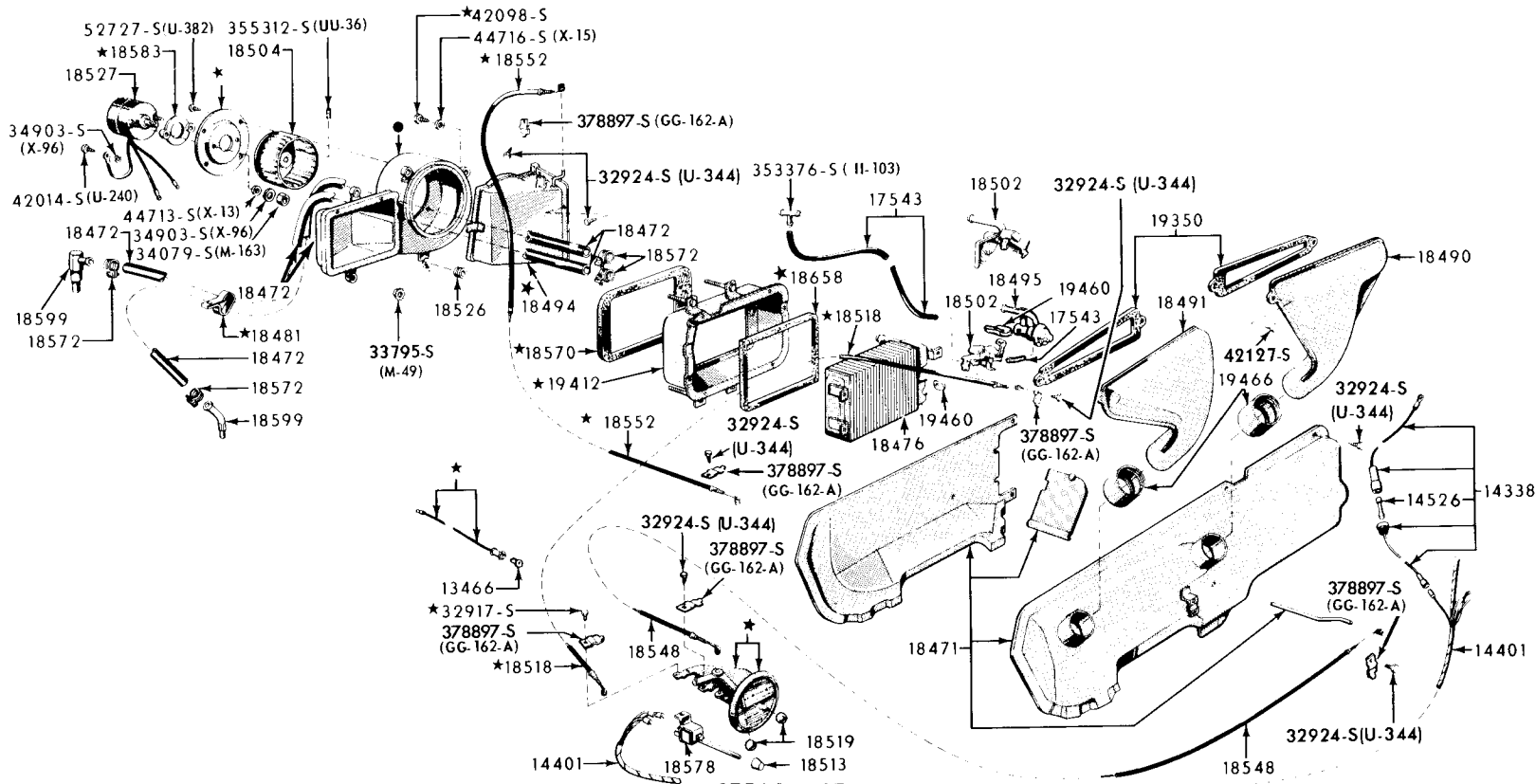



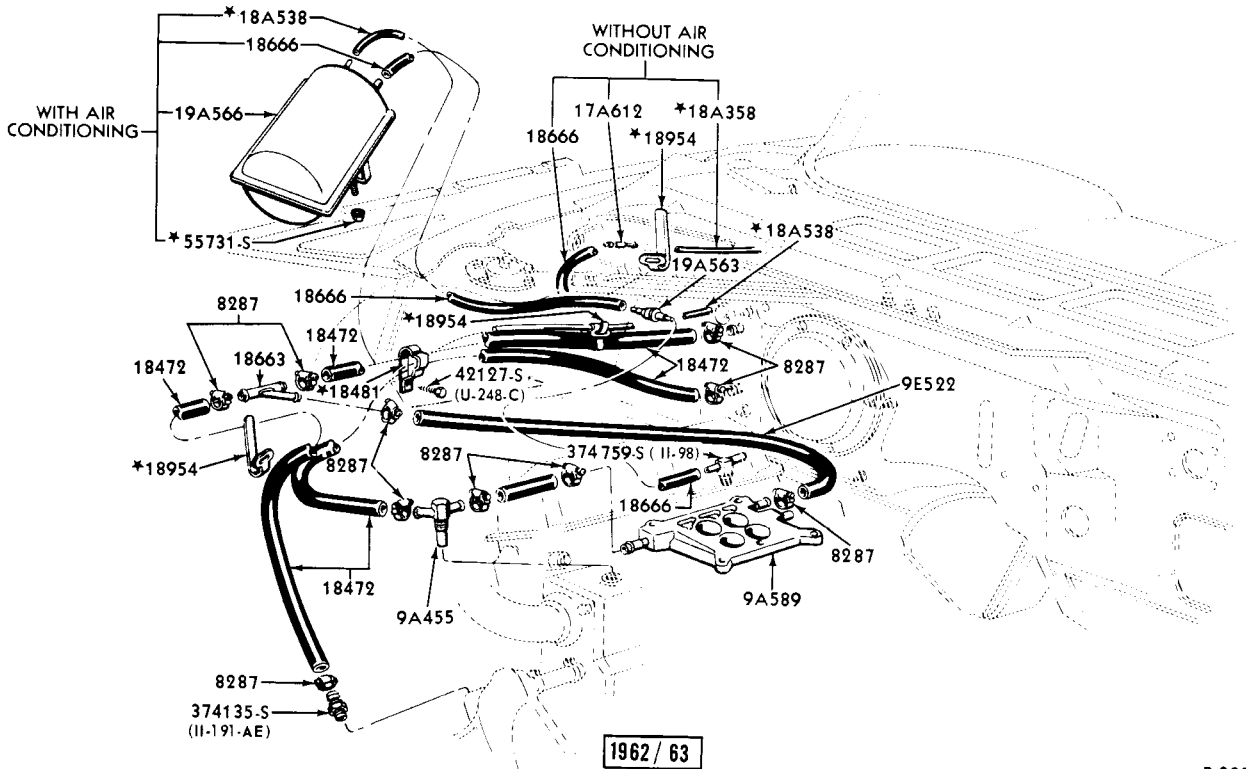
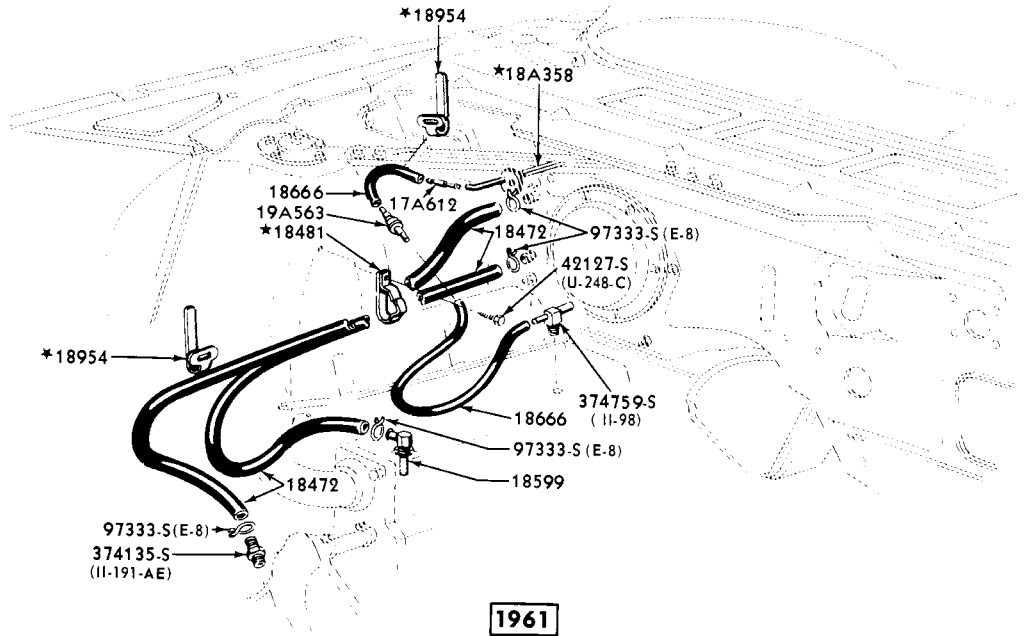













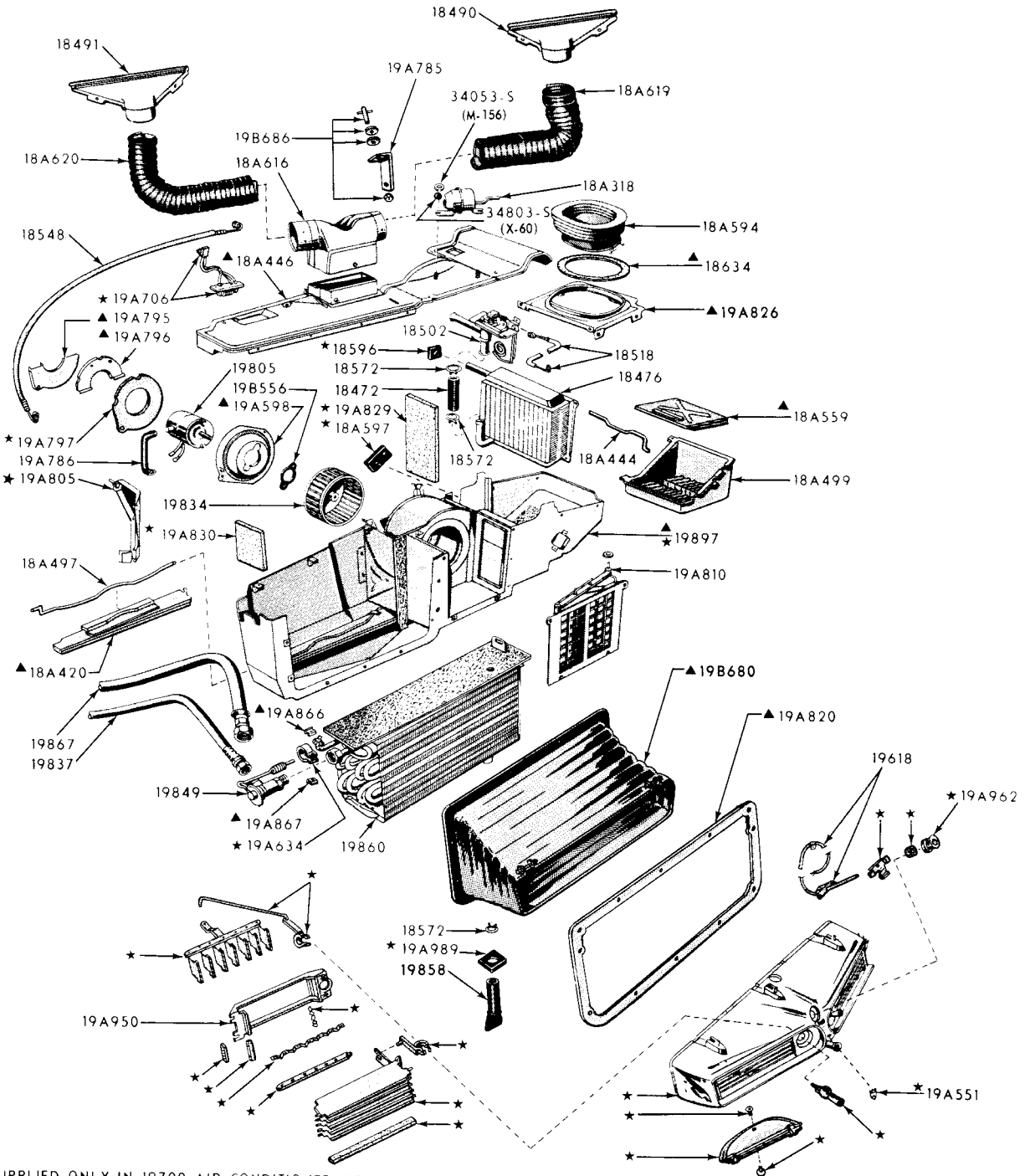

▲ SUPPLIED ONLY IN 19700 AIR CONDITIONER KIT

P-3152

1960 FORD INTEGRAL AIR CONDITIONER EVAPORATOR, HEATER & RELATED PARTS

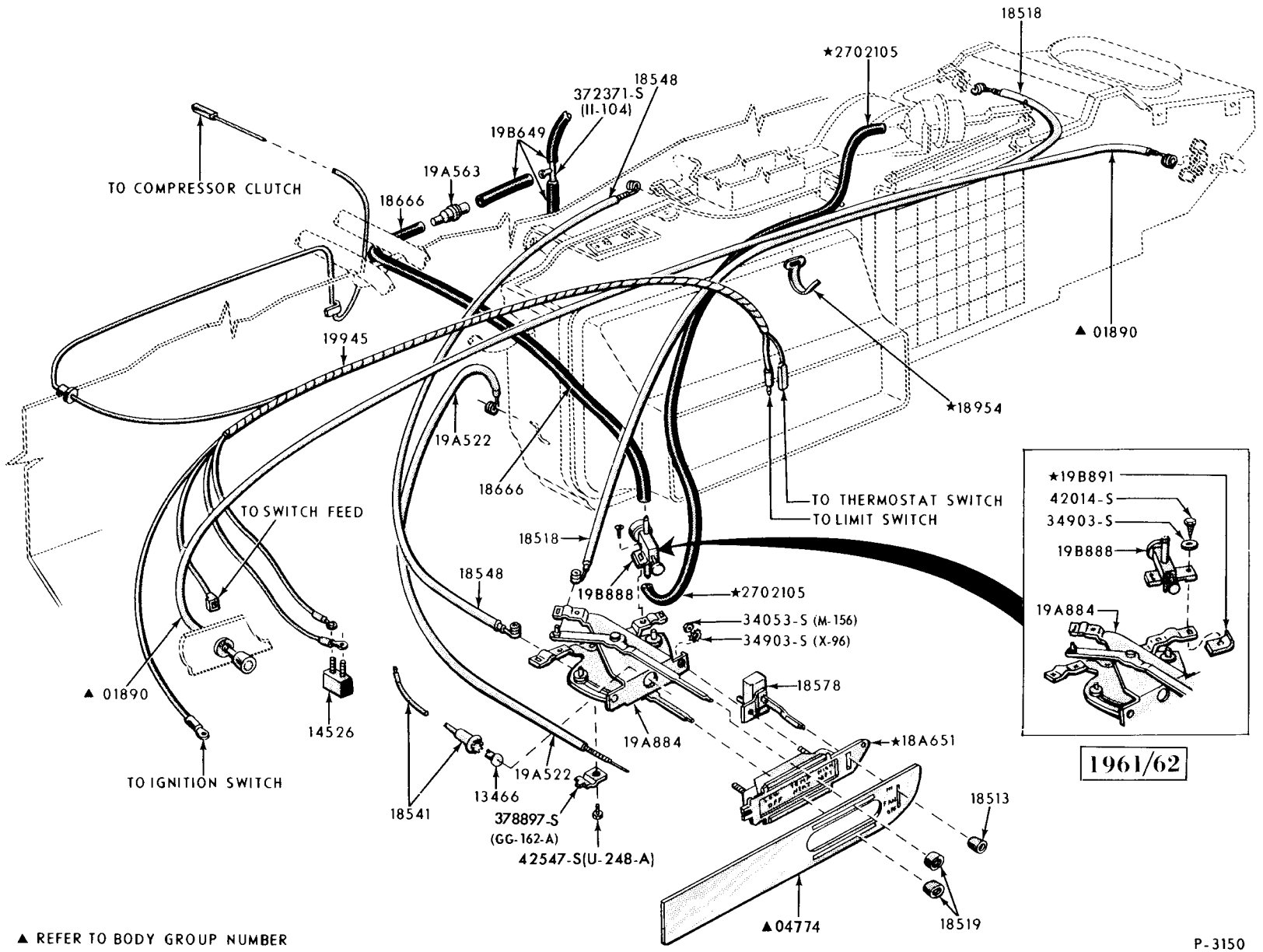

▲ REFER TO BODY GROUP NUMBER

1960 THUNDERBIRD INTEGRAL AIR CONDITIONER EVAPORATOR, BLOWER & RELATED PARTS

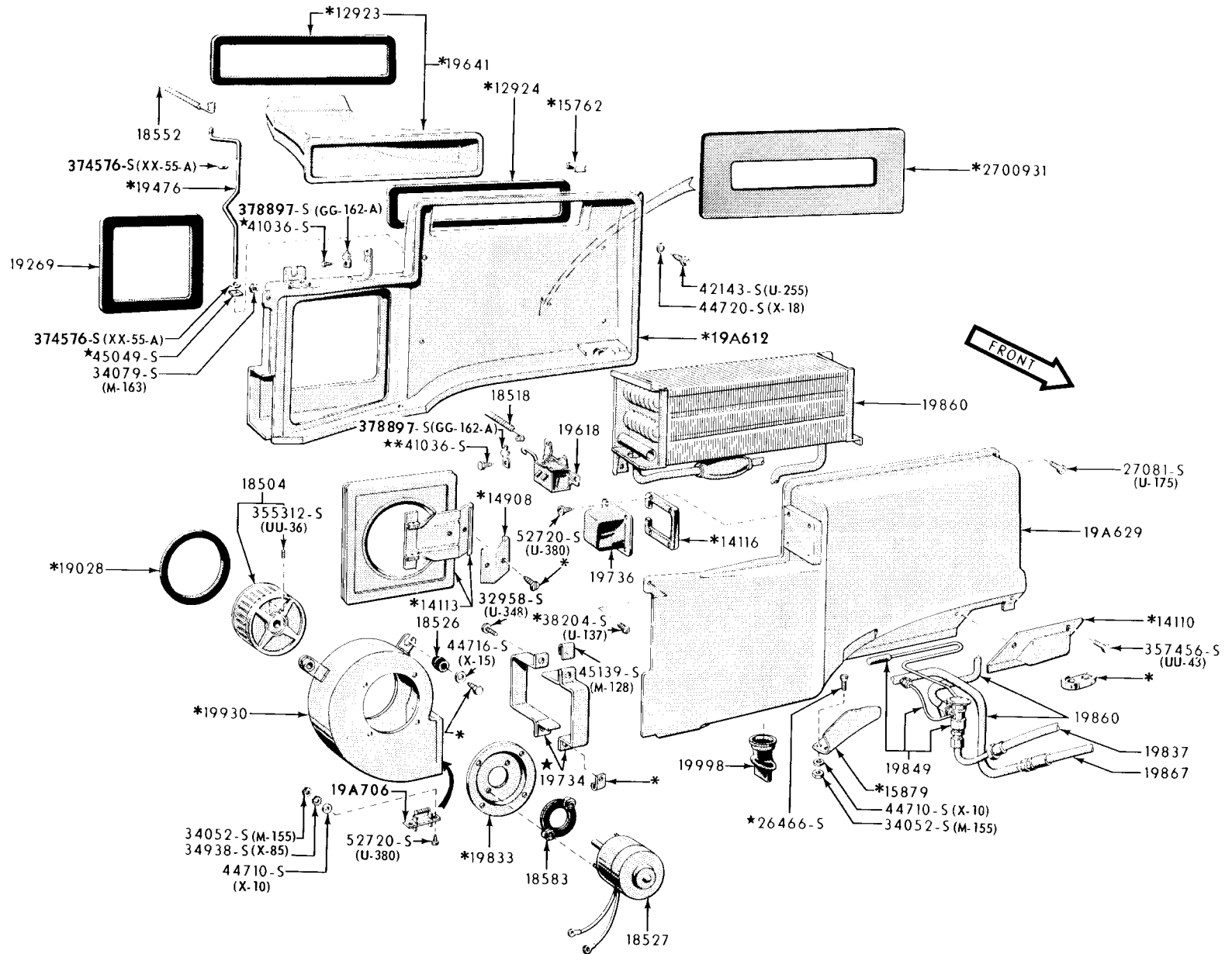

\*SUPPLIED IN 19700 AIR CONDITIONING KIT ONLY



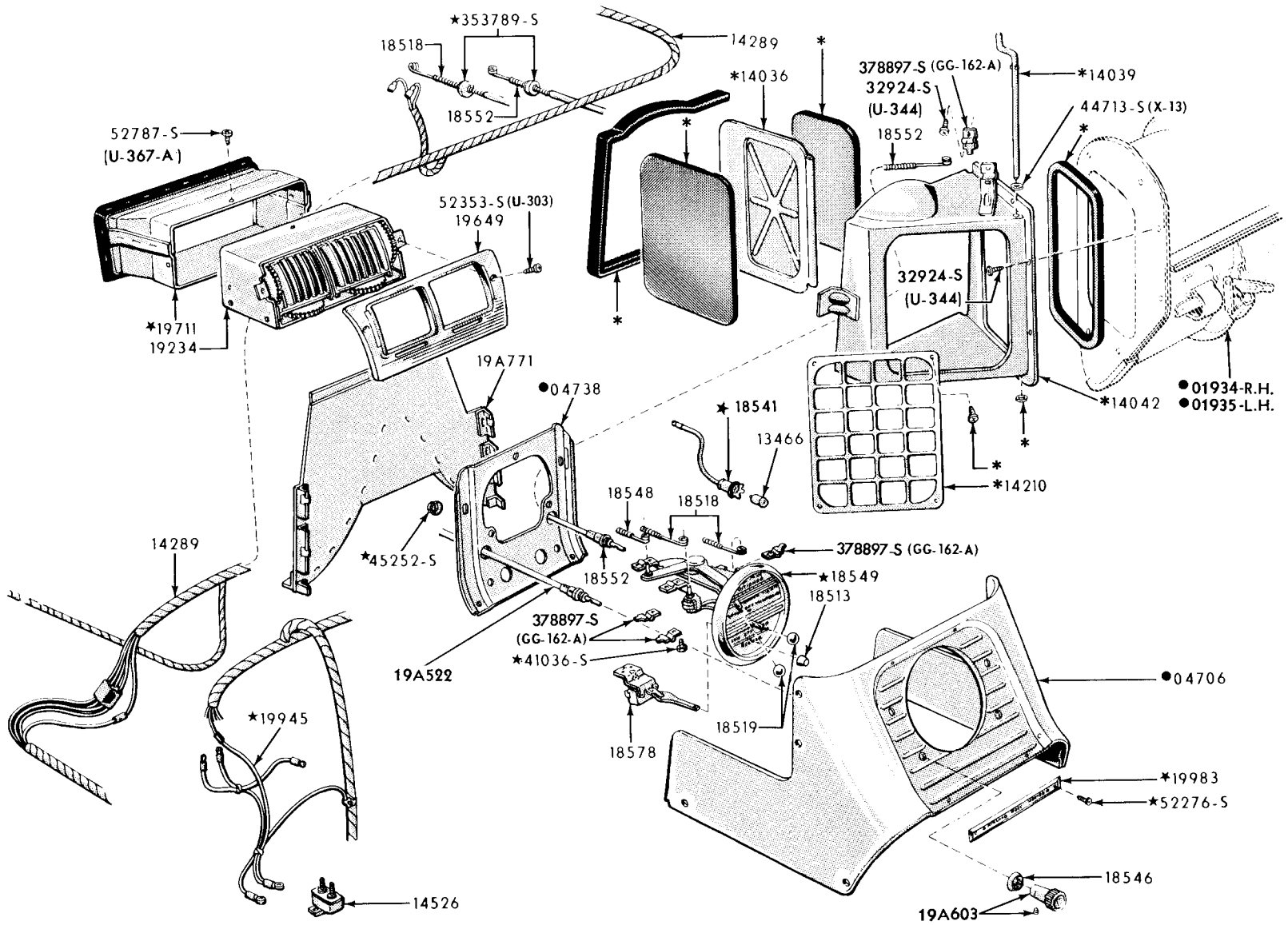

\*SUPPLIED IN 18494 VALVE ASSEMBLY ONLY  
 ●REFER TO BODY GROUP NUMBERS



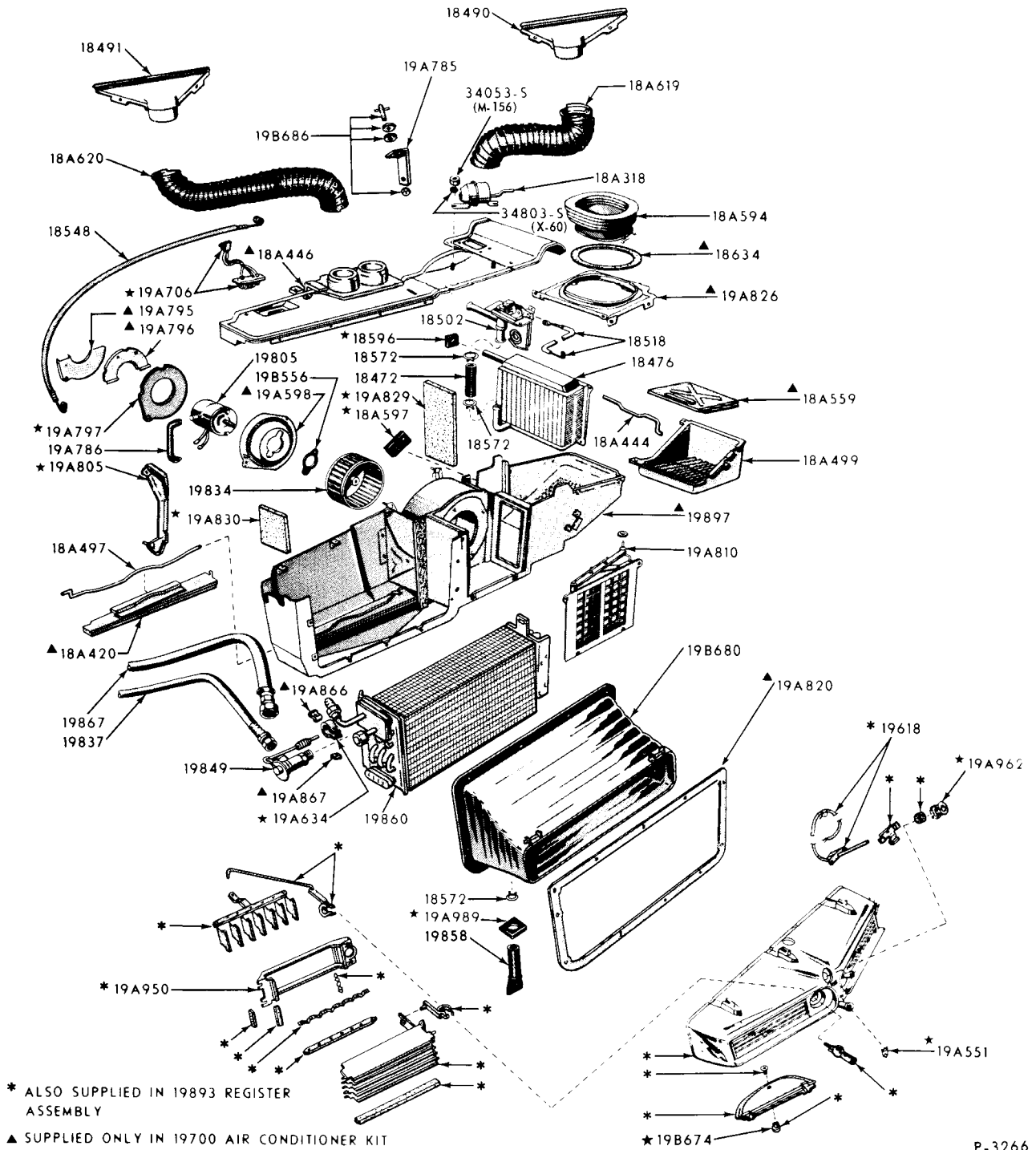

1961/63 THUNDERBIRD INTEGRAL AIR CONDITIONER EVAPORATOR, BLOWER & RELATED PARTS

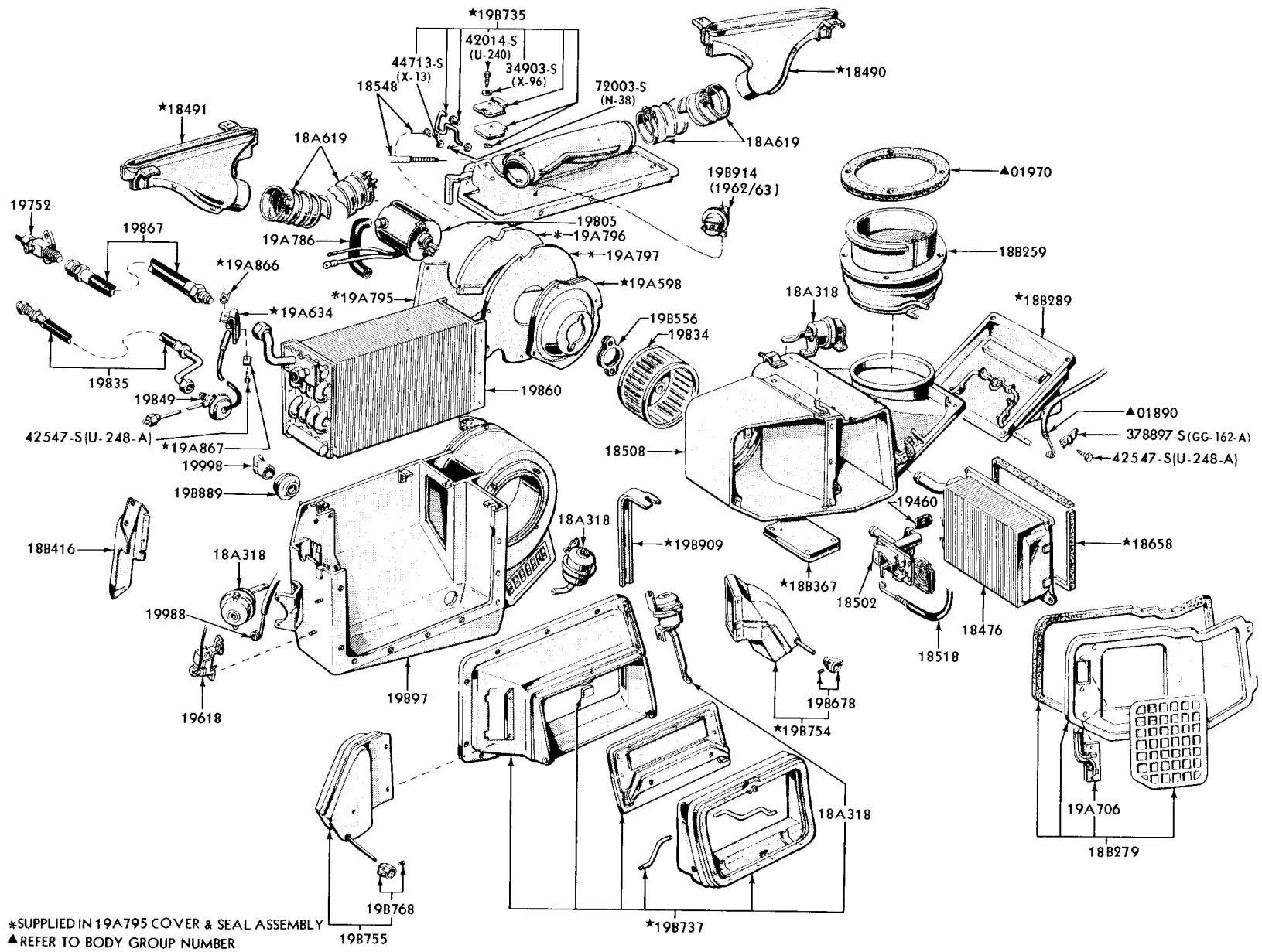

\*SUPPLIED IN 19A795 COVER & SEAL ASSEMBLY  
 ▲REFER TO BODY GROUP NUMBER

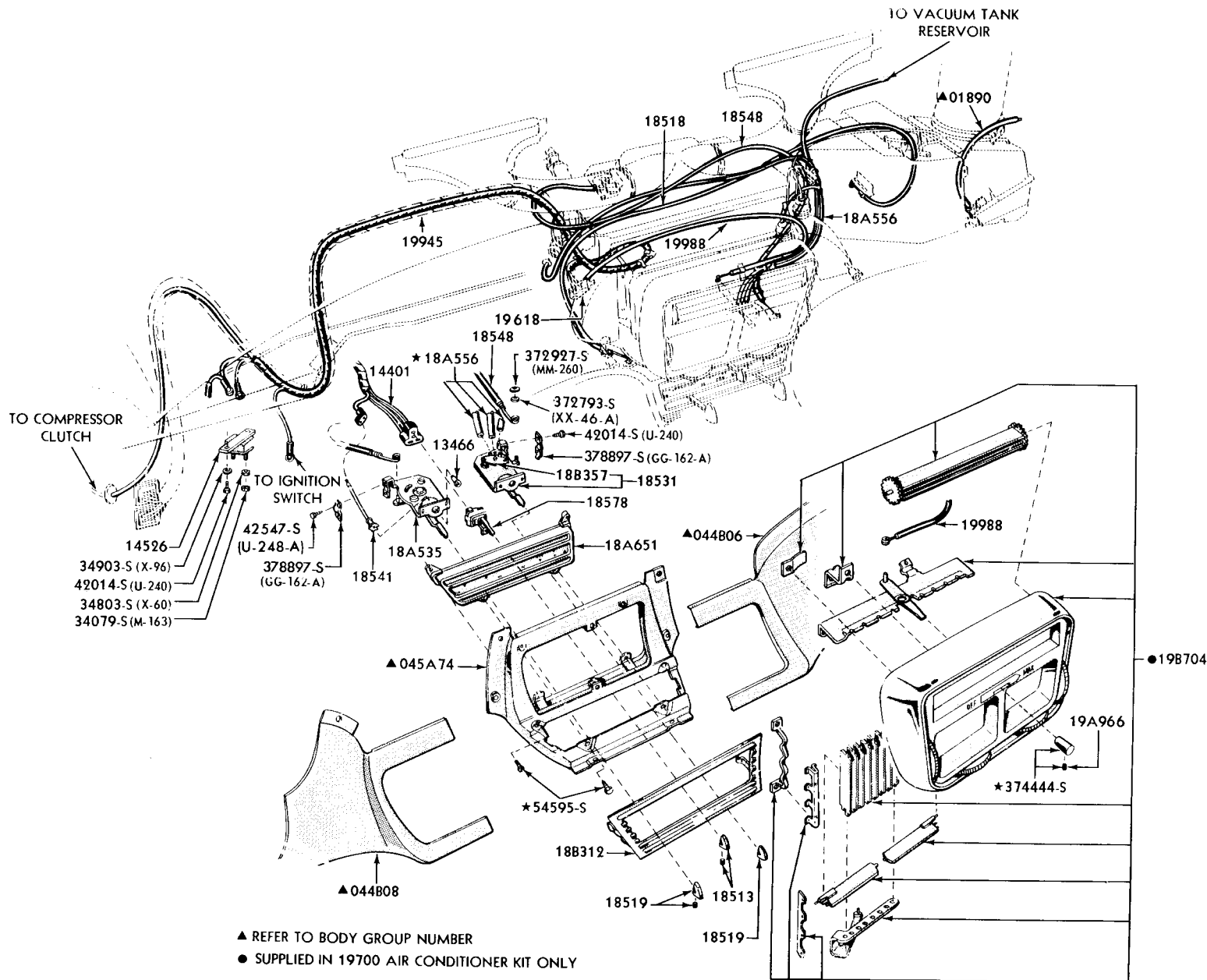

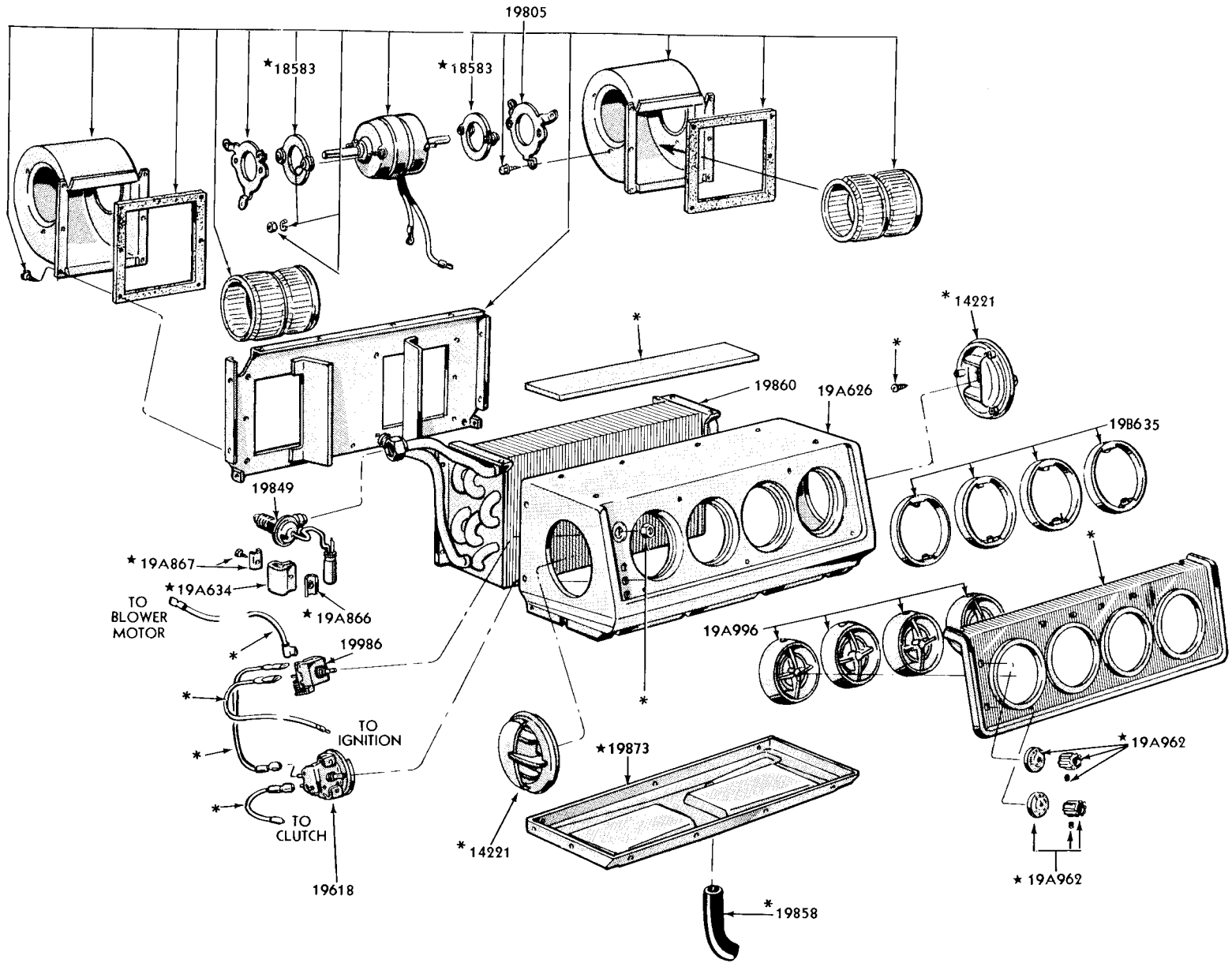

\* SUPPLIED IN 198970 KIT ONLY (GALAXIE)  
 \* SUPPLIED IN 19700 KIT ONLY (FAIRLANE & FALCON)

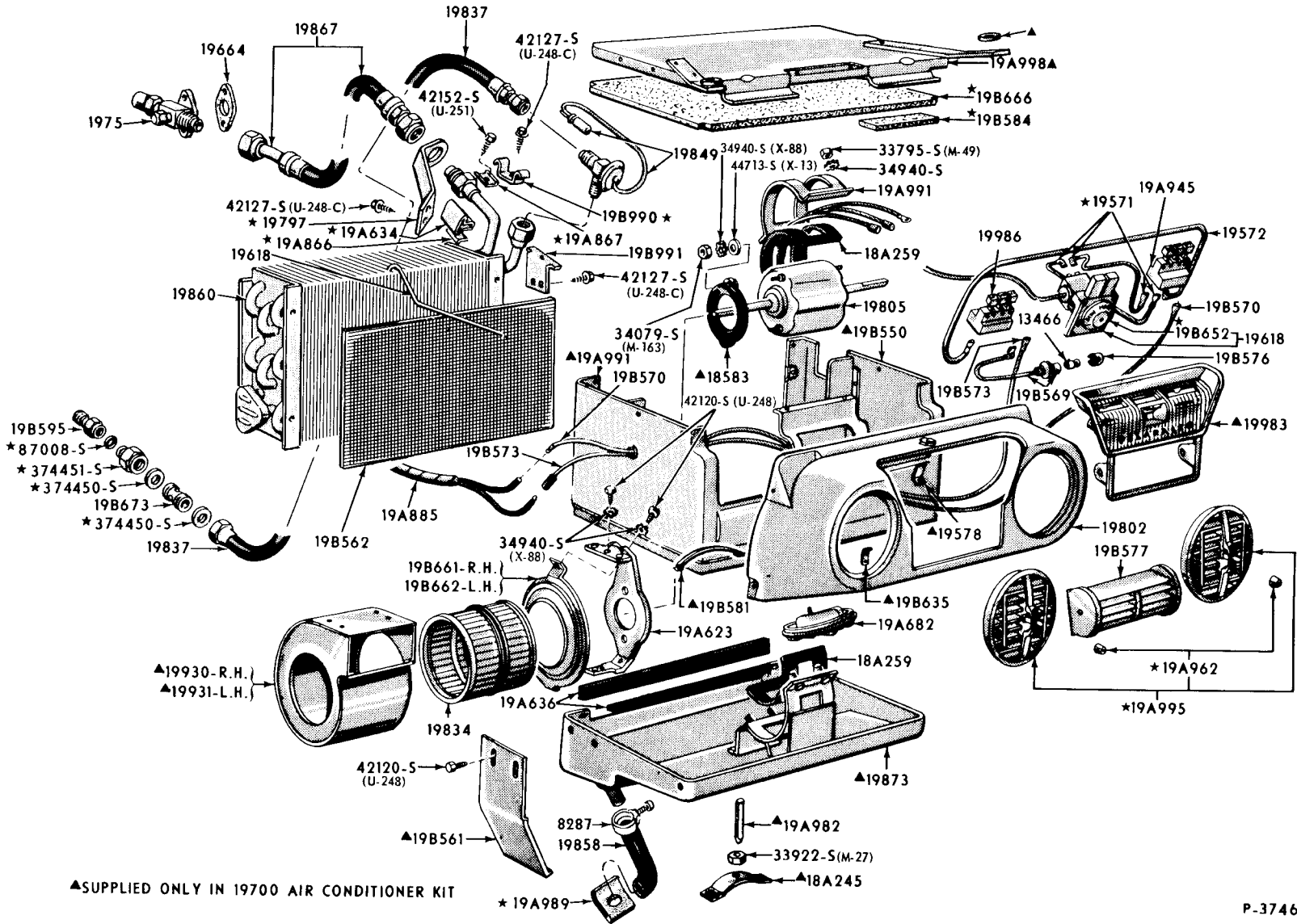

▲SUPPLIED ONLY IN 19700 AIR CONDITIONER KIT

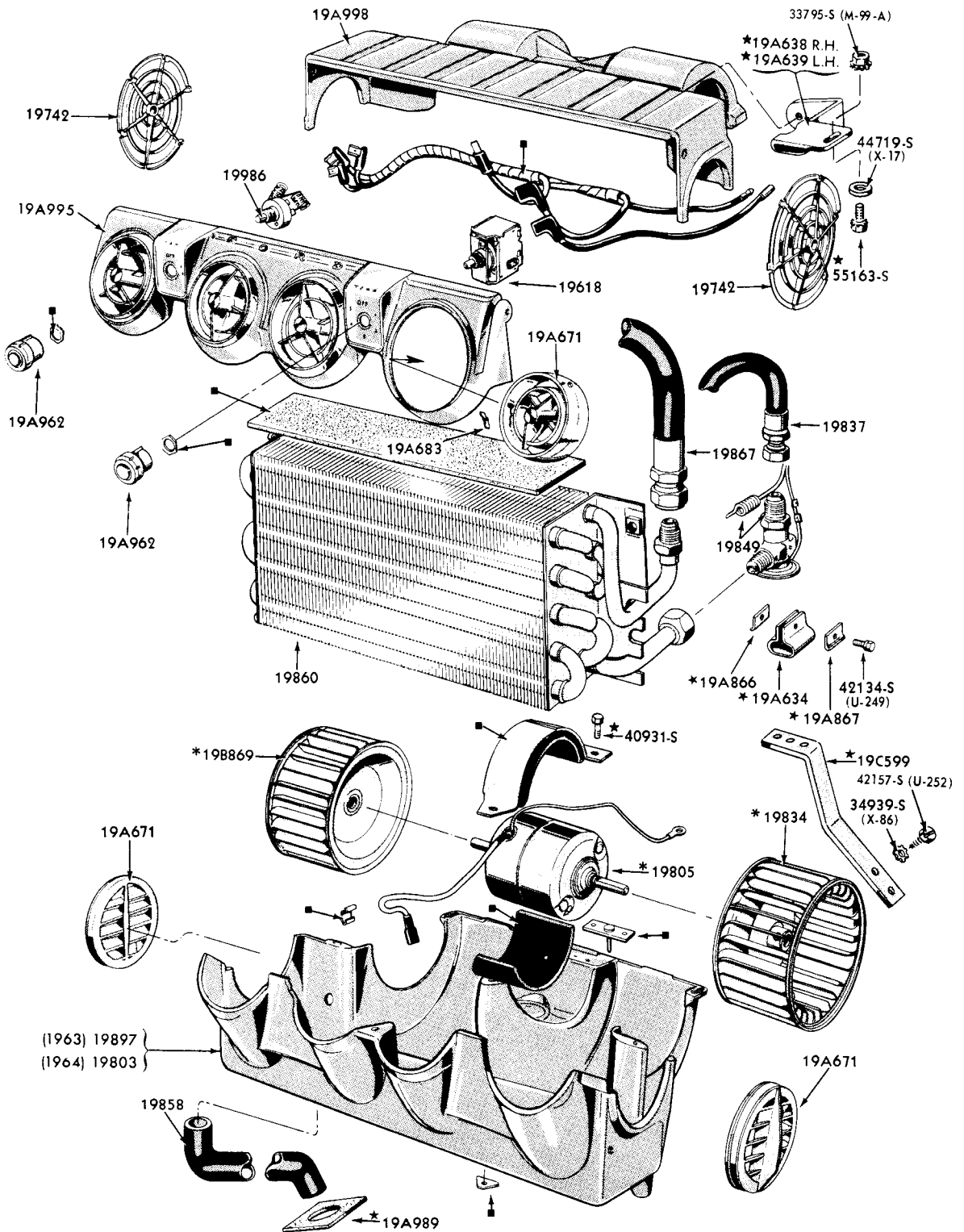

\* SUPPLIED IN 19805 MOTOR AND WHEEL ASS'Y. ONLY  
 ■ SUPPLIED IN 19700 AIR CONDITIONER KIT ONLY

1963/64 HANG-ON AIR CONDITIONER, EVAPORATOR, CONTROLS & RELATED PARTS  
 (1963/64 FORD, FAIRLANE & 1963/64 FALCON "Before 3/2/64")



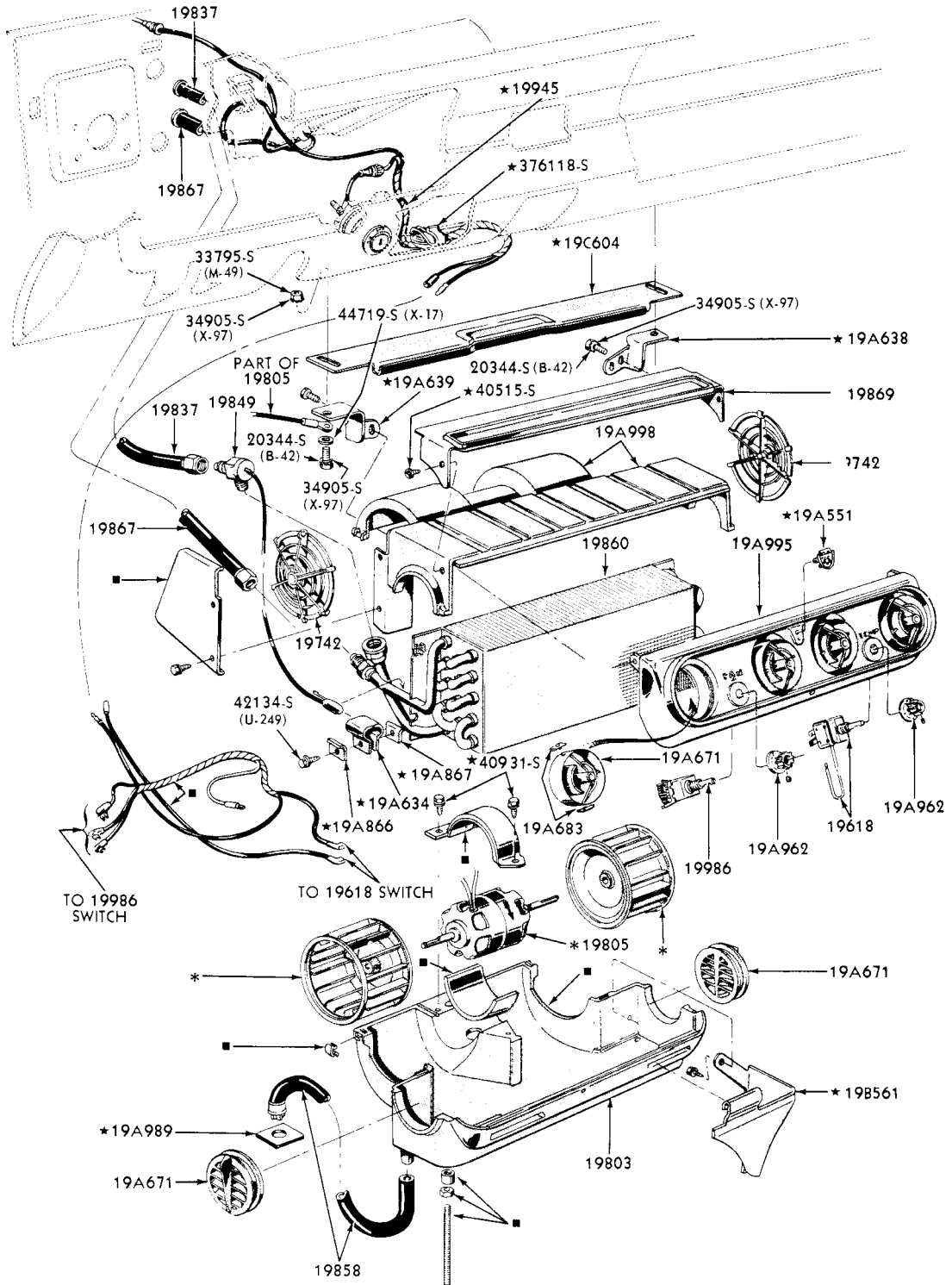

■ SUPPLIED IN 19700 AIR CONDITIONER KIT ONLY  
 \* SUPPLIED IN 19805 MOTOR AND WHEEL ASS'Y. ONLY

P-4549

1964/ HANG-ON AIR CONDITIONER EVAPORATOR, CONTROLS & RELATED PARTS  
 FALCON-"FROM 3/2/64"



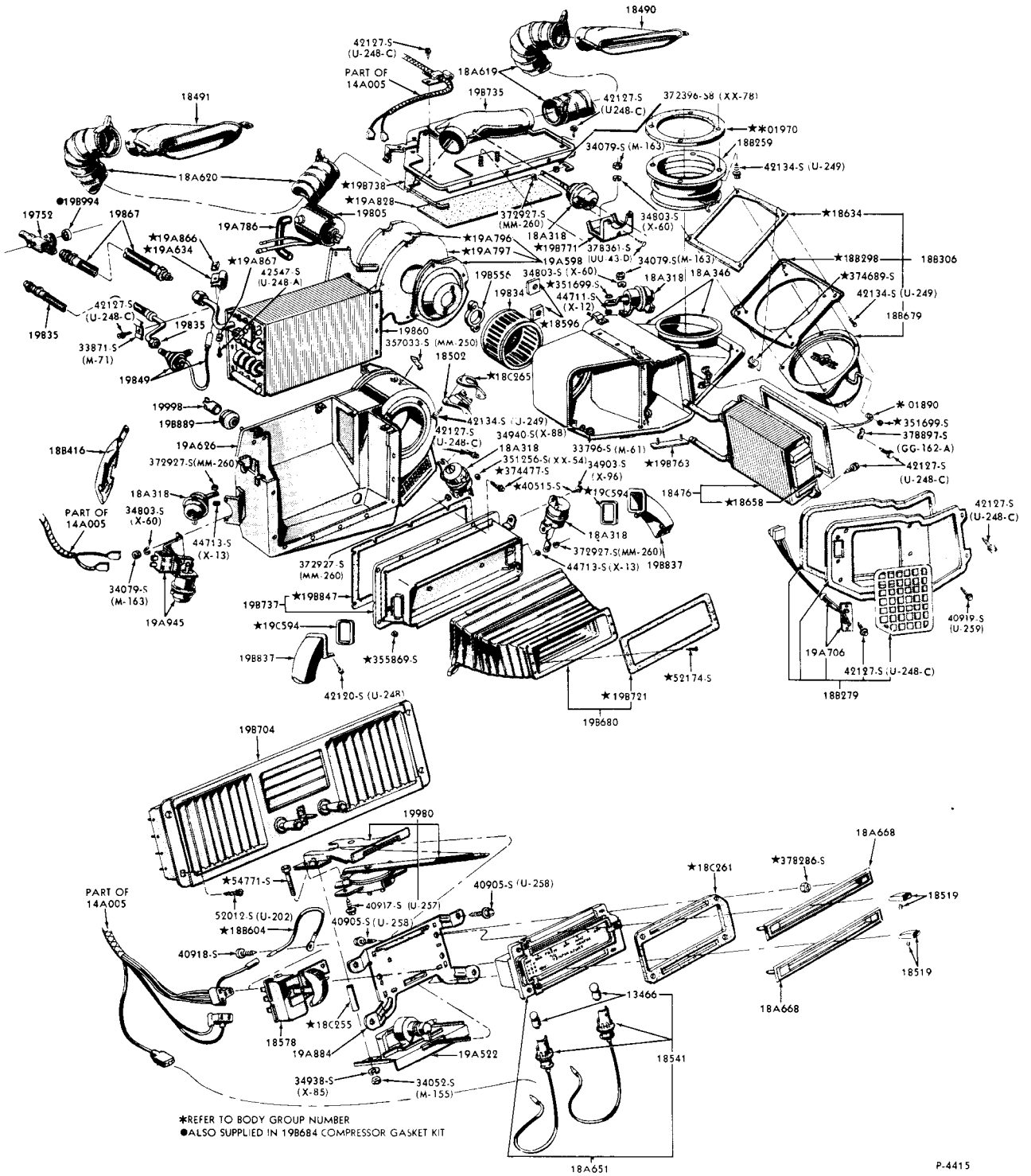

FORD CAR PARTS

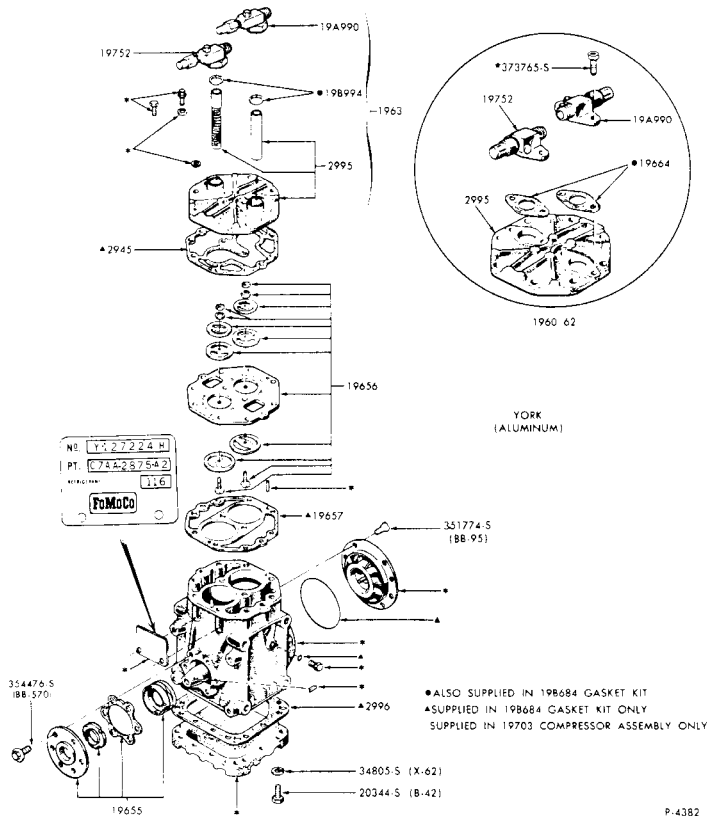

YORK DESIGN

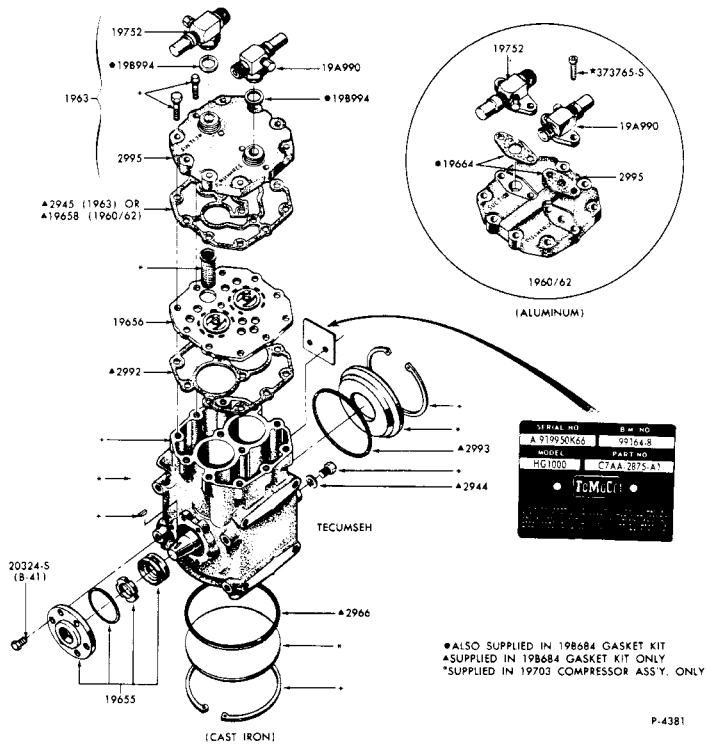

TECUMSEH DESIGN

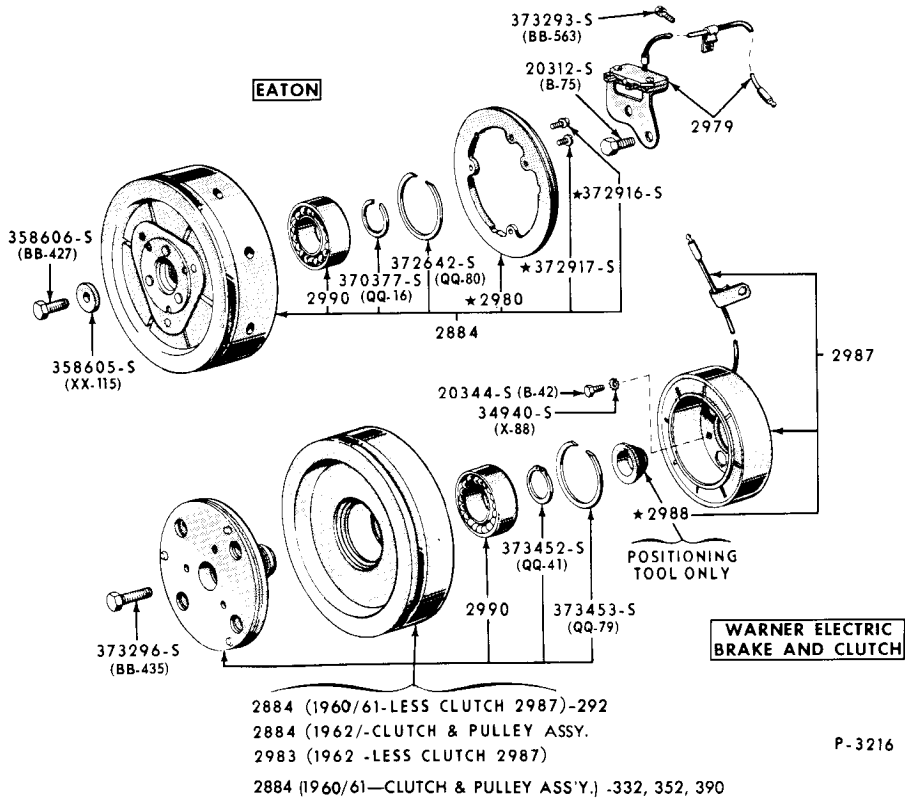

**1960/ FORD & THUNDERBIRD INTEGRAL AIR CONDITIONER COMPRESSOR CLUTCHES & RELATED PARTS**

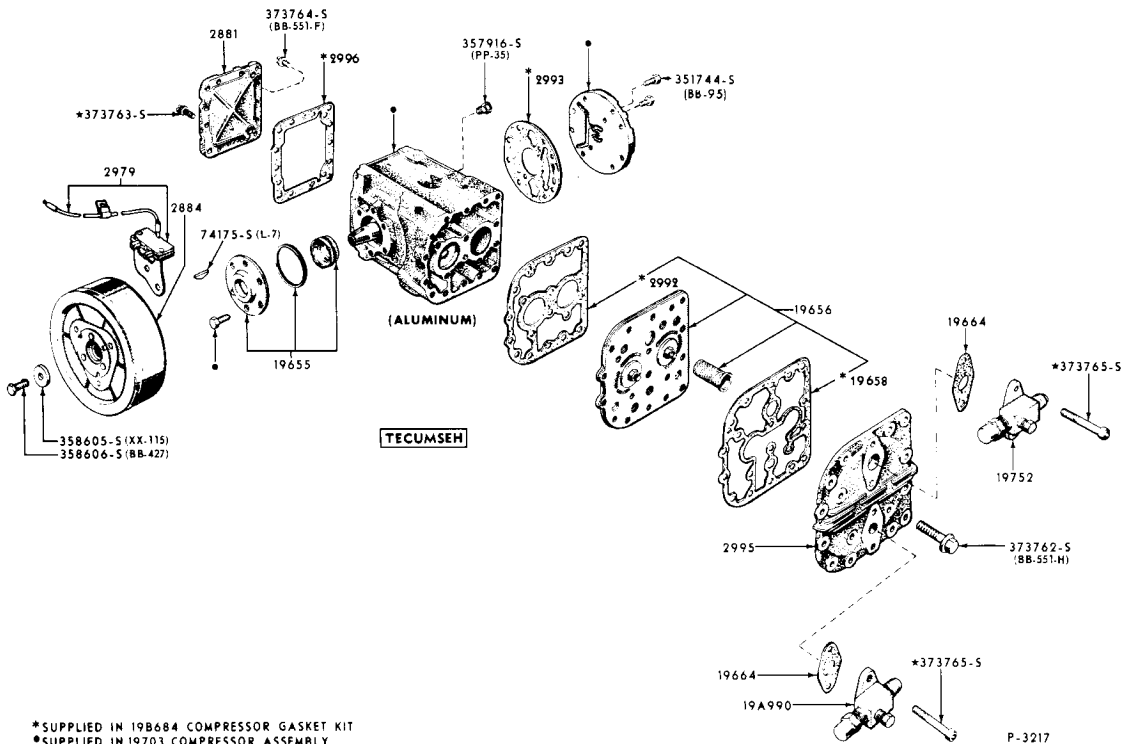

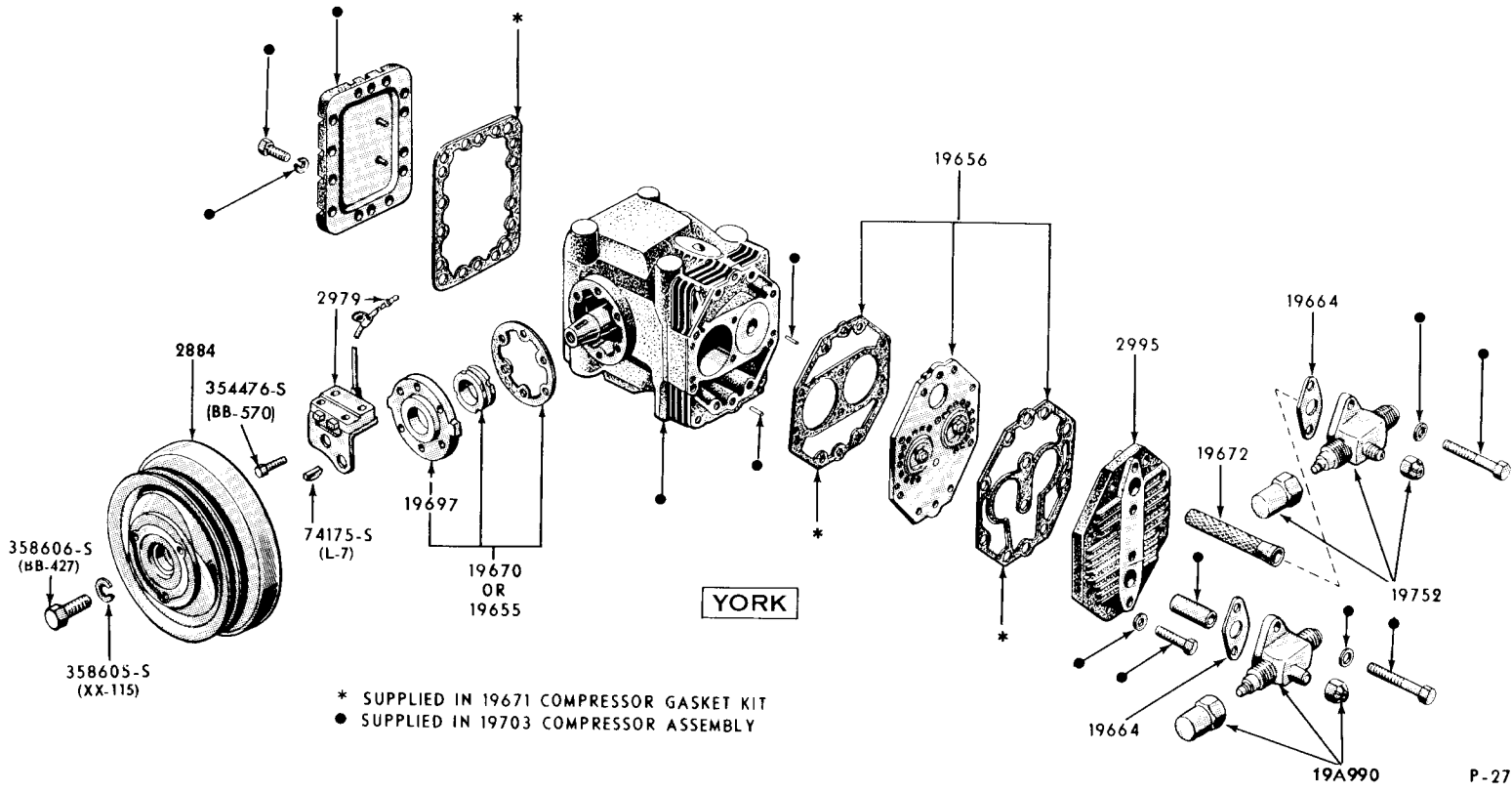

INTEGRAL AIR CONDITIONER COMPRESSOR, PULLEYS & RELATED PARTS  
(SIDE MOUNTED HOSES) 1960 THUNDERBIRD 1960 / FALCON - TYPICAL

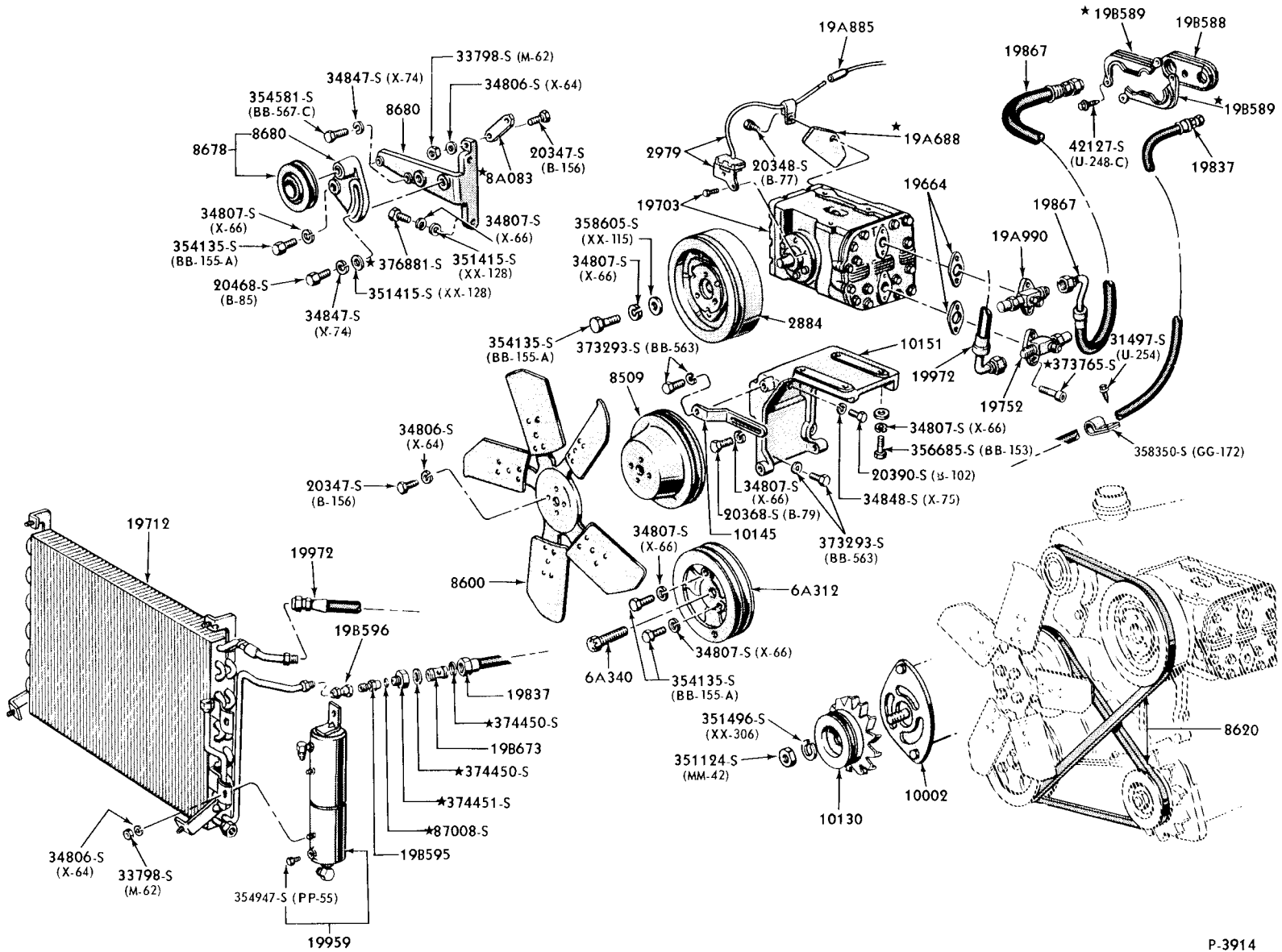

**FORD CAR PARTS**  
**ILLUSTRATION SECTION 190**

1960/62 FALCON HANG-ON AIR CONDITIONER CONDENSER, COMPRESSOR & RELATED PARTS

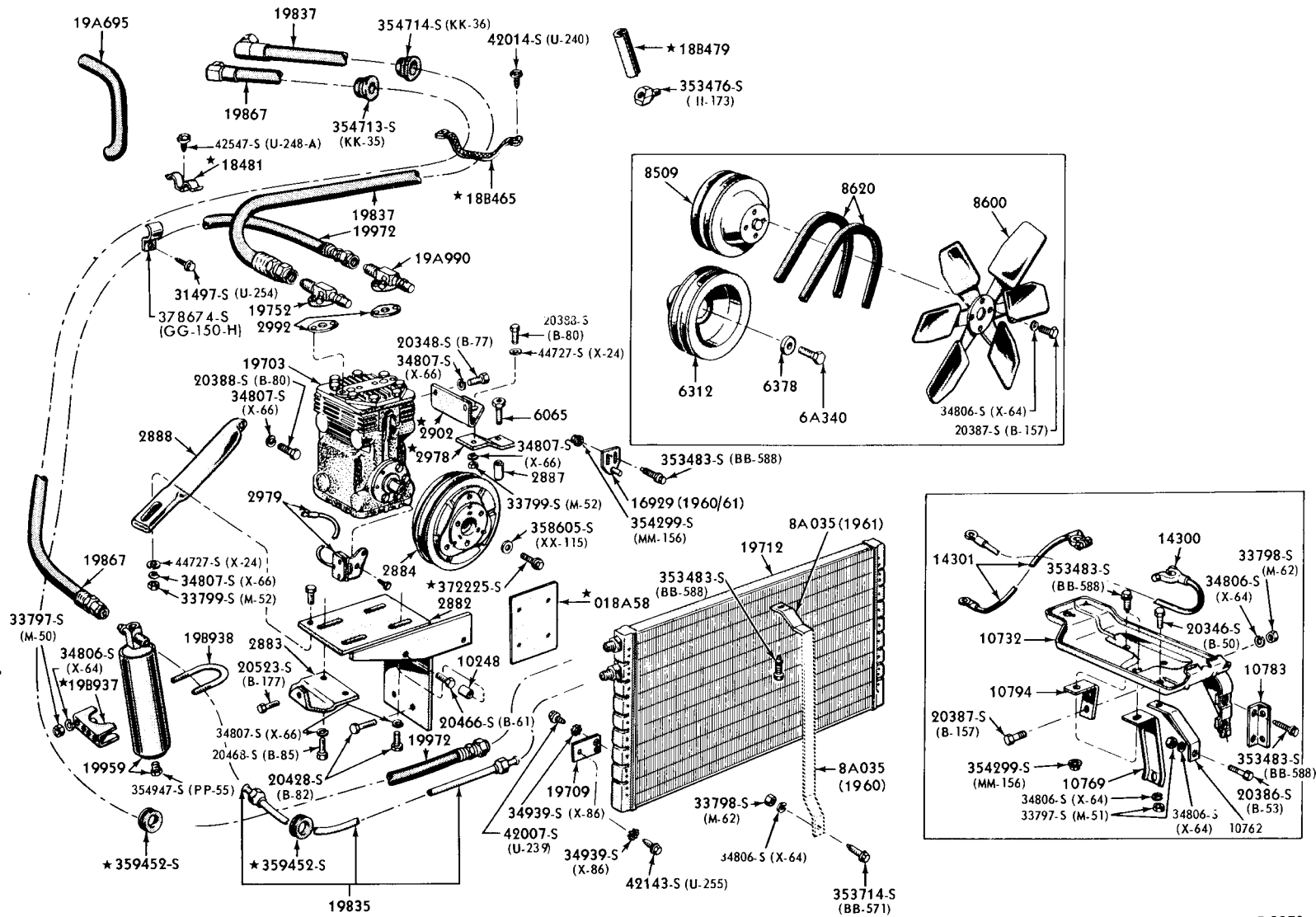



1963/64 AIR CONDITIONER CONDENSER, DEHYDRATOR, COMPRESSOR & RELATED PARTS  
(FORD - 6 CYLINDER)

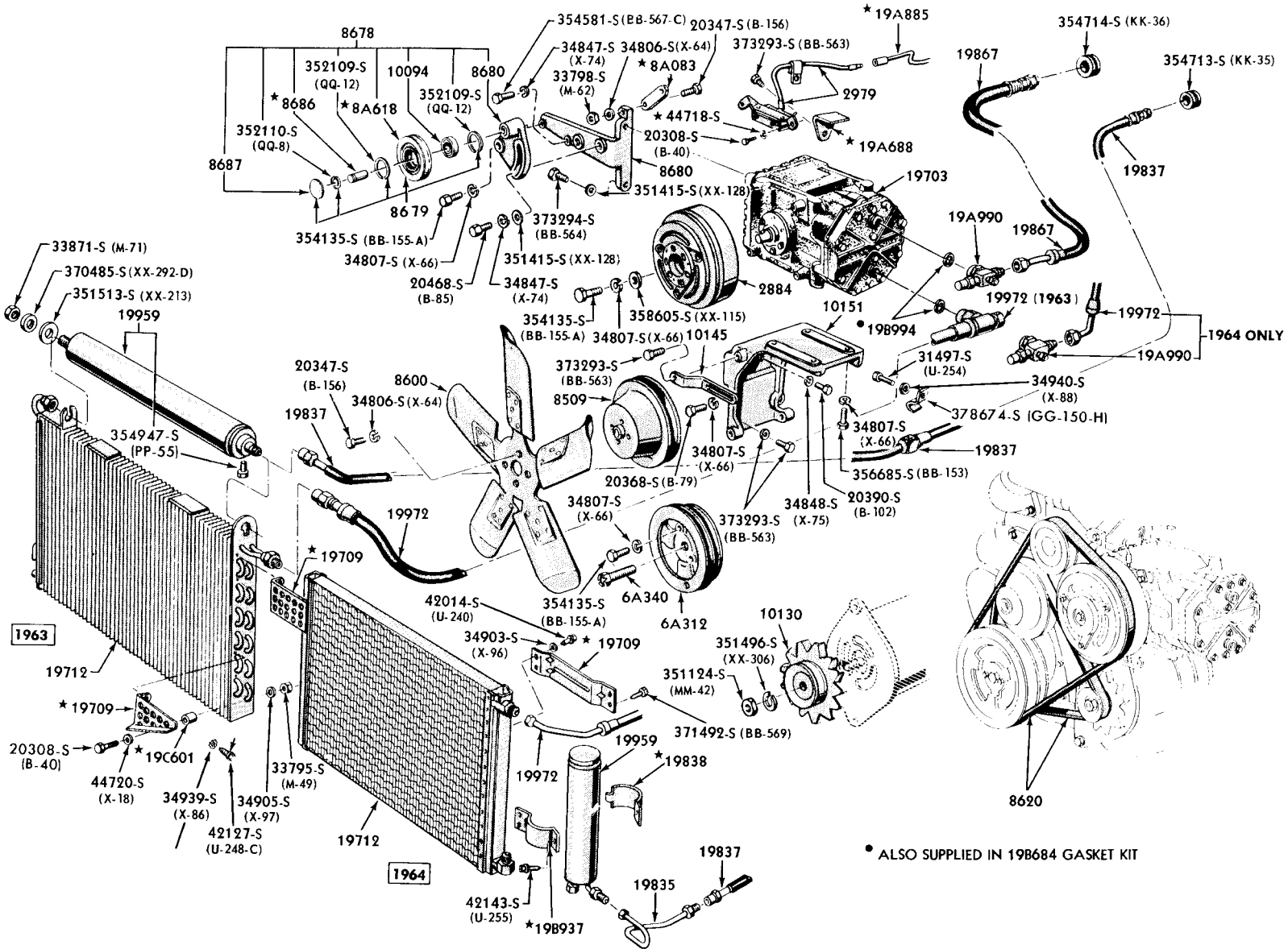

\* ALSO SUPPLIED IN 198684 GASKET KIT

FORD CAR PARTS  
ILLUSTRATION SECTION 190

1963 / HANG-ON AIR CONDITIONER CONDENSER, DEHYDRATOR, COMPRESSOR & RELATED PARTS (FALCON-6 CYLINDER)

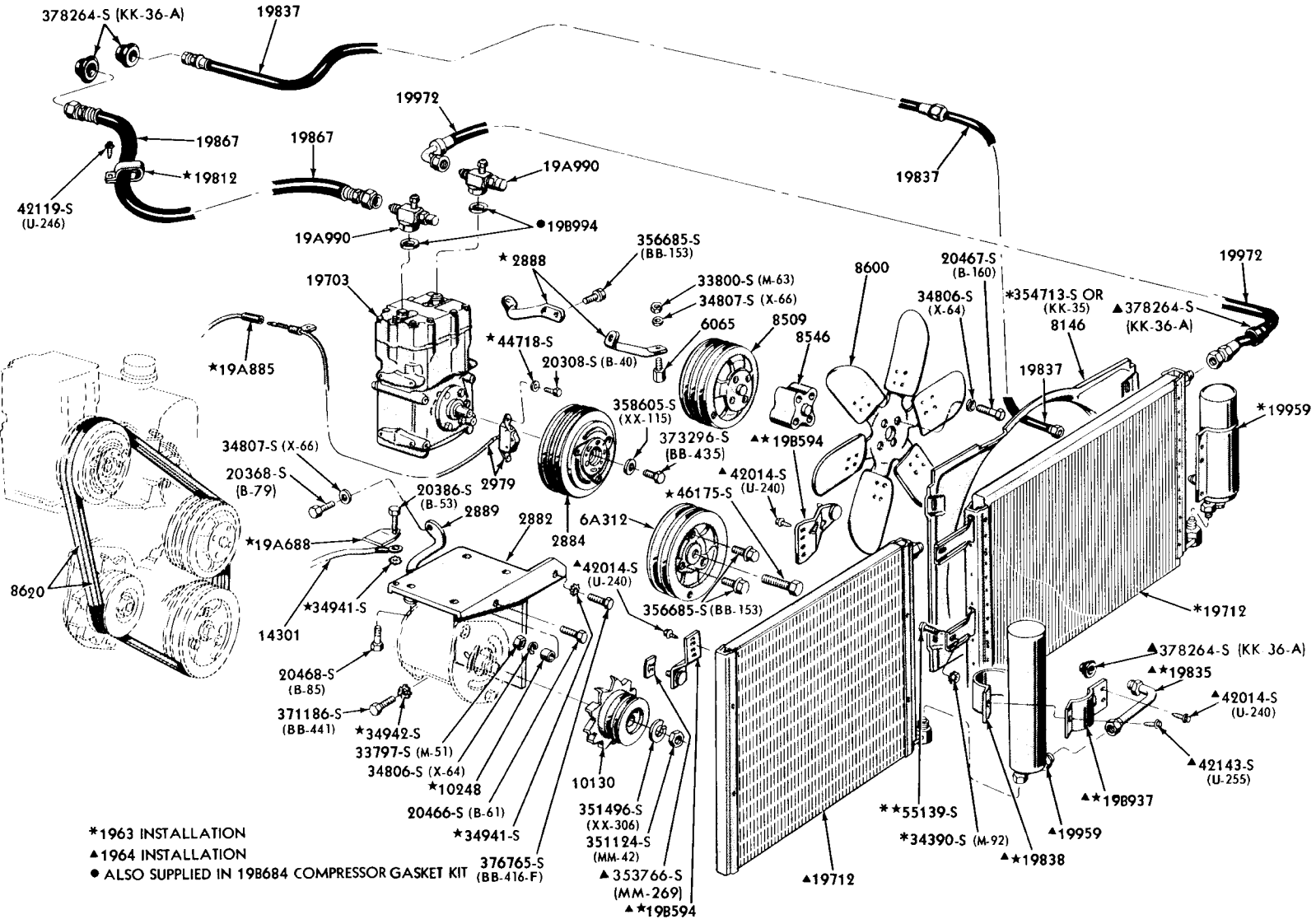

1960/61 FORD INTEGRAL & HANG-ON AIR CONDITIONER CONDENSER, DEHYDRATOR, COMPRESSOR & RELATED PARTS (8 CYLINDER)

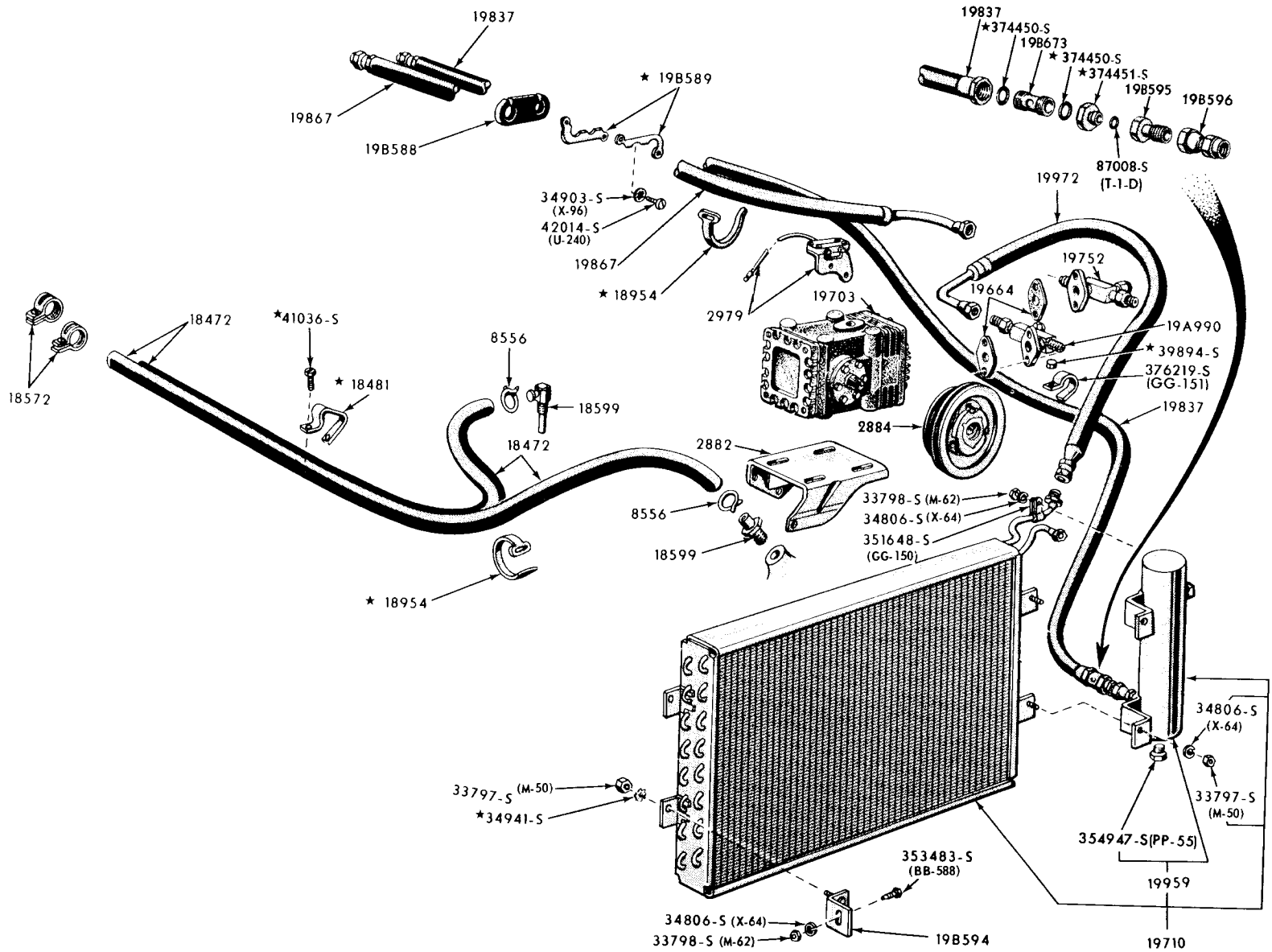

FORD CAR PARTS

ILLUSTRATION SECTION 190



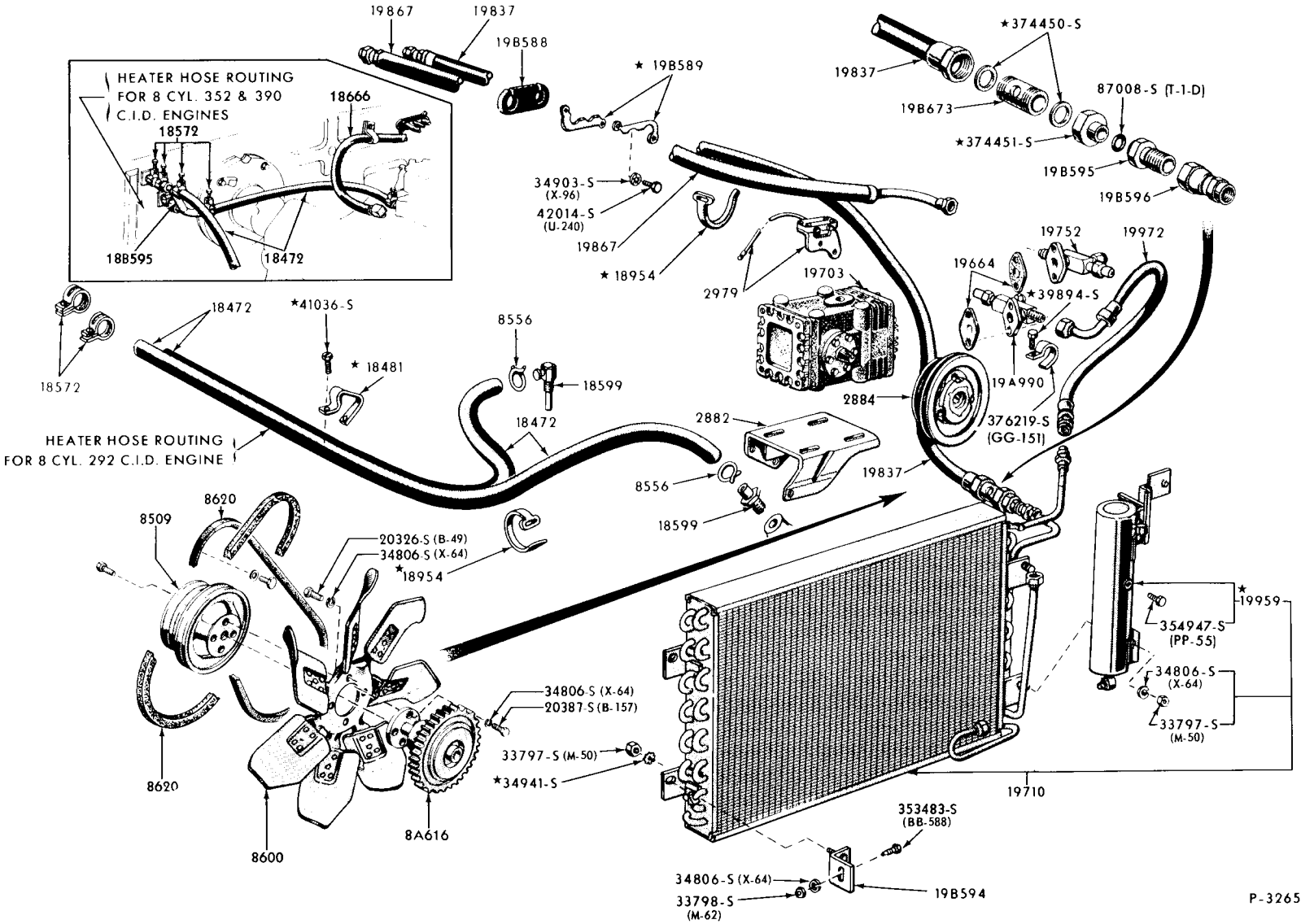

1961/62 FORD INTEGRAL & HANG-ON AIR CONDITIONER CONDENSER, DEHYDRATOR, COMPRESSOR & RELATED PARTS (8 CYLINDER)

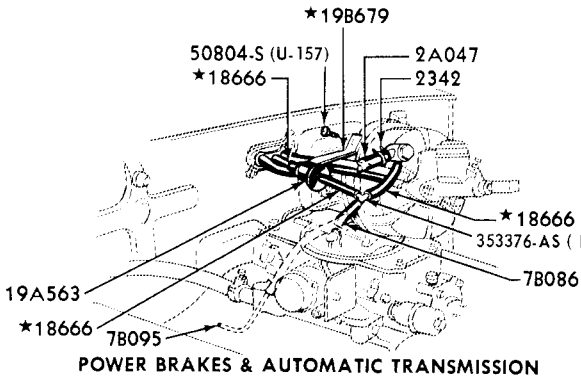

POWER BRAKES & AUTOMATIC TRANSMISSION

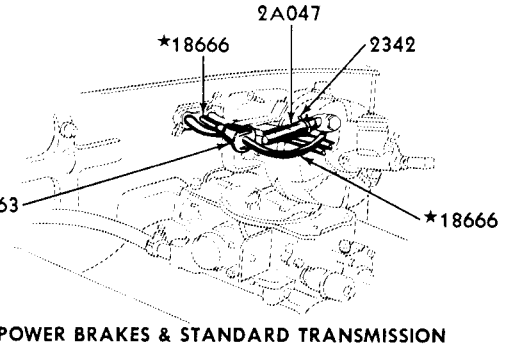

POWER BRAKES & STANDARD TRANSMISSION

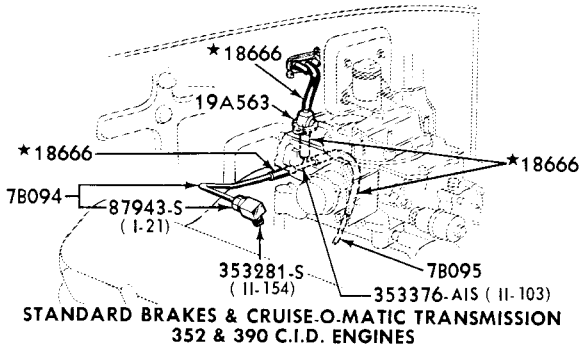

STANDARD BRAKES & CRUISE-O-MATIC TRANSMISSION 352 & 390 C.I.D. ENGINES

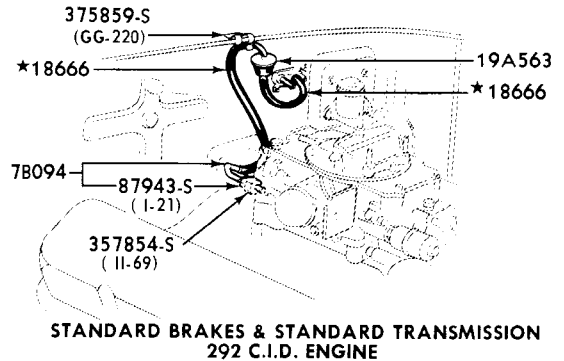

STANDARD BRAKES & STANDARD TRANSMISSION 292 C.I.D. ENGINE

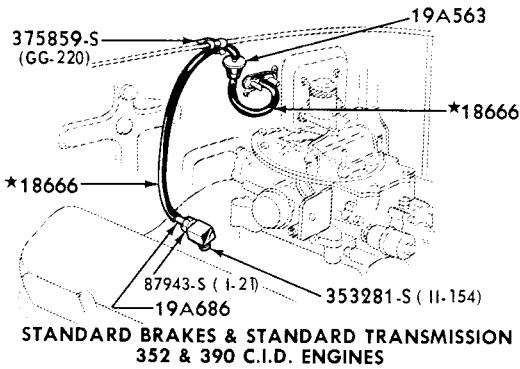

STANDARD BRAKES & STANDARD TRANSMISSION 352 & 390 C.I.D. ENGINES

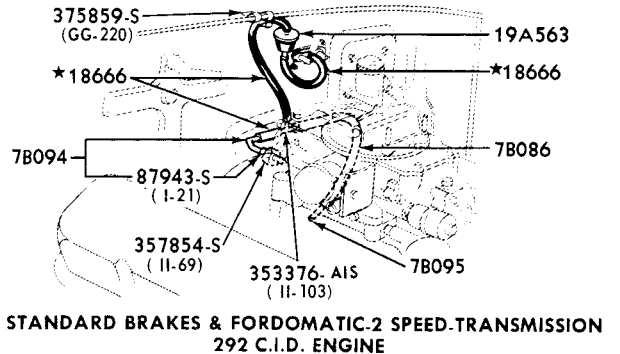

STANDARD BRAKES & FORDOMATIC-2 SPEED-TRANSMISSION 292 C.I.D. ENGINE

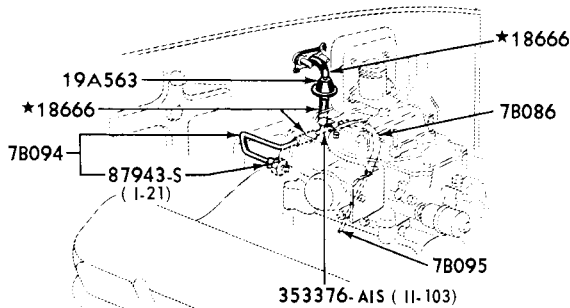

STANDARD BRAKES & CRUISE-O-MATIC TRANSMISSION 292 C.I.D. ENGINE

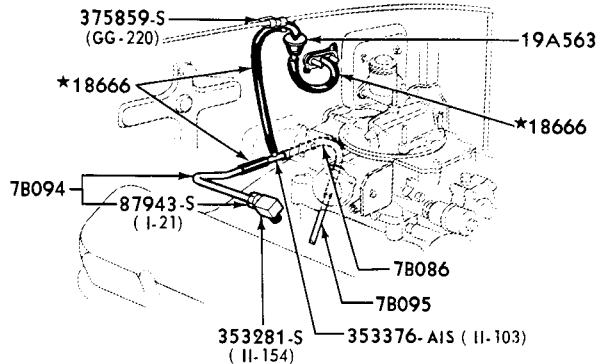

STANDARD BRAKES & FORDOMATIC-2 SPEED-TRANSMISSION 352 C.I.D. ENGINE



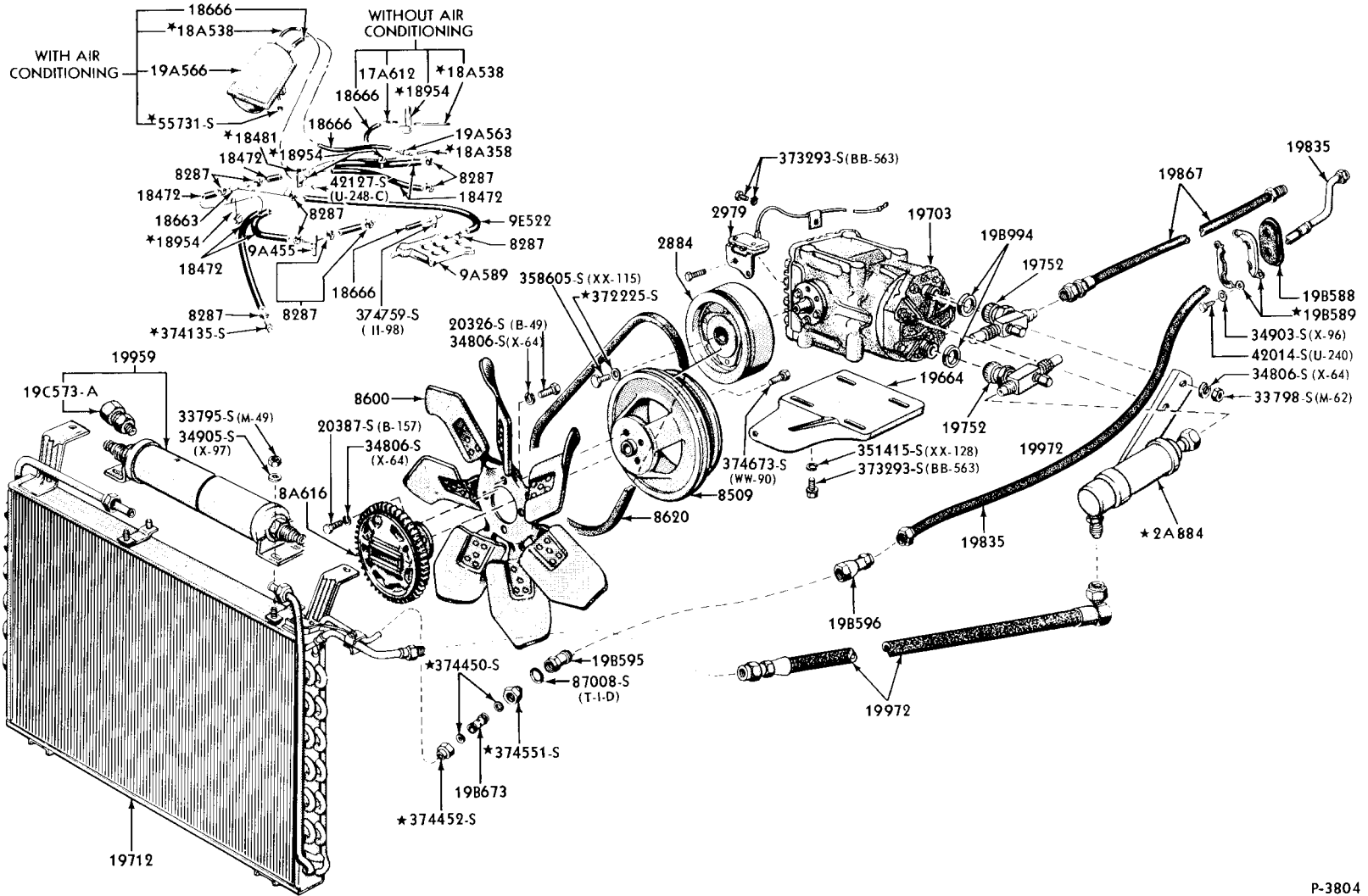

1962/63 THUNDERBIRD INTEGRAL AIR CONDITIONER CONDENSER, DEHYDRATOR, COMPRESSOR, HOSES & RELATED PARTS







**FORD CAR PARTS**

**ILLUSTRATION SECTION 190**

1963/64 INTEGRAL AIR CONDITIONER CONDENSER, DEHYDRATOR, COMPRESSOR & RELATED PARTS  
(FORD & FAIRLANE-8 CYLINDER 260 & 289)

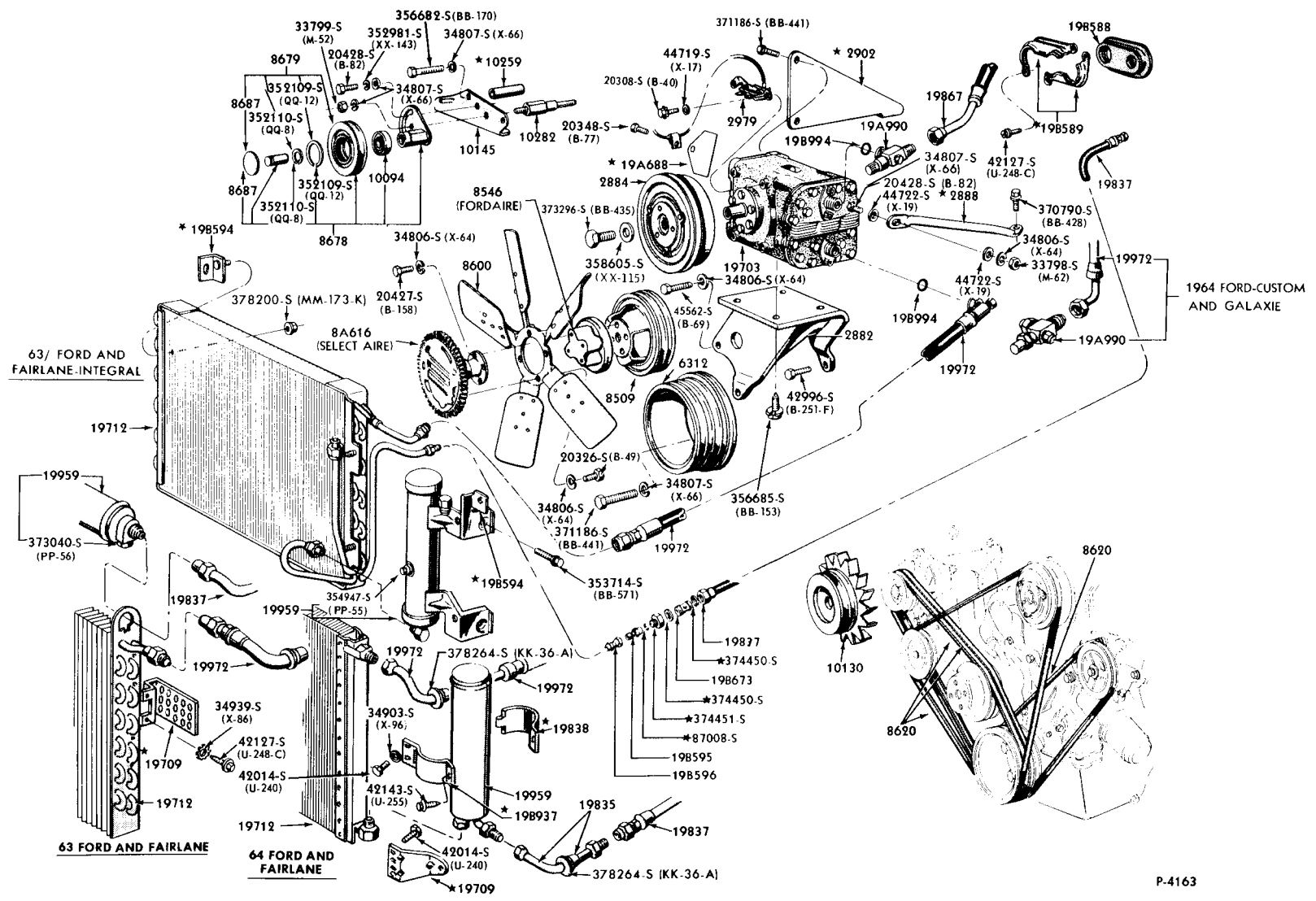

P-4163

1963 INTEGRAL AIR CONDITIONER CONDENSER, DEHYDRATOR, COMPRESSOR & RELATED PARTS (FORD-8 CYLINDER 352 & 390)

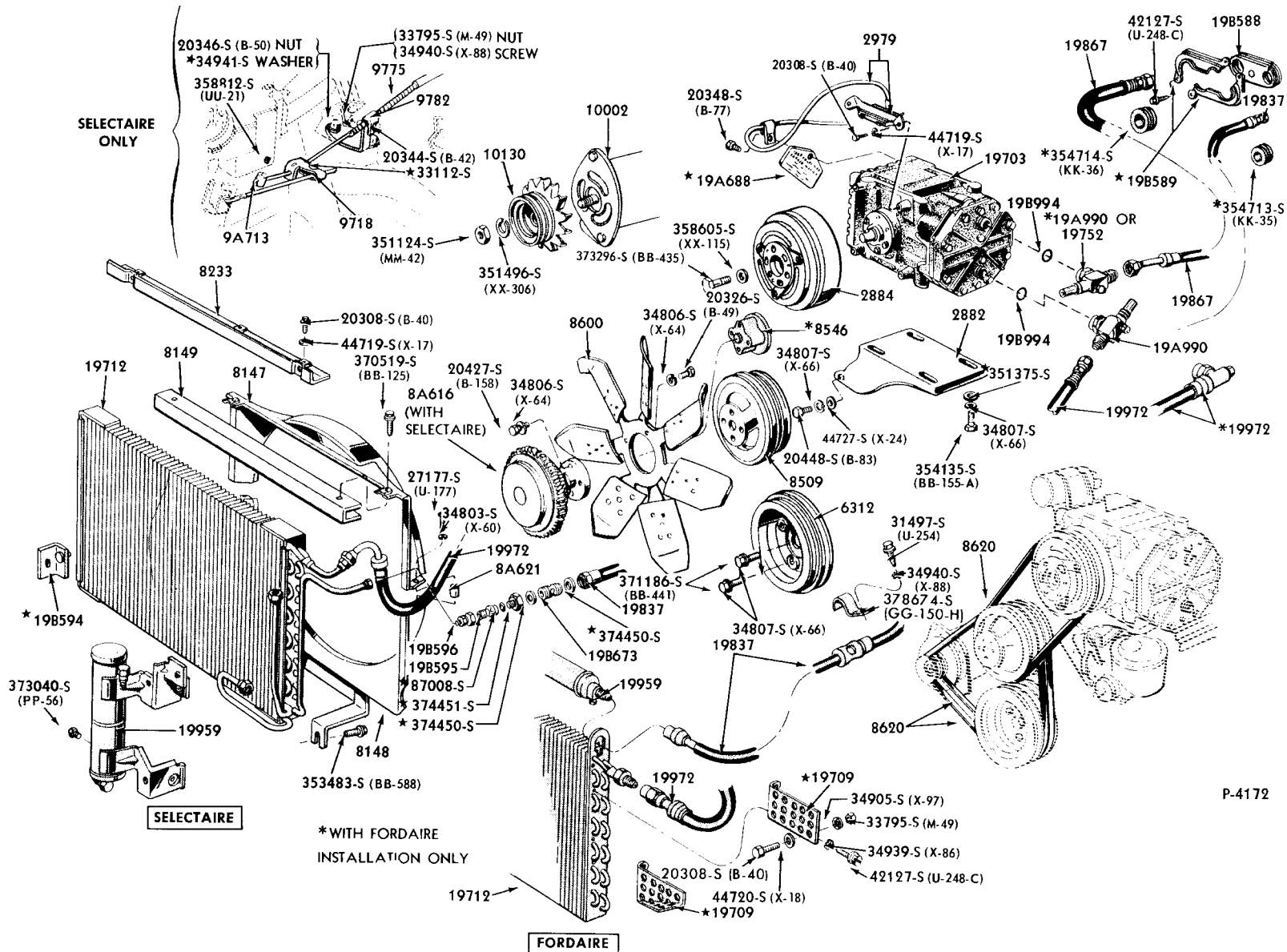

1963/ AIR CONDITIONER CONDENSER, DEHYDRATOR, COMPRESSOR & RELATED PARTS  
(FAIRLANE) - 6 CYLINDER

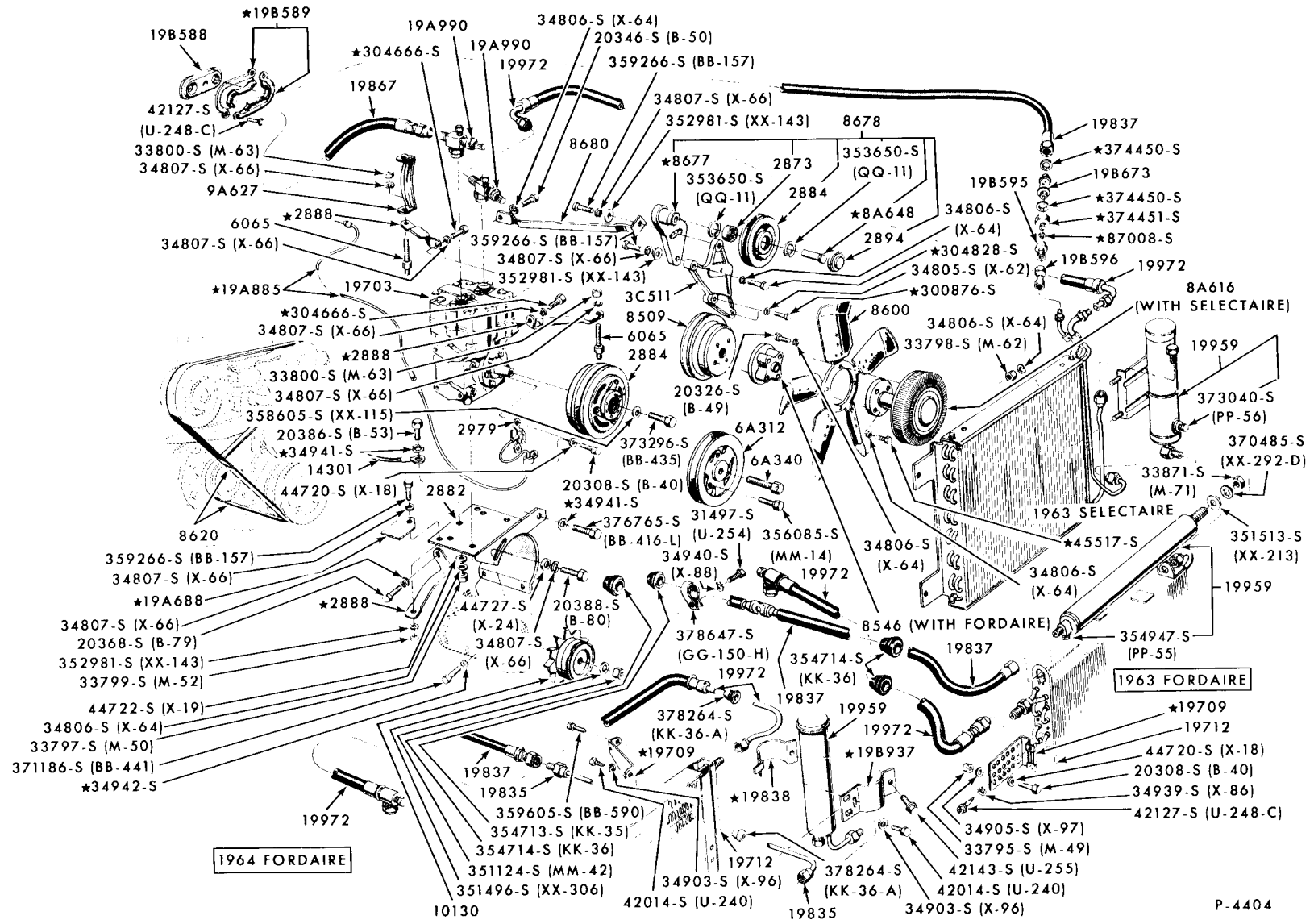

P-4404

FORD CAR PARTS  
ILLUSTRATION SECTION 190

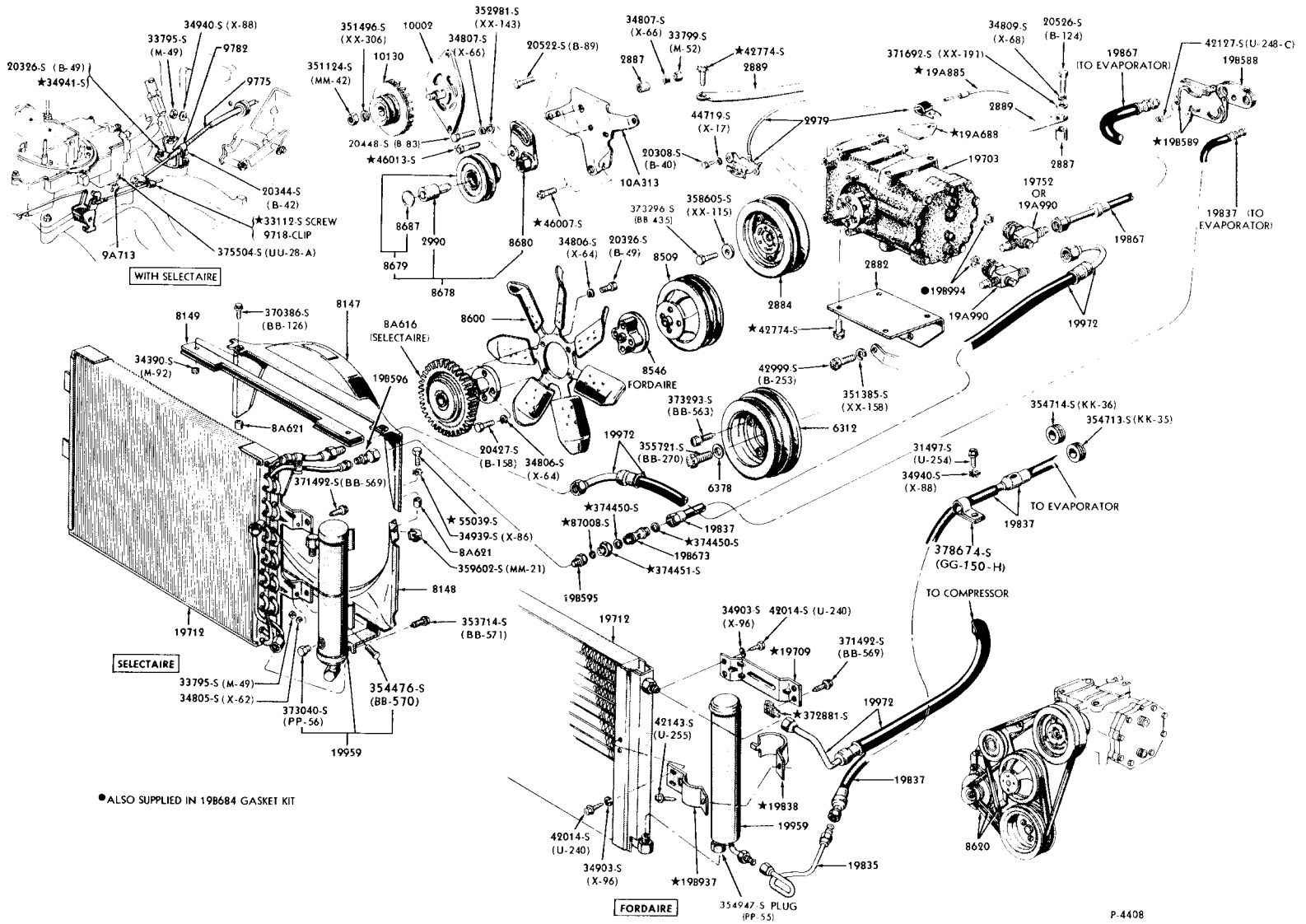

1964 AIR CONDITIONER CONDENSER, DEHYDRATOR, COMPRESSOR & RELATED PARTS (FORD-8 CYLINDER 352 & 390)



